

PART 2

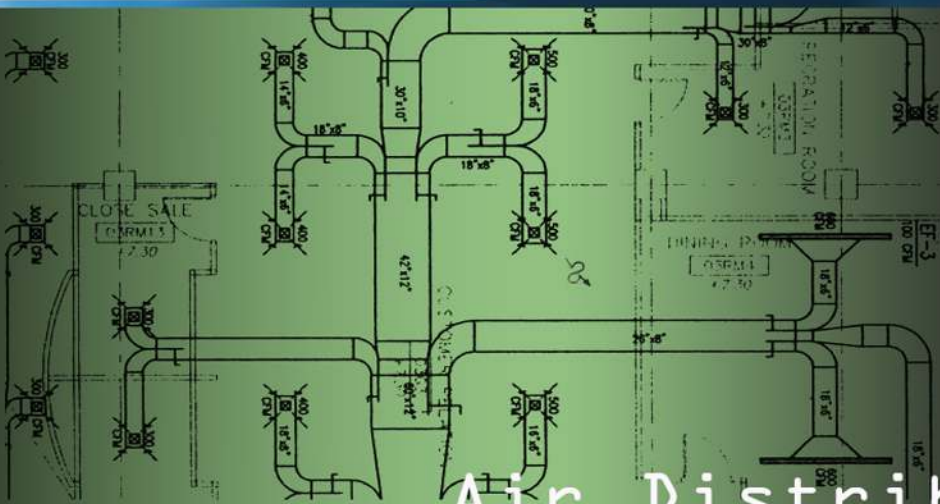

Air Distribution





CONTENTS

PART **2** AIR DISTRIBUTION

SYSTEM DESIGN MANUAL

SUMMARY OF PART TWO

This part of the System Design Manual presents data and examples to the engineer in practical design and layout of air handling equipment, ductwork and air distribution components.

The text of this manual is offered as a general guide for the use of industry and of consulting engineers in designing systems. Judgment is required for application to specific installation, and Carrier is not responsible for any uses made of this text.

air handling apparatus

1

air duct design

2

room air distribution

3

INDEX

CHAPTER 1. AIR HANDLING APPARATUS

This chapter describes the location and layout of air handling apparatus from the outdoor air intake thru the fan discharge on a standard air conditioning system. Construction details are also included for convenience.

Air handling apparatus can be of three types: (1) built-up apparatus where the casing for the conditioning equipment is fabricated and installed at or near the job site; (2) fan coil equipment that is manufactured and shipped to the job site, either completely or partially assembled; and (3) self-contained equipment which is shipped to the job site completely assembled.

This chapter is primarily concerned with built-up apparatus; fan coil and self-contained equipment are discussed in Part 6. In addition to the built-up apparatus, items such as outdoor air louvers, dampers, and fan discharge connections are also discussed in the chapter. These items are applied to all types of apparatus.

Equipment location and equipment layout must be carefully studied when designing air handling apparatus. Thus two items are discussed in detail in the following pages.

LOCATION

The location of the air handling apparatus directly influence the economic and sound level aspects of any system.

ECONOMIC CONSIDERATION

The air handling apparatus should be centrally located to obtain a minimum-first-cost system. In a few instances, however, it may be necessary to locate the apparatus, refrigeration machine, and cooling tower in one area, to achieve optimum system cost. When the three components are grouped in one location, the cost of extra ductwork is offset by the reduced piping cost. In addition, when the complete system becomes large enough to require more than one refrigeration machine, grouping the mechanical equipment on more than one floor becomes practical. This design is often used in large buildings. The upper floor equipment handles approximately the top 20 to 30 floors, and the lower floor equipment is used for the lower 20 to 30 floors.

Occasionally a system is designed requiring a grouping of several units in one location, and the use of single unit in a remote location. This condition should be

carefully studied to obtain the optimum coil selection-versus-piping cost for the remotely located unit. Often, the cost of extra coil surface is more than offset by the lower pipe cost for the smaller water quantity resulting when the extra surface coil is used.

SOUND LEVEL CONSIDERATIONS

It is extremely important to locate the air handling apparatus in areas where reasonable sound levels can be tolerated. Locating apparatus in the conditioned space or adjacent to areas such as conference rooms, sleeping quarters and broadcasting studios is not recommended. The following items point up the conditions that are usually created by improper location; these conditions can be eliminated by careful planning when making the initial placement of equipment:

1. The cost of correcting a sound or vibration problem after installation is much more than the original cost of preventing it.
2. It may be impossible to completely correct the sound level, once the job is installed.
3. The owner may not be convinced even after the trouble has been corrected.

The following practices are recommended to help avoid sound problems for equipment rooms located on upper floors.

1. In new construction, locate the steel floor framing to match equipment supports designed for weights, reactions and speeds to be used. This transfers the loads to the building columns.
2. In existing buildings, use of existing floor slabs should be avoided. Floor deflection can, at times, magnify vibration in the building structure. Supplemental steel framing is often necessary to avoid this problem.
3. Equipment rooms adjacent to occupied spaces should be acoustically treated.
4. In apartments, hotels, hospitals and similar buildings, non-bearing partition walls should be separated at the floor and ceilings adjoining occupied spaces by resilient materials to avoid transmission of noise vibration.
5. Bearing walls adjacent to equipment rooms should be acoustically treated on the occupied side of the wall.

LAYOUT

Package equipment is usually factory shipped with all of the major equipment elements in one unit. With this arrangement, the installation can be completed by merely connecting the ductwork and assembling and installing the accessories.

In a central station system, however, a complete, workable and pleasing layout must be made of all major components. This involves considerations usually not present in the unitary equipment installation.

The shape and cross-sectional area of the air handling equipment are the factors that determine the dimensions of the layout. The dehumidifier assembly or the air cleaning

equipment usually dictates the overall shape and dimensions. A superior air handling system design has a regular shape. A typical apparatus is shown in Fig 1. The shape shown allows for a saving in sheet metal fabrication time and, therefore, is considered to be better industrial appearance. From a functional standpoint, an irregular shaped casing tends to cause air stratification and irregular flow patterns.

The most important rule in locating the equipment for the air handling apparatus is to arrange the equipment along a center line for the best air flow conditions. This arrangement keeps plenum pressure losses to a minimum, and is illustrated in Fig 1.

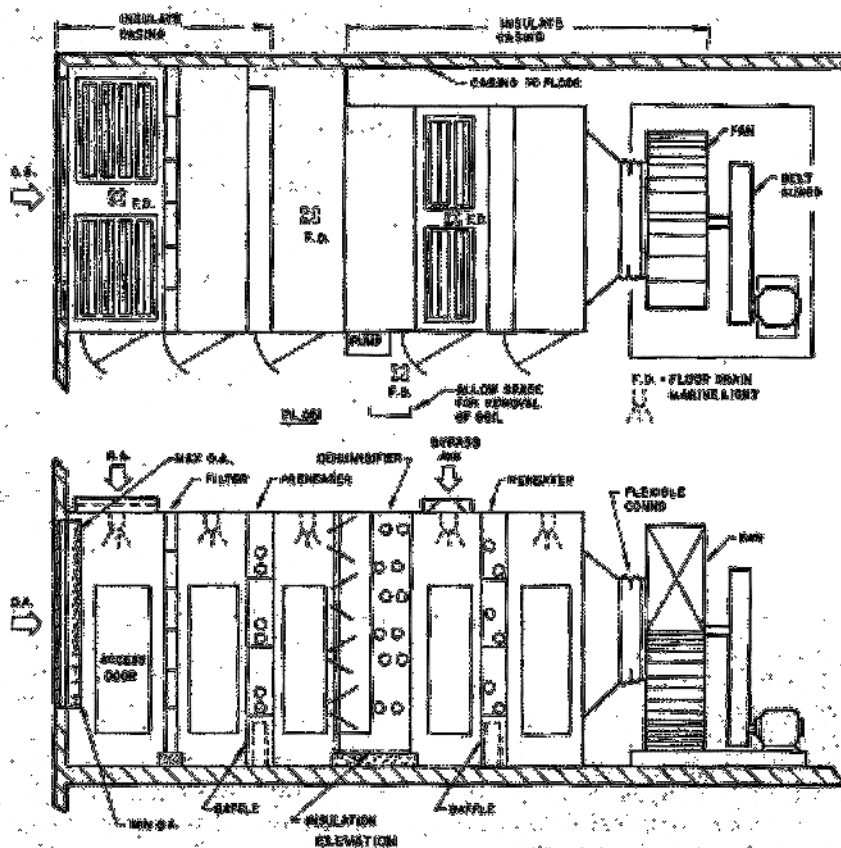

Fig. 1 – Typical Central Station Equipment

EQUIPMENT

This section describes available central station apparatus equipment and recommends suitable application of the various components.

OUTDOOR AIR LOUVERS AND SCREEN

Fig 2. Illustrates outdoor air louvers that minimize the entry of snow and water into the equipment. It is impossible to completely eliminate all moisture with vertical louvers, and this is usually not necessary. The screen is added to arrest most foreign materials such as

paper, trash and birds. Often the type of screen required and the mesh are specified by codes.

The screen and louver is located sufficiently above the roof to minimize the pickup of roof dust and the probability of snow piling up and subsequently entering the louver during winter operation. This height is determined by the annual snowfall. However, a minimum of 2.5 feet is recommended for most areas. In some locations, doors are added outside the louver for closure during extreme in element weather such as hurricanes and blizzards.

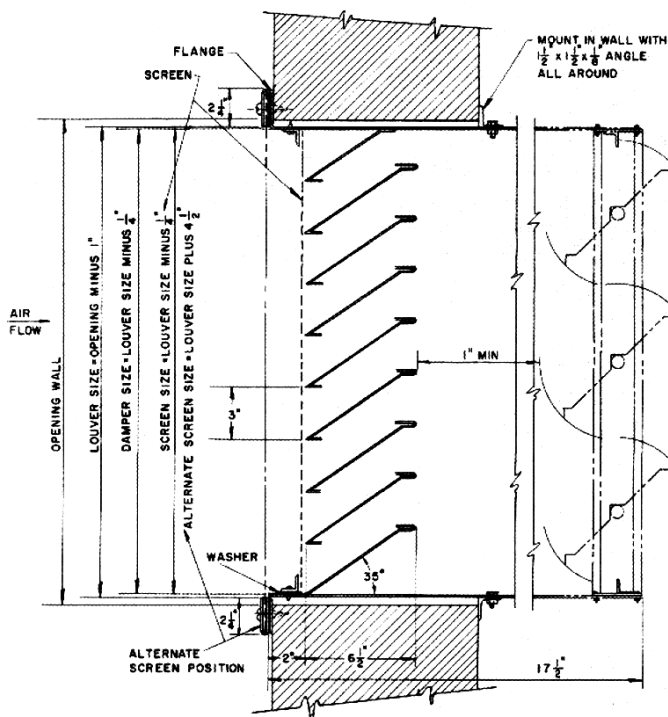

MATERIAL SPECIFICATIONS

Maximum Over-all Height	91 1/2"
Maximum Over-all Width	95"
Blades	22 U.S. gage steel*
Frame	18 U.S. gage steel*
Screen	1/2" #16 wire mesh
Screen Frame	1" x 1" x 1/8" angle
Braces	1" x 1/8" band iron
*Equivalent strength aluminum may be substituted.	

SCREEN AND BRACES

LOUVER WIDTH (in.)	NUMBER OF SCREENS†	NUMBER OF BRACES‡
0 - 30	1	0
31 - 47	1	1
48 - 60	2	1
61 - 95	2	2
Over 95	2 equal length louvers	

†Screens over 60" high have center horizontal stiffening braces of 1" x 1" x 1/8" angle.

‡Braces spaced evenly on front and back of louver and tack welded to blade edges.

Fig. 2 – Outdoor Air Louver and Screen

It is best to locate the outdoor air louver in such a manner that cross contamination from exhaust fan to louver does not occur, specifically toilet and kitchen exhaust. In addition, the outdoor air intake is located to minimize pulling air over a long stretch of roof since this increases the outdoor air load during summer operation.

Chart 1 is used to estimate the air pressure loss at various face velocities when the outdoor louvers are constructed, as shown in Fig 2.

There are occasions when outdoor air must be drawn into the apparatus thru the roof. One convenient method of accomplishing this is shown in Fig 3. The gooseneck arrangement shown in this figure is also useful for exhaust systems.

LOUVER DAMPERS

The louver damper is used for three important functions in the air handling apparatus: (1) to control and mix outdoor and return air; (2) to bypass heat transfer equipment; and (3) to control air quantities handled by the fan.

Fig. 4 shows two damper blade arrangements. The single action damper is used in locations where the damper is either fully open or fully closed. A double-acting damper is used where control of air flow is required. This arrangement is superior since the air flow is throttled more or less in proportion to the blade position, whereas the single action type damper tends to divert the air and does little or no throttling until the blades are nearly closed.

Outdoor and return air dampers are located so that good mixing of the two air streams occurs. On installations that operate 24 hours a day and are located in a mild climate, the outdoor damper is occasionally omitted.

With the fan operating and the damper fully closed, leakage cannot be completely eliminated. Chart 2 is used to approximate the leakage that occurs, based on an anticipated pressure difference across the closed damper.

Table 1 gives recommendations for various louver dampers according to function, application, velocities and type of action required.

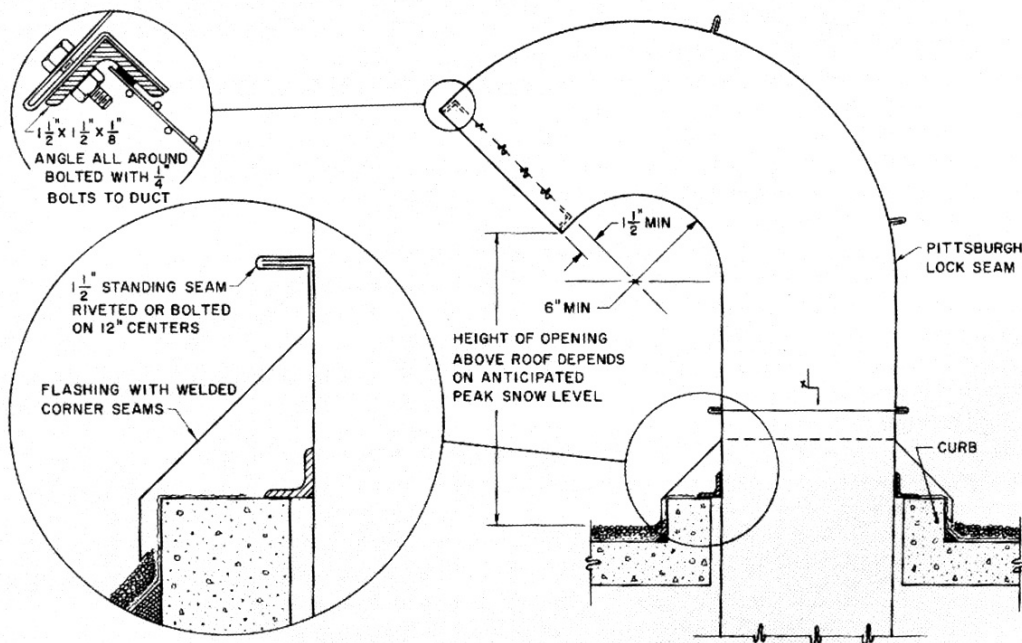

NOTE: Supplemental wind bracing may be required on larger intakes.

Fig. 3 – Gooseneck Outside Air Intake

CHART 1 – LOUVER PRESSURE DROP

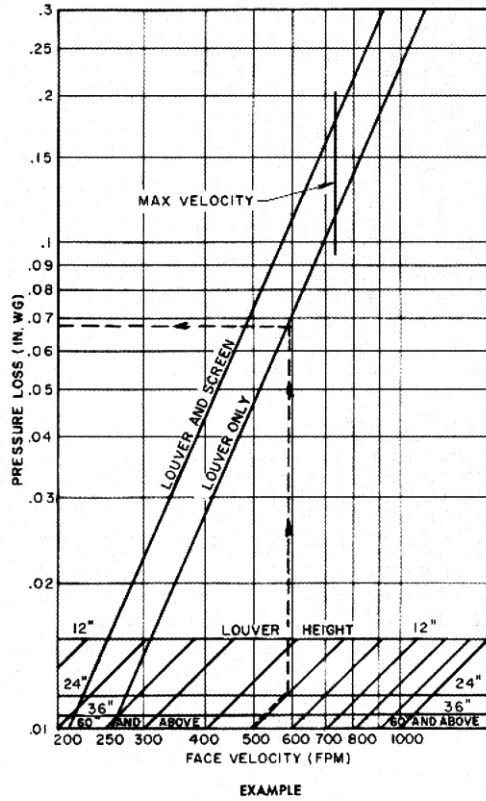

EXAMPLE
 Given: 24" high stationary louver with 500 fpm face velocity. No screen.
 Find: Pressure loss
 Solution: Pressure loss = .067 in. wg

CHART 2 – LOUVER DAMPER LEAKAGE

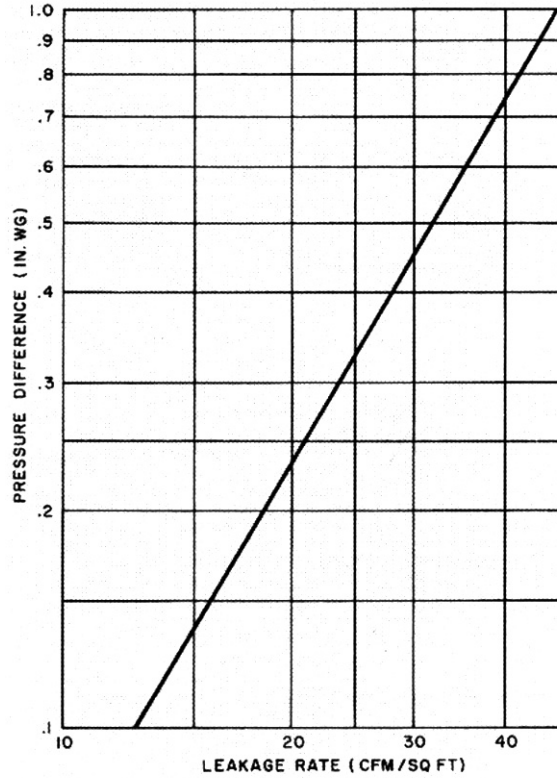
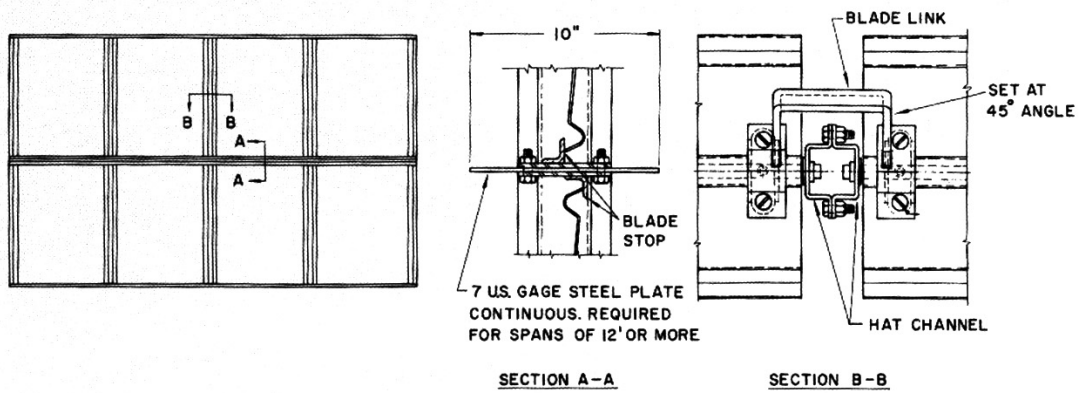
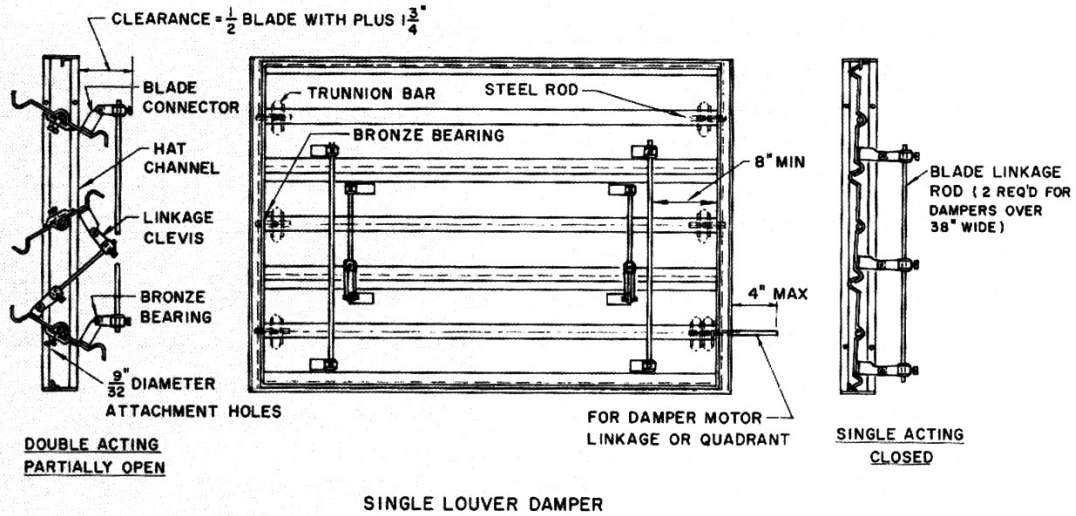

TABLE 1 – LOUVER DAMPERS

FUNCTION OR LOCATION	APPLICATION	VELOCITY* (fpm)	REMARKS
Minimum Outdoor Air	Ventilation	500-800	The higher limit may be used with short outdoor air duct connection and long return air duct. May be single acting damper.
Maximum Outdoor Air	Permissible system resistance and balance	500-800	Should be double acting when used for throttling.
All Outdoor Air	Permissible system resistance and balance	500-800	Single acting damper may be used.
Return Air	Permissible system resistance and balance	800-1200	May be higher velocity with short return duct and long outdoor air duct. Should be double acting damper.
Dehumidifier Face	Control space conditions	400-800	Should equal cross-sectional area of dehumidifier. Should be a double acting damper.
Dehumidifier Bypass	System balance	1500-2500	Should balance resistance of dehumidifier plus humidifier face damper. Should be double acting.
Heater Bypass	Balance	1000-1500	Should balance resistance at heater. Should be double acting.
Fan Section or Discharge or Located in Duct	Available duct area	same as duct	Use double acting damper.



MULTIPLE LOUVER DAMPER ASSEMBLY
(FOR ASSEMBLY EXCEEDING MAXIMUM DIMENSIONS)

MATERIAL SPECIFICATIONS

Maximum Over-all Height	91½"
Maximum Over-all Width	50"
Maximum Blade Width	12"
Frame — Top and Bottom	3" x 1/8" flat bar
— Sides	3" x 7/8" x 1/8" hat channel
Blades	16 U.S. gage steel
Bearing	Oil-retaining porous bronze
Blade Linkage Rod	5/16" dia. CRS
Trunnion	Die-formed steel
Blade Link (Multi-section)	Stainless steel bar

BLADES

DAMPER HEIGHT (in.)	NUMBER OF BLADES
To and incl. 12-11/16	1
12¾ thru 21½	2
219/16 thru 31½	3
319/16 thru 41½	4
419/16 thru 51½	5
519/16 thru 61½	6
619/16 thru 71½	7
719/16 thru 81½	8
819/16 thru 91½	9

Fig. 4 – Louver Damper Arrangements

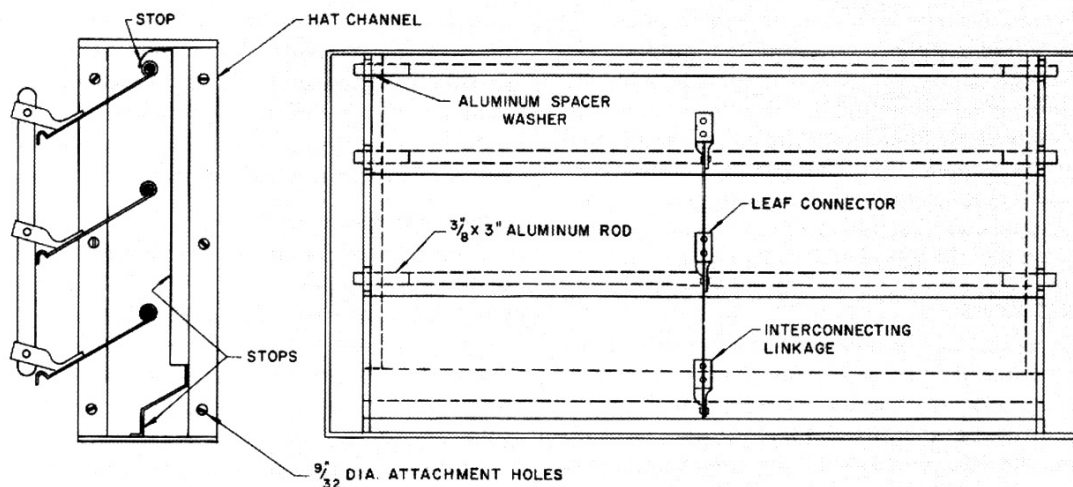

SINGLE RELIEF DAMPER

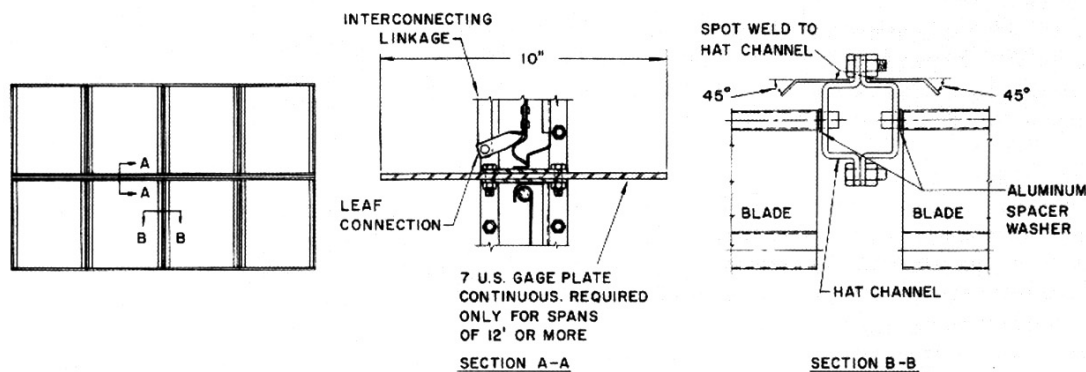

MULTIPLE RELIEF DAMPER ASSEMBLY
(FOR ASSEMBLY EXCEEDING MAXIMUM DIMENSION)

MATERIAL SPECIFICATIONS

Maximum Over-all Height	91 1/2"
Maximum Over-all Width	40"
Maximum Blade Width	3 1/2"
Frame – Top and Bottom	3" wide, 11 gage black iron
– Sides	3" x 7/8" x 1/8" hat channel
Blades	22 B & S gage aluminum
Blade Linkage Rod	1/2" wide, 0.050" aluminum
Spacer Washer	3/8" ID x 1/2" OD aluminum

PRESSURE DROP

FACE VELOCITY (fpm)	PRESSURE DROP (in. wg)
400	.067
500	.084
600	.120
700	.160
800	.200
900	.256

Fig. 5 – Relief Damper

RELIEF DAMPERS

Figure 5 shows a typical relief damper. This accessory is used as a check damper on exhaust systems, and to relieve excess pressure from the building.

AIR CLEANING EQUIPMENT

A variety of air filtering devices is available, each with its own application. The pressure drop across these devices must be included when totaling the static pressure against which the fan must operate. Filters are described in detail in *Part 6*.

HEATING COILS

Heating coils can be used with steam or hot water. They are used for preheating, and for tempering or reheating. The air velocity thru the coil is determined by the air quantity and the coil size. The size may also be determined by a space limitation or by the recommended limiting velocity of 500 to 800 fpm. The number of rows and fin spacing is determined by the required temperature rise. Manufacturer's data lists pressure drop and capacity for easy selection.

Steam coils must be installed so that a minimum of 18 in. is maintained between the condensate outlet and the floor to allow for traps and condensate piping.

Preheat Coils

Non-freeze coils are recommended for preheat service, particularly if air below the freezing temperature is encountered. To reduce the coil first cost, the preheater is often sized and located in only the minimum outdoor air portion of the air handling apparatus. If a coil cannot be selected at the required load and desired steam pressure, it is better to make a selection that is slightly undersize than one that is oversize. An undersized coil aids in preventing coil freeze-up.

The use of two coils for preheating also minimizes the possibility of freeze-up. The first coil is deliberately selected to operate with full steam pressure at all times during winter operation. In this instance, the air is heated from outdoor design to above the freezing temperature. The second coil is selected to heat the air from the freezing temperature to the desired leaving temperature. The temperature of the air leaving the second coil is automatically controlled. Refer to *Part 3, "Freeze-up Protection."*

In addition to the normal steam trap required to drain the coil return header, a steam supply trap immediately ahead of the coil is recommended. These traps must be located outside the apparatus casing.

Most coils are manufactured with a built-in tube pitch to the return header. If the coil is not constructed in this

manner, it must be pitched toward the return header when it is installed.

To minimize coil cleaning problems, filters should be installed ahead of the preheaters.

Reheat or Tempering Coils

Coils selected for reheat service are usually oversized. In addition to the required load, a liberal safety factor of from 15% to 25% is recommended. This allows for extra load pickup during early morning operation, and also for duct heat loss which can be particularly significant on long duct runs.

These coils are similar to preheat coils in that the tubes must be pitched toward the return header.

COOLING COILS

Cooling coils are used with chilled water, well water or direct expansion for the purpose of precooling, cooling and dehumidifying or for after cooling. The resulting velocity thru the cooling coil is dictated by the air quantity, coil size, available space, and the coil load. Manufacturer's data gives recommended maximum air velocities above which water carry-over begins to occur.

SPRAYS AND ELIMINATORS

Spray assemblies are used for humidifying, dehumidifying or washing the air. One item often overlooked when designing this equipment is the bleeder line located on the discharge side of the pump. In addition to draining the spray heads on shutdown, this line controls the water concentrates in the spray pan. See *Part 5, Water Conditioning*. Eliminators are used after spray chambers to prevent entrained water from entering the duct system.

AIR BYPASS

An air bypass is used for two purposes: (1) to increase room air circulation and (2) to control leaving air temperature.

The fixed bypass is used when increased air circulation is required in a given space. It permits return air from the room to flow thru the fan without first passing thru a heat exchange device. This arrangement prevents stagnation in the space and maintains a reasonable room circulation factor.

The total airway resistance for this type system is the sum of the total resistance thru the ductwork and air handling apparatus. Therefore, the resistance thru the bypass is normally designed to balance the resistance of the components bypassed. This can be accomplished by using a balancing damper and by varying the size of the bypass opening.

The following formula is suggested for use in sizing the bypass opening :

$$A = \frac{\text{cfm}}{581 \sqrt{\frac{h}{.0707}}}$$

where : A = damper opening (sq ft)
 cfm = maximum required air quantity thru bypass
 h = design pressure drop (in. wg) thru bypassed equipment

Temperature control with bypassed air is accomplished with either a face and bypass damper or a controlled bypass damper alone. However, the face and bypass damper arrangement is recommended, since the bypass area becomes very large, and it is difficult to accommodate the required air flow thru the bypass at small partial loads. Even where a controlled face and bypass damper is used, leakage approaching 5% of design air quantity passes thru the face damper when the face damper is closed. This 5% air quantity normally is included when the fan is selected.

See *Part 6* for systems having a variable air flow to determine fan selection and brake horsepower requirements.

FANS

Properly designed approaches and discharges from fans are required for rated fan performance in addition to minimizing noise generation. *Figures 6 and 7* indicate several possible layouts for varying degrees of fan performance. In addition, these figures indicate recommended location of double width fans in plenums. When these minimums have not been met, it becomes increasing difficult to guarantee the fan performance or to accurately determine air quantities.

Fans in basement locations require vibration isolation based on the blade frequency. Usually cork or rubber isolators are satisfactory for this service. On upper floor locations, however, spring mounted concrete bases designed to absorb the lowest natural frequency are recommended.

The importance of controlling sound and vibration cannot be overstressed, particularly on upper floors. The number of fans involved in one location and the quality of sound and vibration control needed.

Small direct connected fans, due to higher operating speed, are generally satisfactorily isolated by rubber or cork.

In addition, all types of fans must have flexible connections to the discharge ductwork and, where required, must have flexible connections to the intake ductwork. Details of a recommended flexible connection are shown in *Fig.8*.

Unitary equipment should be located near columns or over main beams to limit the floor deflection. Rubber or cord properly loaded usually gives the required deflection for efficient operation.

FAN MOTOR AND DRIVE

A proper motor and drive selection aids in long life and minimum service requirements. Direct drive fans are normally used on applications where exact air quantities are not required, because ample energy (steam or hot water, etc.) is available at more than enough temperature difference to compensate for any lack of air quantity that exists. This applies, for example, to a unit heater application. Direct drive fans are also used on applications where system resistance can be accurately determined. However, most air conditioning applications use belt drives.

V-belts must be applied in matched sets and used on balanced sheaves to minimize vibration problems and to assure long life. They are particularly useful on applications where adjustments may be required to obtain more exact air quantities. These adjustments can be accomplished by varying the pitch diameter on adjustable sheaves, or by changing one or both sheaves on a fixed sheave drive.

Belt guards are required for safety on all V-belt drives, and coupling guards are required for direct drive equipment. *Figure 9* illustrates a two-piece belt guard.

The fan motor must be selected for the maximum anticipated brake horsepower requirements of the fan. The motor must be large enough to operate within its rated horse power capacity. Since the fan motor runs continuously, the normal 15% over load allowed by NEMA should be reserved for drive losses and reductions in line voltages. Normal torque motors are used for fan duty.

APPARATUS CASING

The apparatus casing on central station equipment must be designed to avoid restrictions in air flow. In addition, it must have adequate strength to prevent collapse or bowing under maximum operating conditions.

Each sheet of material should be fabricated as a panel and joined together, as illustrated in *Fig 10*, by standing seams bolted or riveted on 12 in. centers.

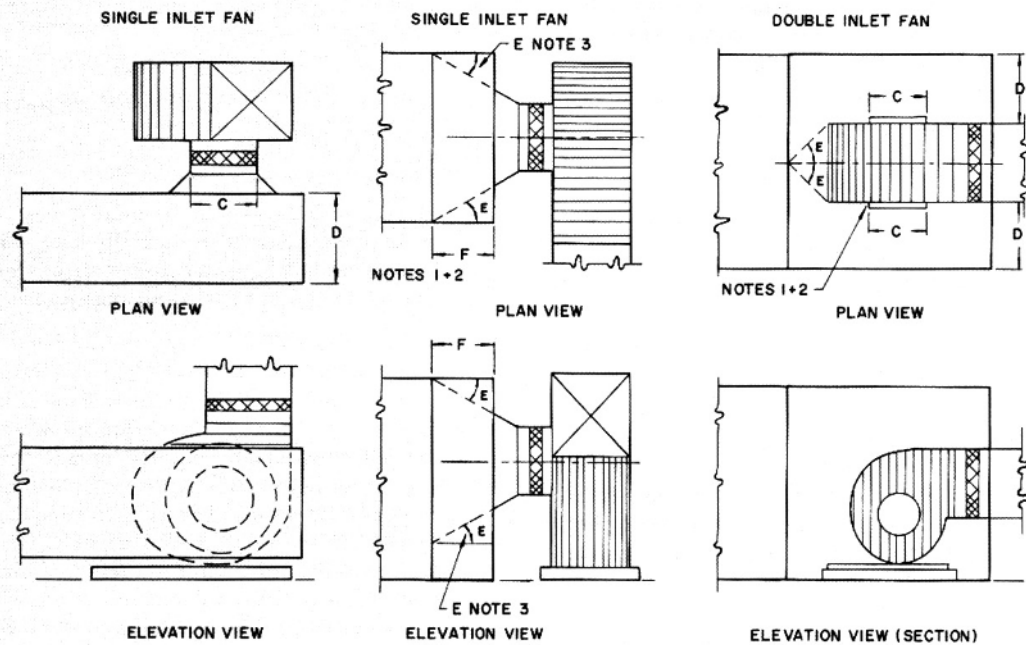

DIMENSIONS:
 C = DIAMETER OF FAN INLET
 $D = 1\frac{1}{4} \times C$

E = 45° MAXIMUM 30° PREFERRED
F = 36" MINIMUM FOR ACCESS DOOR

INLET CONNECTIONS

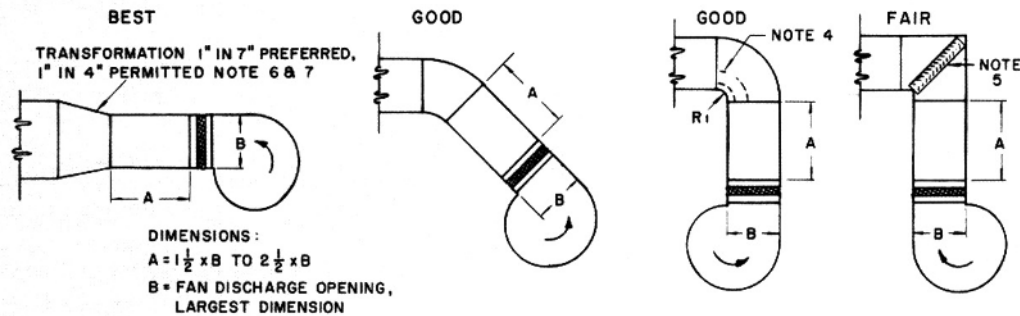

DIMENSIONS:
 $A = 1\frac{1}{2} \times B$ TO $2\frac{1}{2} \times B$
 B = FAN DISCHARGE OPENING, LARGEST DIMENSION

DISCHARGE CONNECTIONS

NOTES:

1. Fan should be centered in casing to provide good flow conditions.
2. All equipment should be centered for best performance.
3. Angle "E" is used to determine "F" distance between equipment and fan.
4. $R_1 = 6"$ minimum. Vane spacing determined from Chart 6.
5. Use square vaned elbow for best results, with take-off in opposite direction to fan rotation.
6. Slope of 1" in 4" recommended for low velocity.
7. Slope of 1" in 7" recommended for high velocity.

Fig. 6 – Single Fan Inlet and Discharge Connections

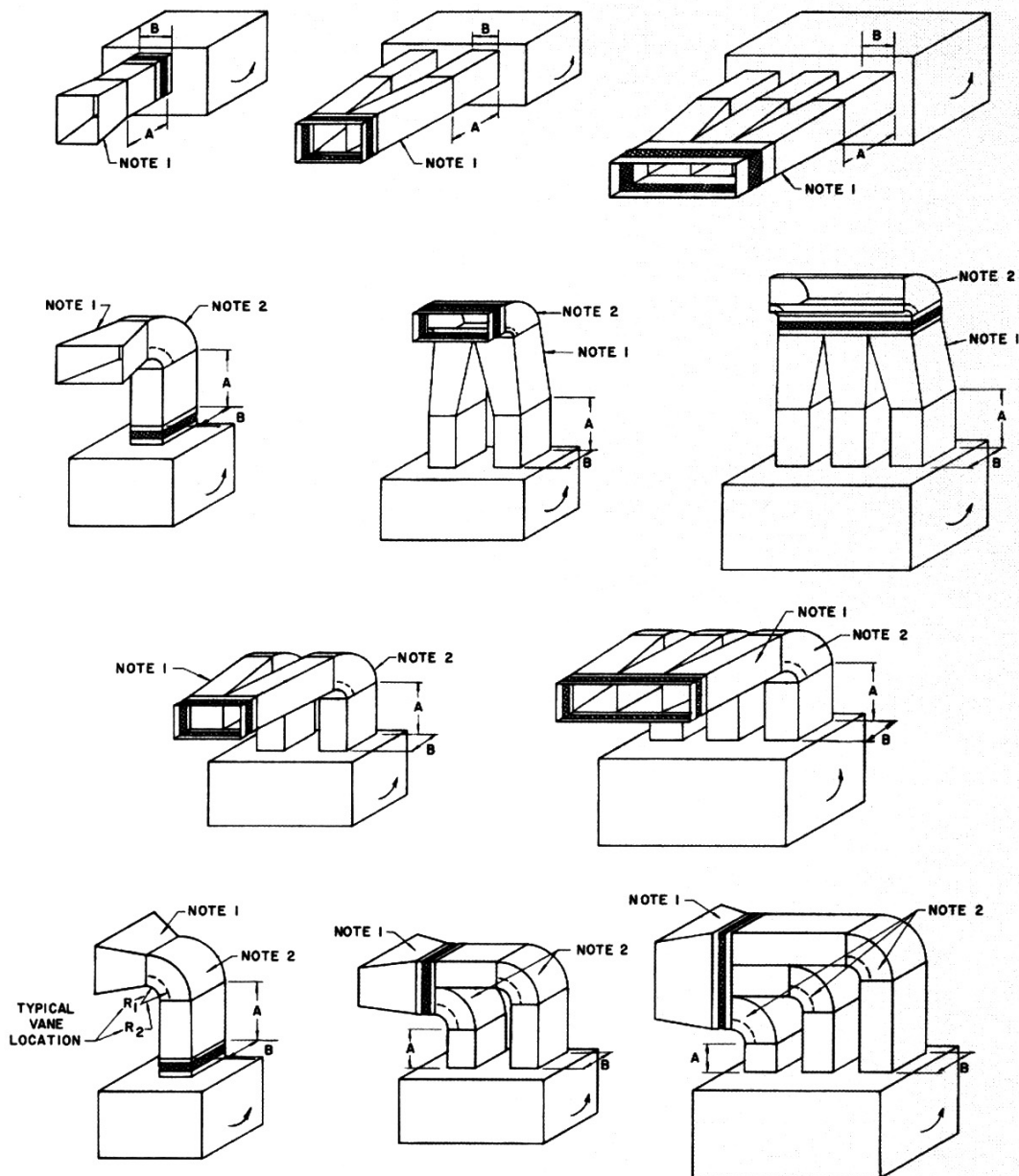

$R_1 = 6"$, R_2 DETERMINED FROM CHART 6, VANE SPACING
 $A = 1\frac{1}{2} B$ TO $2\frac{1}{2} B$
 $B =$ LONGEST DIMENSION OF OUTLET OPENING

- NOTES:**
1. Transformations to supply duct have maximum slope of 1" in 7".
 2. Square elbows with double thickness vanes may be substituted.
 3. Do not install ducts so that the air flow is counter to fan rotation. If necessary, turn fan section.
 4. Transformations and units shall be adequately supported so no weight is on the flexible fan connection.

Fig. 7 – Multiple Fan Unit Discharge Connections

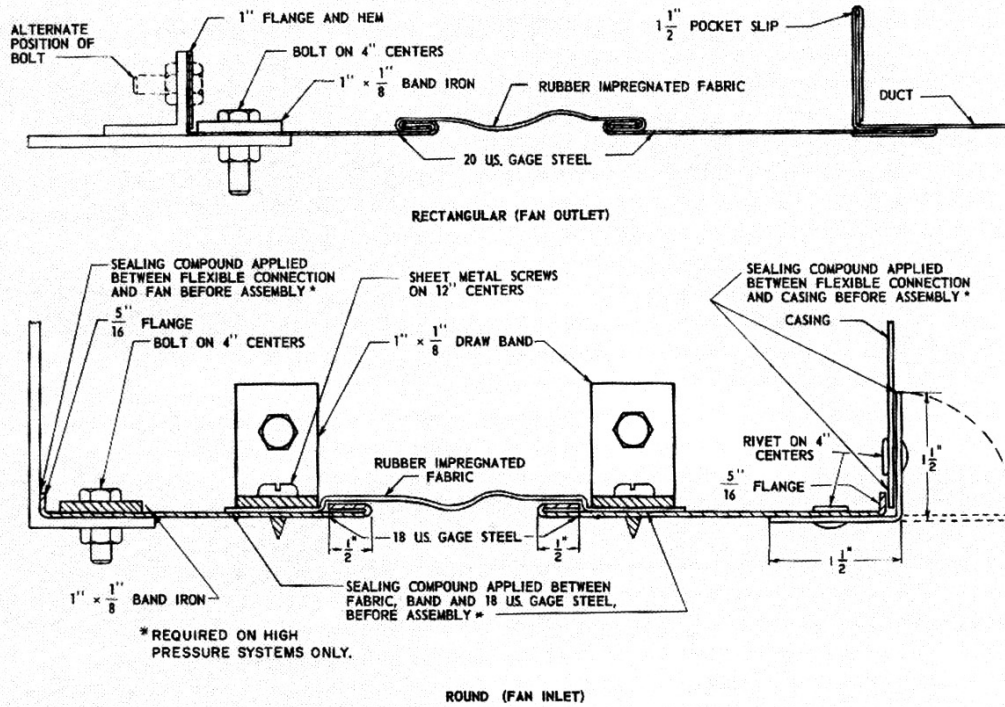

Fig. 8 – Flexible Connection

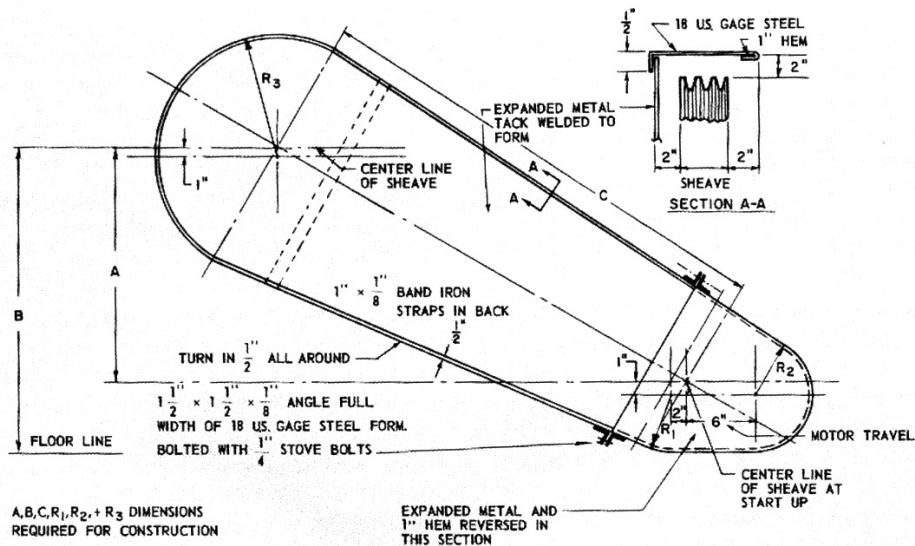

Fig. 9 – Two-piece Belt Guard

Normally seams perpendicular to air flow are placed outside of the casing. Side walls over 6 ft high and roof spans over 6 ft wide require supplemental reinforcing as shown in Table 2. Diagonal angle braces as illustrated in Fig. 11 may also be required.

The recommended construction of apparatus casings and connections between equipment components (except when mounted in the ducts) is 18 U.S. gage steel of 16 B & S gage aluminum. Aluminum in contact with galvanized steel at connections to spray type equipment requires that the inside of the casing be coated with an isolating material for a distance of 6 in. From the point of contact.

CONNECTIONS TO MASONRY

A concrete curb is recommended to protect insulation from deteriorating where the apparatus casing joins the floor. It also provides a uniform surface for attaching the casing; this conserves fabrication time. Figure 123 illustrates the recommended method of attaching a casing to the curb.

When an equipment room wall is used as one side of the apparatus, the casing is attached as shown in Fig.13.

The degree of tightness required for an apparatus casing depends on the air conditioning application. For instance, on a pull-thru system, leakage between the dehumidifier and the fan cannot be tolerated if

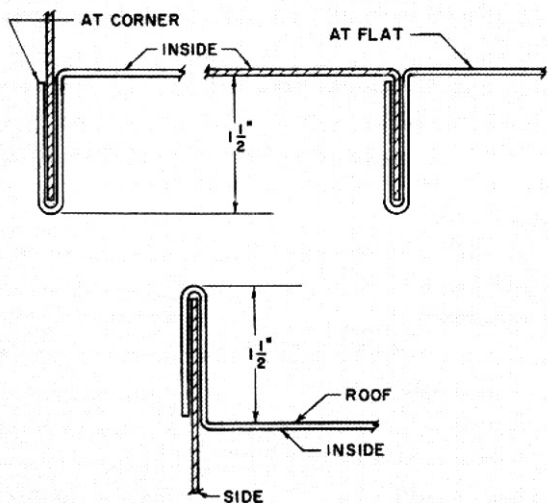

Fig. 10 – Apparatus Casing Seams

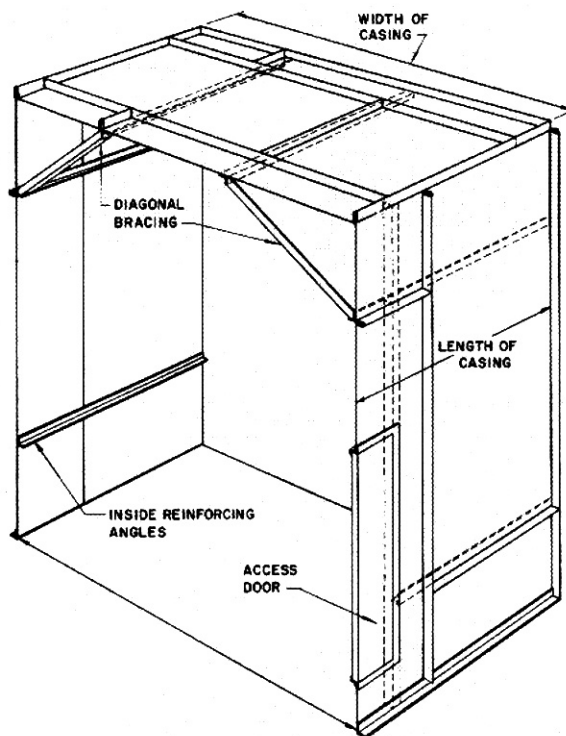

Fig. 11 – Apparatus Casing

TABLE 2—SUPPLEMENTAL REINFORCING FOR APPARATUS CASING

SIDE WALL HEIGHT OR ROOF WIDTH (ft)	NUMBER OF ANGLES*	ANGLE SPACING	CASING LENGTHS	DIAGONAL ANGLE BRACES* (pairs)
6 to 8	1	middle	—	—
8 to 12	2	1/3 points	—	—
over 12	variable	4 ft centers	3 & 4 panels 5 & 6 panels 7 & 8 panels	1 2 3

*For lengths up to 12 ft., use 1 1/2 x 1 1/2 x 1/8 in. angle. For lengths over 12 ft., use 1 3/4 x 1 3/4 x 3/8 in. angle.

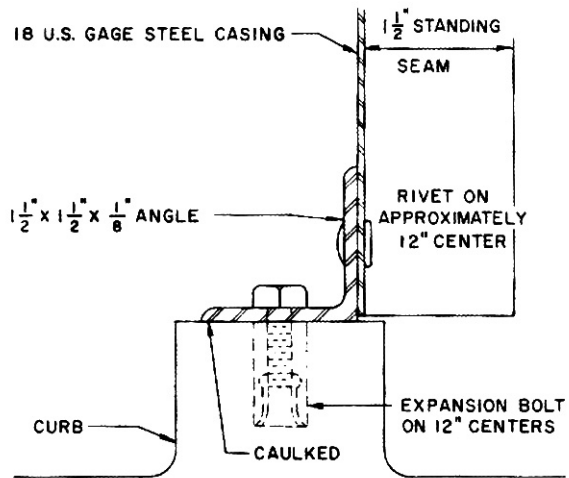

Fig. 12 - Connection to Masonry Curb

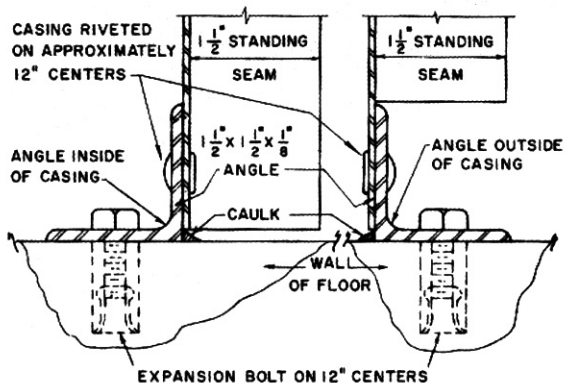

Fig. 13 - Connection to Masonry Wall

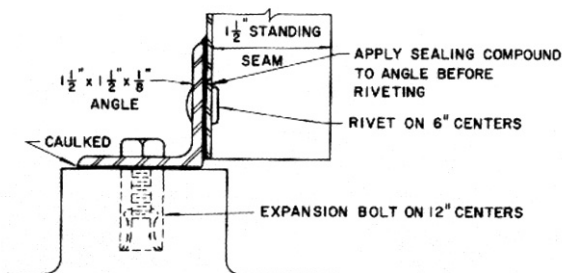

Fig. 14 - Low Dewpoint Masonry Curb Connections

the apparatus is in a humid non-conditioned space, Also, as the negative pressure at the fan intake increases, the less the leakage that can be tolerated. If the apparatus is located in a return air plenum, normal construction as shown in *Figs. 12 and 13* can be used. Corresponding construction practice for equipment requiring extreme care is shown in *Figs. 14, 15 and 16*.

In addition to the construction required for leakage at seams, pipes passing thru the casing at cooling coil connections must be sealed as shown in *Fig. 17*, This applies in applications where the temperature difference between the room and supply air temperatures is 20 F and greater.

DRAINS AND MARINE LIGHTS

Upkeep and maintenance is better on an apparatus that can be illuminated and easily cleaned than on one that does not have good illumination and drainage. To facilitate this maintenance, marine lights, as well as drains, are recommended as shown in *Fig. 1*.

As a rule of thumb, drains should be located in the air handling apparatus wherever water is likely to accumulate, either in normal operation of the equipment or because of maintenance. Specific examples are:

1. In the chamber immediately after the outdoor air louver where a driving rain or snow may accumulate.
2. Before and after filters that must be periodically washed.
3. Before and after heating and cooling coils that must be periodically cleaned.
4. Before and after eliminators because of backlash and carry-over due to unusual air eddies.

Drains should not normally be connected directly to sewers. Instead, an open site drain should be used as illustrated in *Part 3*.

INSULATION

Insulation is required ahead of the preheater and vapor sealed for condensation during winter operation. Normally, the section of the casing from the preheater to the dehumidifier is not insulated. The dehumidifier, the fan and connecting casing must be insulated and vapor sealed; fan access doors are not insulated, however, The bottoms and sides of the dehumidifier condensate pan must also be insulated, and all parts of the building surfaces that are used to form part of the apparatus casing must be insulated and vapor sealed.

SERVICE

Equipment service is essential and space must be provided to accomplish this service. It is recommended that minimum clearances be maintained so that access to

all equipment is available. In addition, provision should be made so that equipment can be removed without dismantling the complete apparatus. Access must be provided for heating and cooling coils, steam traps, damper motors and linkages, control valves, bearings, fan motors, fans and similar components.

Service access doors as illustrated in Fig. 18 are recommended, and are located in casing sections shown in Fig. 1.

To conserve floor space, the entrance to the equipment room is often located so that coils can be removed directly thru the equipment room doors. This arrangement requires less space than otherwise possible.

If the equipment room is not arranged as described, space must be allowed to clean the coil tubes mechanically. This applies to installations that have removable water headers.

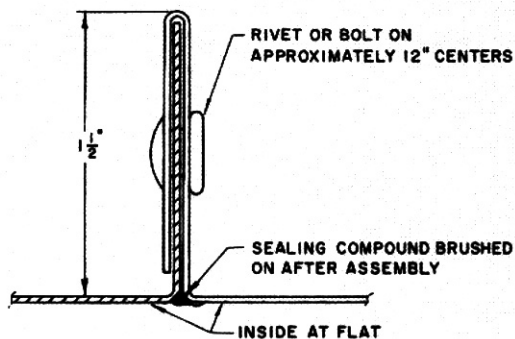

Fig. 16 – Sealing Standing Seams

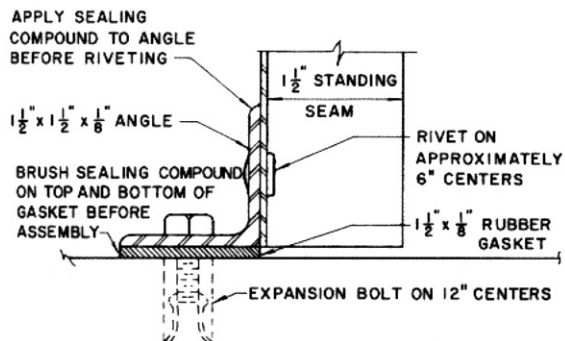

Fig. 15 – Low Dewpoint Masonry Wall Connections

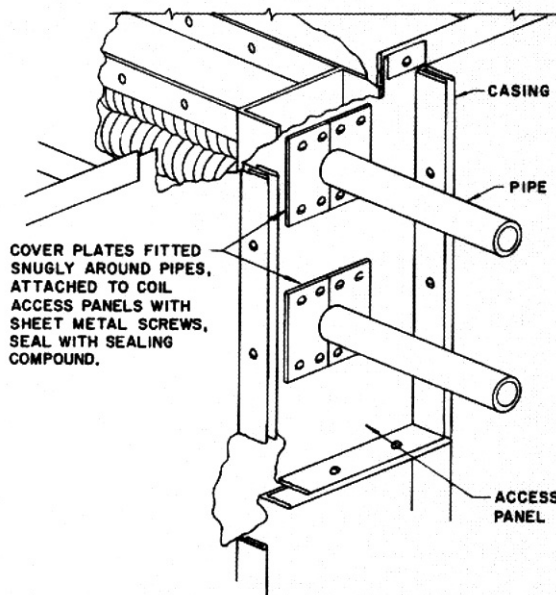
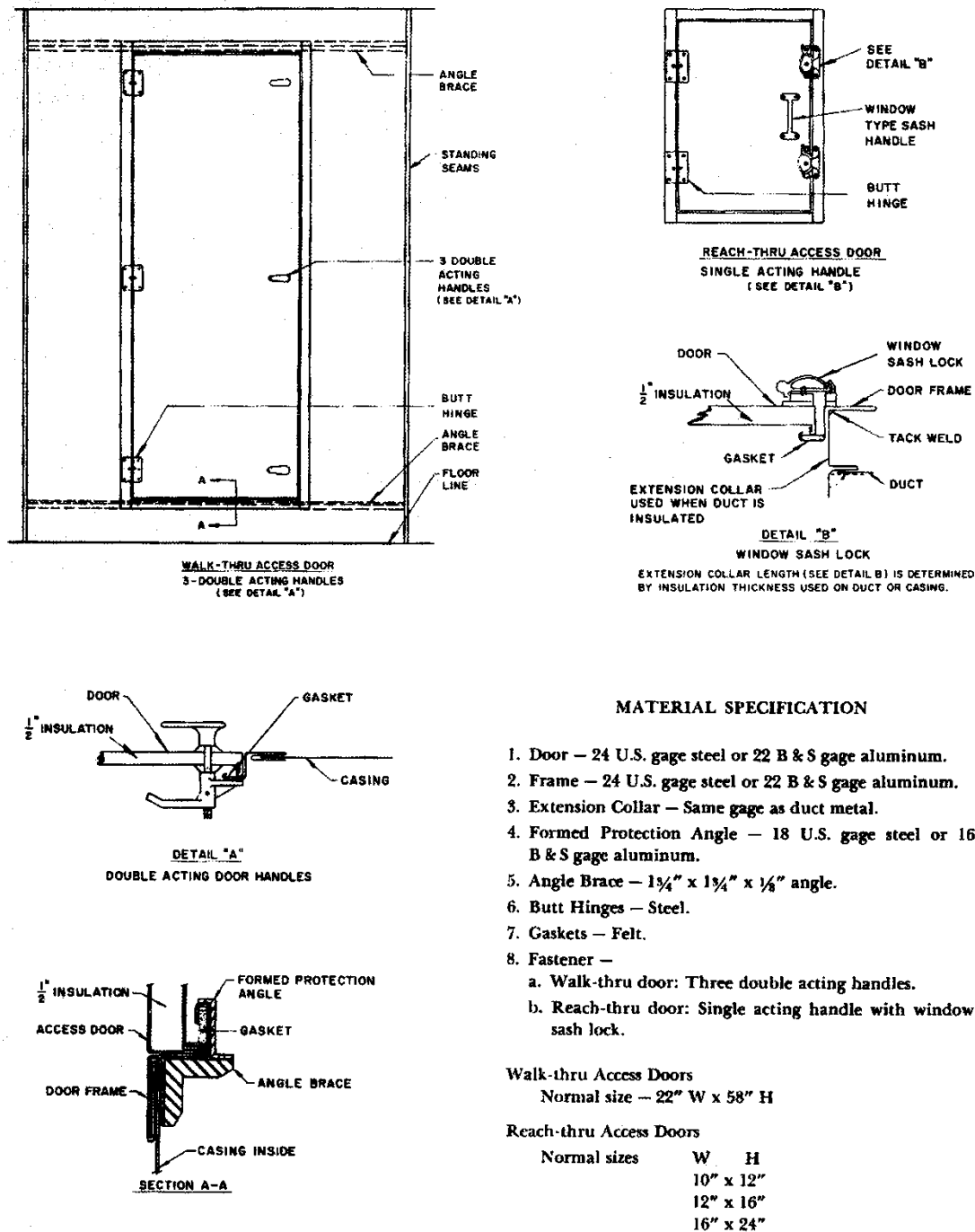

Fig. 17 – Sealing Pipe Connections



MATERIAL SPECIFICATION

1. Door – 24 U.S. gage steel or 22 B & S gage aluminum.
2. Frame – 24 U.S. gage steel or 22 B & S gage aluminum.
3. Extension Collar – Same gage as duct metal.
4. Formed Protection Angle – 18 U.S. gage steel or 16 B & S gage aluminum.
5. Angle Brace – 1 1/4" x 1 1/4" x 1/8" angle.
6. Butt Hinges – Steel.
7. Gaskets – Felt.
8. Fastener –
 - a. Walk-thru door: Three double acting handles.
 - b. Reach-thru door: Single acting handle with window sash lock.

Walk-thru Access Doors
Normal size – 22" W x 58" H

Reach-thru Access Doors

Normal sizes	W	H
	10"	12"
	12"	16"
	16"	24"

Fig. 18 – Access Doors

CHAPTER 2. AIRDUCT DESIGN

The function of a duct system is to transmit air from the air handling apparatus to the space to be conditioned.

To fulfill this function in a practical manner, the system must be designed within the prescribed limits of available space, friction loss, velocity, sound, level, heat and leakage losses and gains.

This chapter discusses these practical design criteria and also considers economic balance between first cost and operating cost. In addition, it offers recommended construction for various types of duct systems.

GENERAL SYSTEM DESIGN

CLASSIFICATION

Supply and return duct systems are classified with respect to the velocity and pressure of the air within the duct.

Velocity

There are two types of air transmission systems used for air conditioning applications. They are called conventional or low velocity and high velocity systems. The dividing line between these systems is rather nebulous but, for the purpose of this chapter, the following initial supply air velocities are offered as a guide:

1. Commercial comfort air conditioning
 - a. Low velocity – up to 2500 fpm. Normally between 1200 and 2200 fpm.
 - b. High velocity – above 2500 fpm.
2. Factory comfort air conditioning
 - a. Low velocity - up to 2500 fpm. Normally between 2200 and 2500 fpm.
 - b. High velocity – 2500 to 5000 fpm.

Normally, return air systems for both low and high velocity supply air systems are designed as low velocity systems. The velocity range for commercial and factory comfort application is as follows:

1. Commercial comfort air conditioning – low velocity up to 2000 fpm. Normally between 1500 and 1800 fpm.
2. Factory comfort air conditioning – low velocity up to 2500 fpm. Normally between 1800 and 2200 fpm.

Pressure

Air distribution systems are divided into three pressure categories; low, medium and high. These divisions have the same pressure ranges as Class I, II and III fans as indicated:

1. Low pressure – up to $3\frac{3}{4}$ in. wg – Class I fan
2. Medium pressure – $3\frac{3}{4}$ to $6\frac{3}{4}$ in. wg – Class II fan
3. High pressure – $6\frac{3}{4}$ to $12\frac{1}{4}$ in. wg – Class III fan

These pressure ranges are total pressure, including the losses thru the air handling apparatus, ductwork and the air terminal in the space.

AVAILABLE SPACE AND ARCHITECTURAL APPEARANCE

The space allotted for the supply and return air conditioning ducts, and the appearance of these ducts often dictates system layout and, in some instances, the type of system layout and, in some instances, the type of system. In hotels and office buildings where space is at a premium, a high velocity system with induction units using small round ducts is often the most practical.

Some applications require the ductwork to be exposed and attached to the ceiling, such as in an existing department store or existing office building. For this type of application, streamline rectangular ductwork is ideal. Streamline ductwork is constructed to give the appearance of a beam on the ceiling. It has a smooth exterior surface with the duct joints fabricated inside the duct. This ductwork is laid out with a minimum number of reductions in size to maintain the beam appearance.

Duct appearance and space allocation in factory air conditioning is usually of secondary importance. A conventional system using rectangular duct work is probably the most economical design for this application.

ECONOMIC FACTORS INFLUENCING DUCT LAYOUT

The balance between first cost and operating cost must be considered in conjunction with the available space for the duct work to determine the best air distribution system. Each application is different and must be analyzed separately; only general rules or principles can be given to guide the engineer in selecting the proper system.

CHART 3 – DUCT HEAT GAIN VS ASPECT RATIO

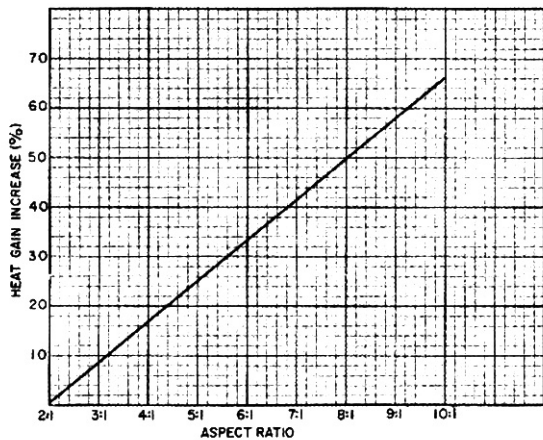

The following items directly influence the first and operating cost:

1. Heat gain or loss from the duct
2. Aspect ratio of the duct
3. Duct friction rate
4. Type of fittings

Heat Gain or Loss

The heat gains or losses in the supply and return duct system can be considerable. This occurs not only if the duct passes through an unconditioned space but also on long duct in the unconditioned space when estimating the air conditioning load. The method of making this allowance is presented in Part I, Load Estimating. This allowance for duct heat gain increases the cooling capacity of the air. This increase then requires a larger air quantity or lower supply air quantity or lower supply air temperature or both.

To compensate for the cooling or heating effect of the duct surface, a redistribution of the air to the supply outlets is sometimes required in the initial design of the duct system.

The following general guides are offered to help the engineer understand the various factors influencing duct design:

1. Larger duct aspect ratios have more heat gain than ducts with small aspect ratios, with each carrying the same air quantity. Chart 3 illustrates this relationship.
2. Ducts carrying small air quantities at a low velocity have the greatest heat gain.
3. The addition of insulation to the duct decreases duct heat gain; for example, insulating the duct

with a material that has a U value of .12 decreases heat gain 90%

It is, therefore, good practice to design the duct system for low aspect ratios and higher velocities to minimize heat gain to the duct. If the duct is to run through an unconditioned area, it should be insulated.

Aspect Ratio

The aspect ratio is the ratio of the long side to the short side of a duct. This ratio is an important factor to be considered in the initial design. Increasing the aspect ratio increases both the installed cost and the operating cost of the system.

The installed or first cost of the duct work depends on the amount of material used and the difficulty experienced in fabricating the ducts. Table 6 reflects these factors. This table also contains duct class, cross-section area for various round duct sizes and the equivalent diameter of round duct for rectangular ducts. The large numbers in the table are the duct class.

The duct construction class varies from 1 to 6 and depends on the maximum duct side and the semi-perimeter of the ductwork. This is illustrated as follows:

DUCT CLASS	MAX. SIDE (in.)	SEMI-PERIMETER (in.)
1	6 – 17 1/2	10 – 23
2	12 – 24	24 – 46
3	26 – 40	32 – 46
4	24 – 88	48 – 94
5	48 – 90	96 – 176
6	90 – 144	96 – 238

Duct class is a numerical representation of relative first costs of the duct work. The larger the duct class, the more expensive the duct. If the duct class is increased but the duct area and capacity remain the same, the following items may be increased:

1. Semi-perimeter and duct surface
2. Weight of material
3. Amount of insulation required

Therefore, for best economics the duct system should be designed for the lowest duct class at the smallest aspect ratio possible. Example 1 illustrates the effect on first cost of varying the aspect ratio for a specified air quantity and static pressure requirement.

Example 1 – Effect of Aspect Ratio on First Cost of the Ductwork

Given:

- Duct cross-section area – 5.86 sq. ft.
- Space available – unlimited
- Low velocity duct system

Find:

The duct dimensions, class, surface area, weight and gage of metal required.

Solution:

1. Enter Table 6 at 5.86 sq. ft and determine the rectangular duct dimensions and duct class (see tabulation).
2. Determine recommended metal gages from Tables 14 and 15 (see tabulation).
3. Determine weight of metal from Table 18 (see tabulation).

DIMENSION (in.)	AREA (sq ft)	ASPECT RATIO	DUCT CONSTR. CLASS
94 X 12	5.86	7.8 : 1	6
84 X 13	5.86	6.5 : 1	5
76 X 14	5.86	5.4 : 1	4
42 X 22	5.86	1.9 : 1	4
30 X 30	5.86	1 : 1	4
32.8 (round)	5.86	-	-

DIMENSION (in.)	GAGE (U.S.)	SURFACE AREA (sq ft/ft)	WEIGHT (lb/ft)
94 X 12	18	17.7	38.3
84 X 13	20	16.2	26.8
76 X 14	20	15.0	24.8
42 X 22	22	10.7	15.1
30 X 30	24	10.0	11.6
32.8 (round)	20	8.6	14.3

When the aspect ratio increases from 1:1 to 8:1, the surface area and insulation requirements increase 70% and the weight of metal increases over three and one-half times. This example also points out that it is possible to construct Class 4 duct, for the given area, with three different sheet metal gages. Therefore, for lowest first cost, ductwork should be designed for the lowest class, smallest aspect ratio and for the lightest gage metal recommended.

Chart 4 illustrates the percent increase in installed cost for changing the aspect ratio of rectangular duct. The installed cost of round duct is also included in this chart. The curve is based on installed cost of 100 ft of round and rectangular duct with various aspect ratios of 1:1 is used as the 100% cost

Friction rate

The operating costs of an air distribution system can be adversely influenced when the rectangular duct sizes are not determined from the table of circular equivalents (Table 6). This table is used to obtain rectangular duct sizes that have the same friction rate and capacity as the equivalent round duct. For example, assume that the required duct area for a system is 480 sq. in. and the

rectangular duct dimensions are determined directly from this area. The following tabulation shows the resulting equivalent duct diameters and friction rate when 4000 cm. of air is handled in the selected ducts:

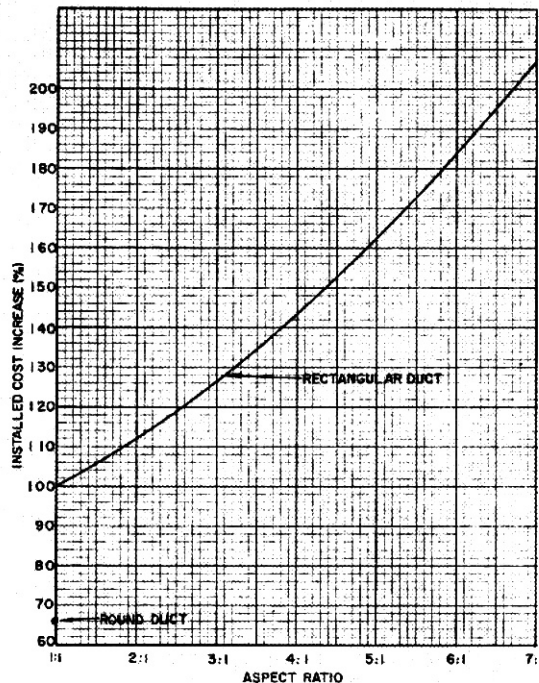

CHART 4 – INSTALLED COST VS ASPECT RATIO

DUCT DIM. (in.)	EQUIV ROUND DUCT DIAM (in.)	FRICTION RATE (in. wg/100ft)	ASPECT RATIO
24 X 20	23.9	.090	1.2 : 1
30 X 16	23.7	.095	1.9 : 1
48 X 10	22.3	.125	4.8 : 1
80 X 6	20.1	.210	13.3 : 1

If a total static pressure requirement of 1 in., based on 100 ft of duct and other equipment is assumed for the above system, the operating cost increases as the aspect ratio increases. This is shown in Chart 5.

Therefore, the lowest owning and operating cost occurs where round or Spira-Pipe is used. If round ductwork can not be used because of space limitations, ductwork as square as possible should be used. An aspect ratio of 1:1 is preferred.

Type of Fittings

In general, fittings can be divided into Class A and Class B as shown in *Table 3*. For the lowest first cost it is desirable to use those fittings shown as Class A since fabrication time for a Class B fitting is approximately 2.5 times that of a Class A fitting.

CHART 5 – OPERATING COST VS ASPECT RATIO

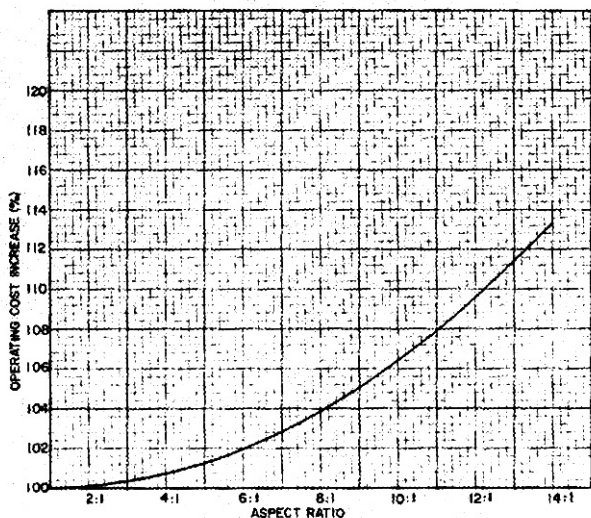

TABLE 3 – DUCT FITTING CLASSES

CLASS A—NO VANED FITTINGS	
Any fitting with constant cross-section dimensions.	
Any fitting with changing radius and constant width.	
Fittings with straight sides and seams.	
CLASS B—ALL VANED FITTINGS	
Any fitting with concentric radii, and changing width.	
Any fitting with eccentric radii and changing width.	

DUCT LAYOUT CONSIDERATIONS

There are several items in duct layout that should be considered before sizing the ductwork, These include duct transformations, elbows, fittings, take-offs, duct condensation and duct condensation and air control.

Transformations

Duct transformations are used to change the shape of a duct of to increase of decrease the duct area. When the shape of a rectangular duct is changed but the cross-sectional area remains the same, a slope of 1 in. in 4 in. should not be exceeded.

Often ducts must be reduced in size to avoid obstructions. It is good practice not to reduce the duct more than 20% of the original area. The recommended slope of the transformation is 1 in. in 7 in. when reducing the duct area. Where it is impossible to maintain this slope, it may be increased to a maximum of 1 in. in 4 in.

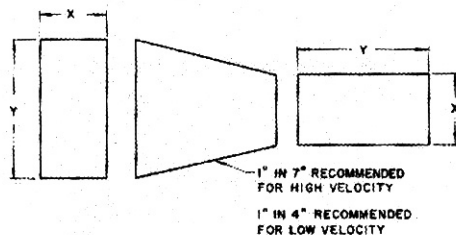
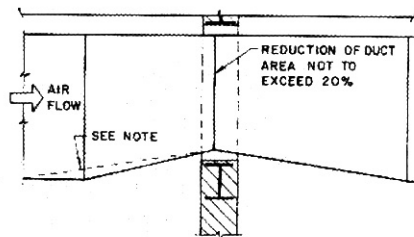

Fig. 19 – Duct Transformation



NOTE: 1:7 slope is recommended for high velocity, 1:4 slope for low velocity.

Fig. 20 – Rectangular Duct Transformation To Avoid Obstruction

When the duct area is increased, the slope of the transformation is not to exceed 1 in. in 7 in. Fig. 20 illustrates a rectangular duct transformation to avoid an obstruction, and Fig. 21 shows a round-to rectangular transformation to avoid an obstruction.

In some air distribution systems, equipment such as heating coils is installed in the duct work. Normally the equipment is larger than the duct work and the duct area must be increased. The slope of the transformation piece on the upstream side of the equipment is limited to 30° as shown in Fig. 22. On the leaving side the slope should be not more than 45°

Duct Reduction Increments

Accepted methods of duct design usually indicate a reduction a reduction in duct area after each terminal and branch take-off. Unless a reduction of at least 2 in. can be made, however, it is recommended that the original duct size be maintained. Savings in installed cost of as much as 25% can be realized by running the duct at the same size for several terminals.

All duct sizes should be in 2in. increments, preferably in one dimension only. The recommended minimum duct size is 8 in. x 10 in. for fabricated shop ductwork.

Obstructions

Locating pipes, electrical conduit, structural members and other items inside the ductwork should always be avoided, especially in elbows and tees. Obstruction of any kind must be avoided inside high velocity. Obstructions cause unnecessary pressure loss and, in a high velocity system, may also be a source of noise in the air stream.

In those few instances in which obstructions must pass thru the duct, use the following recommendations:

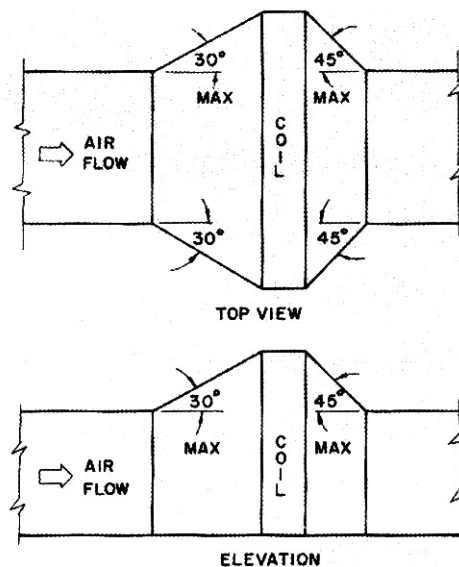

NOTE: Angles shown are for low velocities. 1:7 slope is recommended for high velocities.

Fig. 22 – Duct Transformation With Equipment in the Duct

1. Cover all pipes and circular obstructions over 4 in. in diameter with an easement. Two typical easements are illustrated in Fig. 23.
2. Cover any flat or irregular shapes having a width exceeding 3 in. with an easement. Hangers or stays in the duct should be parallel to the air flow. If this is not possible, they should be covered with an easement, Fig. 24 shows a tear drop-shaped easement covering an angle. Hanger "B" also requires an easement.

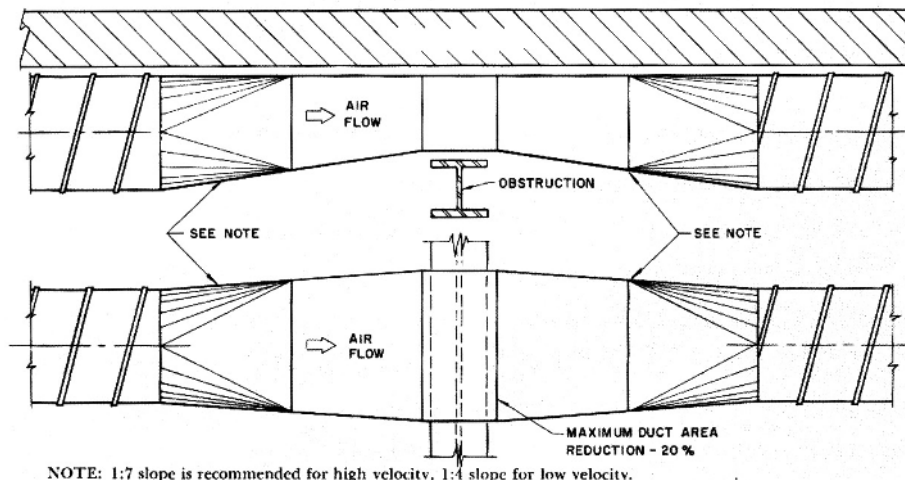

Fig. 21 – Round Duct Transformation to Avoid Obstruction

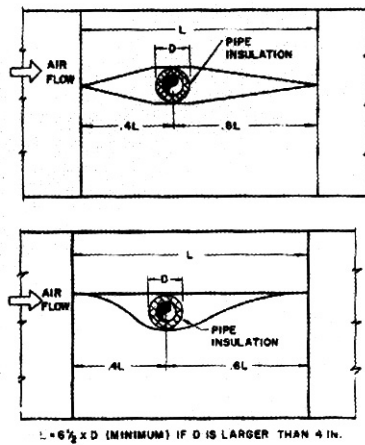

Fig. 23 – Easements Covering Obstructions

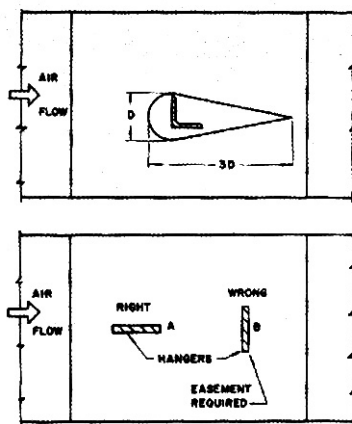
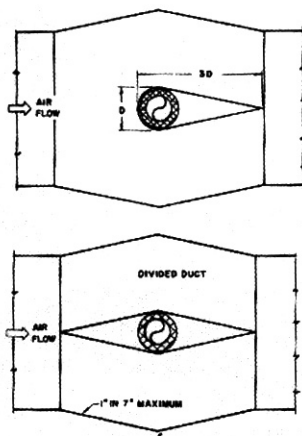

Fig. 24 – Easements Covering Irregular Shapes



NOTE: 1:7 slope is recommended for high velocity,
1:4 slope for low velocity.

Fig. 25 – Duct Transformed For Easements

3. If the easement exceeds 20% of the duct area, the duct is transformed or split into two ducts. When the duct is split or transformed, the original area should be maintained. *Fig. 25* illustrates a duct transformed and a duct split to accommodate the easement. In the second case, the split duct acts as the easement. When the duct is split or transformed, slope recommendations for transformations should be followed.
4. If an obstruction restricts only the corner of the duct, that part of the duct is transformed to avoid the obstruction. The reduction in duct area must not exceed 20% of the original area.

Elbows

A variety of elbows is available for round and rectangular duct systems. The following list gives the more common elbows:

Rectangular Duct

1. Full radius elbow
2. Short radius vaned elbow
3. Vaned square elbow

Round Duct

1. Smooth elbow
2. 3-piece elbow
3. 5-piece elbow

The elbows are listed in order of minimum cost. This sequence does not necessarily indicate the minimum pressure drop thru the elbow. *Table 9 thru 12* show the losses for the various rectangular and round elbows.

Full radius elbows (*Fig.26*) are constructed with an throat radius equal to $\frac{3}{4}$ of the duct dimension in the direction of the turn. An elbow having this throat radius has an R/D ratio of 1.25. This is considered to be an optimum ratio.

The short radius vaned elbow is shown in *Fig. 27*. This elbow can have one, two or three turning vanes. The vanes extend the full curvature of the elbow and their location is determined from *Chart 6*. *Example 2* illustrates the use of *Chart 6* in determining the location of the vanes in the elbow in *Fig. 28*.

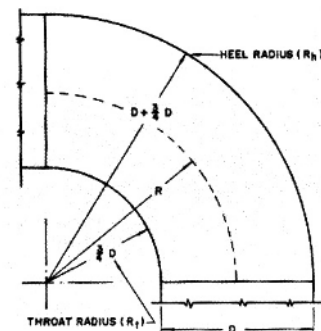

Fig. 26 – Full Radius Rectangular Elbow

Example 2 — Locating Vanes in a Rectangular Elbow

Given:

- Rectangular elbow shown in Fig. 28.
- Throat radius (R_t) – 3 in.
- Duct dimension in direction of turn–20 in.
- Heel radius (R_h) – 23 in.

Find:

1. Spacing for two vanes.
2. R/D ratio of elbow.

Solution:

1. Enter Chart 6 at $R_t = 3$ in. and $R_h = 23$ in. Read vane spacing for R_1 and R_2 (dotted line on chart).
 $R_1 = 6$ in. $R_2 = 12$ in.
2. The centerline radius R of the elbow equals 13 in. Therefore $R/D = 13/20 = 0.65$.

Although a throat radius is recommended, there may be instances in which a square corner is imperative. Chart 6 can still be used to locate the vanes. A throat radius is assumed to equal one-tenth of the heel radius. Example 3 illustrates vane location in an elbow with a square throat.

Example 3 — Locating Vanes in a Rectangular Elbow with a Square Throat

Given:

- Elbow shown in Fig. 29.
- Throat radius — none
- Heel radius — 20 in.
- Duct dimension in direction of turn-20 in.

Find:

Vane spacing

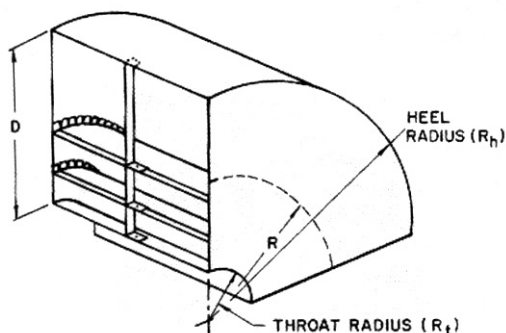

Fig. 27 – Short Radius Vaned Elbow

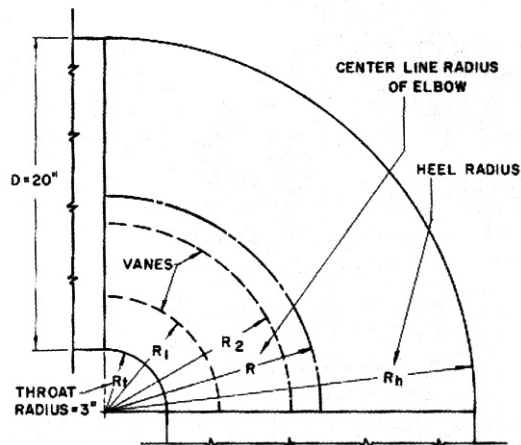

Fig. 28 – Rectangular Elbow Vane Location

Solution:

- Assume a throat radius equal to 0.1 of the heel radius:
 $.1 \times 20 = 2$ in.
- Enter Chart 63 at $R_t = 2$, and $R_h = 20$ in. Read vane spacing for R_1 and R_2 .
 $R_1 = 4.5$ in. $R_2 = 9.5$ in.

In addition a third vane is located at 2 in. which is the assumed throat radius.

A vaned square elbow has either double or single thickness closely spaced vanes. Fig. 30 illustrates double thickness vanes in a square elbow. These elbows are used where space limitation prevents the use of curved elbows and where square corner elbows are required.

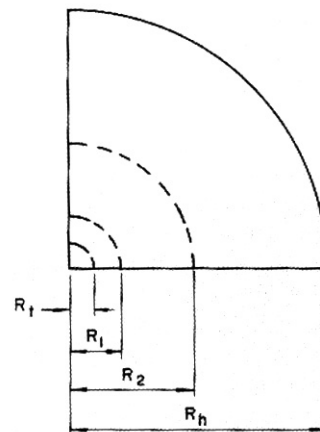
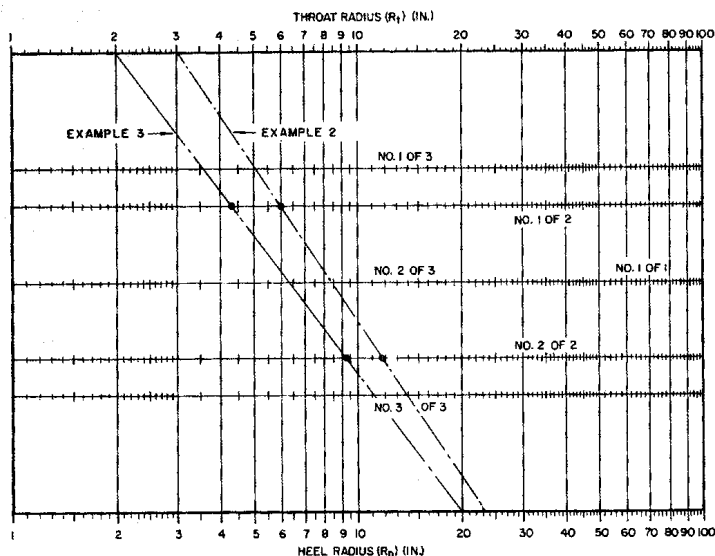

Fig. 29 – Rectangular Elbow With No Throat Radius

CHART 6 – VANE LOCATION FOR RECTANGULAR ELBOW



From Fan Engineering, Buffalo Forge Co.

The vaned square elbow is expensive to construct and usually has a higher pressure drop than the vaned short radius elbow and the standard elbow ($R/D = 1.25$).

Smooth elbows are recommended for round or *Spira-Pipe* systems. Fig. 31 illustrates a 90° smooth elbow with a R/D ratio of 1.5. This R/D ratio is standard for all elbows used with round or *Spira-Pipe* duct.

A 3-piece elbow (Fig.32) has the same R/D ratio as a smooth elbow but has the highest pressure drop of either the smooth or 5-piece elbow (Fig. 33). This elbow is second in construction costs and should be used when smooth elbows are unavailable.

The 5-piece elbow (Fig.33) has the highest first cost of all three types. It is used only when it is necessary to reduce the pressure drop below that of the 3-piece elbow, and when smooth elbows are not available.

A 45° elbow is either smooth (Fig. 34) or 3-piece (Fig. 35). A smooth 45° elbow is lower in first cost and pressure drop than the 3-piece 45° elbow. A 3-piece elbow is used when smooth elbows are not available.

Take-offs

There are several types of take-offs commonly used in rectangular duct systems. The recommendations given for rectangular elbows apply to take-offs. Fig.36 illustrates the more common take-offs. Fig. 36A is a take-off using a full radius elbow. In Figs. 36A and 36B the heel and throat radii originate from two different points

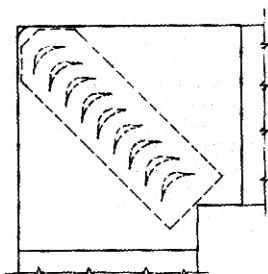

Fig. 30 – Vaned Square Elbow

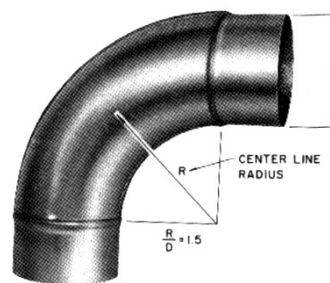

Fig. 31 - 90° Smooth Elbow

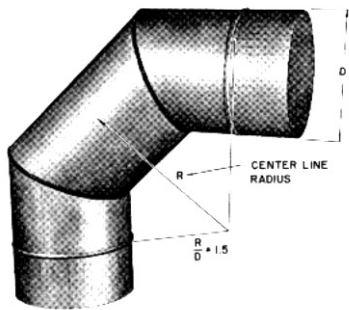

Fig. 32 - 90° 3-piece Elbow

since D is larger than D_1 . The principal difference in Figs. 36A and 36B is that the take-off extends into the duct in Fig. 36B and there is no reduction in the main duct.

Figure 36C illustrates a tap-in take-off with no part of the take-off extending into the duct. This type is often used when the quantity of air to be taken into the branch is small. The square elbow take-off (Fig. 36D) is the least desirable from a cost and pressure drop standpoint. It is limited in application to the condition in which space limitation prevents the use of a full radius elbow take-off.

A straight take-off (Fig. 37) is seldom used for duct branches. Its use is quite common, however, when a branch has only one outlet. In this instance it is called a collar. A splitter damper can be added for better control of the air to the take-off.

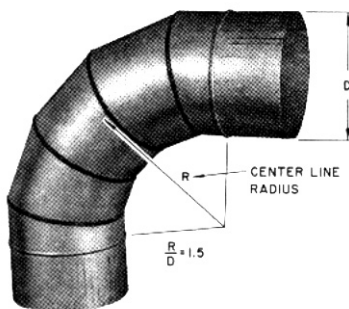

Fig. 33 - 90° 5-piece Elbow



Fig. 34 - 45° Smooth Elbow

There are two varieties of take-offs for round and Spira-Pipe duct systems: the 90° tee (Fig. 38) and the 90° conical tee (Fig. 39). A 90° conical tee is used when the air velocity in the branch exceeds 4000 fpm or when a smaller pressure drop than the straight take-off is required. Crosses with the take-offs located at 180°, 135° and 90° to each other are shown in Fig. 40.

When the duct system is designed, it may be necessary to reduce the duct size at certain take-offs. The reduction may be accomplished at the take-off (Fig. 41) or immediately after the take-off (Fig. 42). Reduction at the take-off is recommended since it eliminates one fitting.

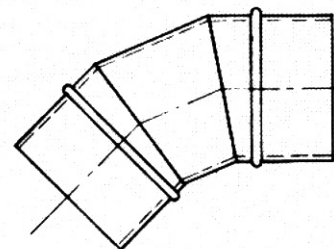

Fig. 35 - 45° 3-piece Elbow

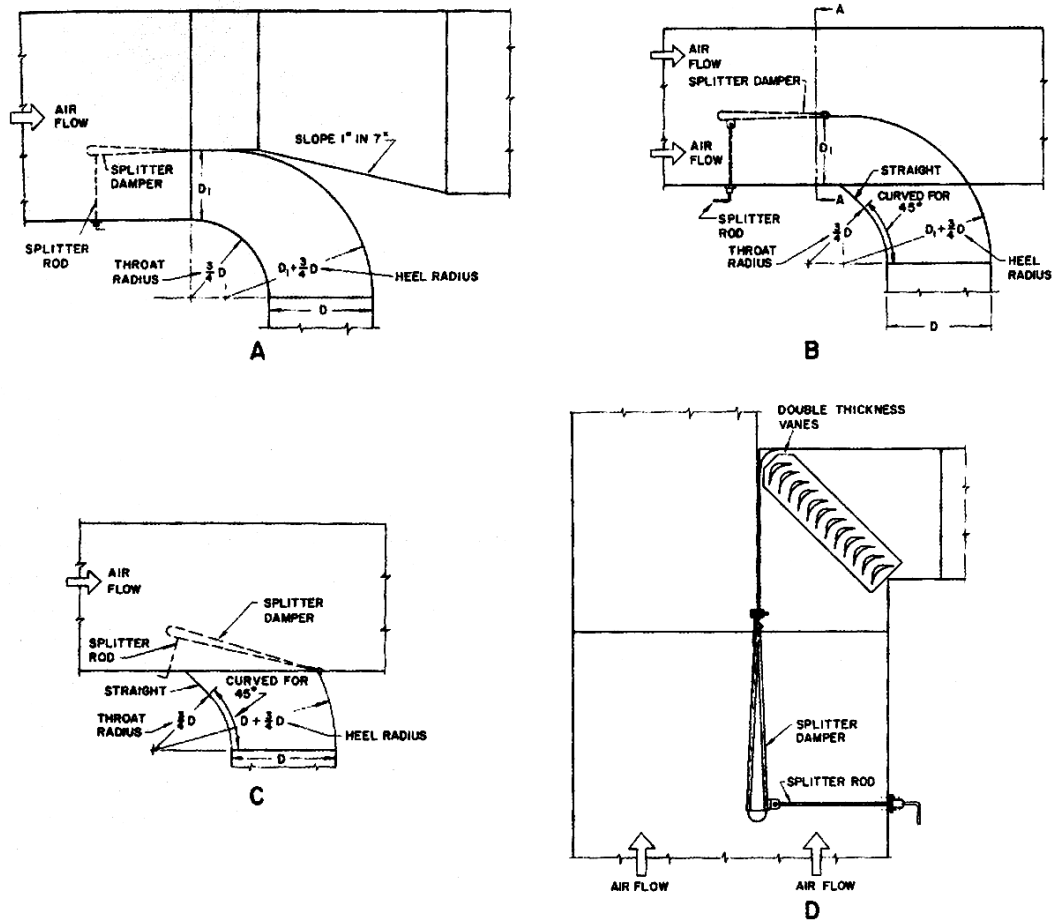

Fig. 36 – Typical Take-offs

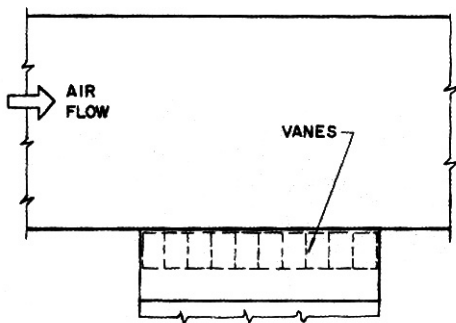

Fig. 37 – Outlet Collar

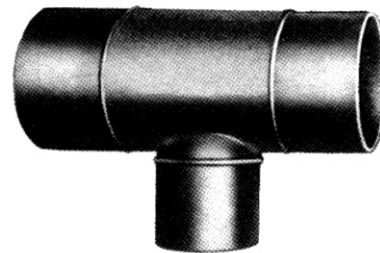

Fig. 38 - 90° Tee

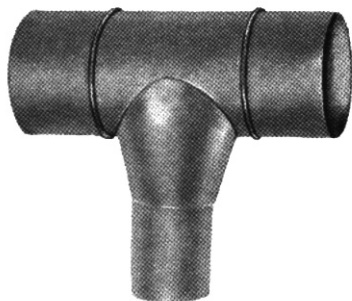
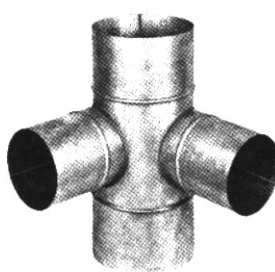
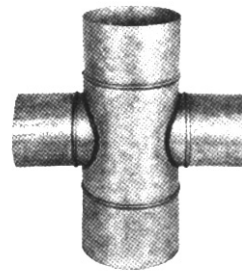

Fig. 39 – 90° CONICAL TEE



90°



180°

Fig. 40 - Crosses

TABLE 4 – MAXIMUM DIFFERENCE BETWEEN SUPPLY AIR TEMPERATURE AND ROOM DEWPOINT WITHOUT CONDENSING MOISTURE ON DUCTS (F)

AIR CONDITIONS SURROUNDING DUCT		AIR VELOCITY IN STRAIGHT RUN OF DUCT (FPM)*											
		Painted	Bright Metal	Painted	Bright Metal	Painted	Bright Metal	Painted	Bright Metal	Painted	Bright Metal	Painted	Bright Metal
DB (F)	RH (%)	400		800		1200		1600		2000		3000	
74 - 100	45	20	15	15	9	11	8	8	5	7	4	5	3
	50	18	13	13	8	10	7	7	5	6	4	4	3
	55	15	11	11	7	8	6	6	4	5	3	4	2
	60	13	10	10	6	7	5	5	3	4	3	3	2
	70	9	7	7	4	5	4	4	2	3	2	2	2
	80	6	4	4	3	3	2	2	2	2	1	2	1
	85	4	3	3	2	2	2	2	1	2	1	1	1
VALUE OF $\frac{f_2}{U} - 1$.90	.66	.66	.42	.49	.31	.37	.24	.31	.20	.23	.15

*For elbows and other fittings, see Notes 4 and 7.

EQUATION: $t_{dp} - t_{sa} = (t_{rm} - t_{dp}) \left(\frac{f_2}{U} - 1 \right)$

where: t_{dp} = duct surface temp, assumed equal to room dewpoint.
 t_{sa} = supply air dry-bulb temp in duct.
 t_{rm} = room dry-bulb temp.

U = overall heat transmission coefficient of duct
 Btu/(hr) (sq ft) (deg F)

f_2 = film heat transmission coefficient on outside of duct, Btu/(hr) (sq ft) (deg F) = 1.65 for painted ducts and 1.05 for bright metal ducts.

NOTES:

1. Exceptional Cases: Condensation will occur at a lower relative humidity than indicated in the table when f_2 falls below the average value of 1.65 for painted ducts and 1.05 for bright metal ducts. The radiation component of f_2 will decrease when the duct is exposed to surfaces colder than the room air, as near a cold wall. The convection component will decrease for the top of ducts, and also where the air flow is obstructed, such as a duct running very close to a partition. If either condition exists, use value given for a relative humidity 5% less than the relative humidity in the room. If both conditions exist, use value given for 10% lower relative humidity.
2. Source: Calculated using film heat transmission coefficient on inside of duct ranging from 1.5 to 7.2 Btu/(hr) (Sq ft) (deg F). The above equation is based on the principle that the temperature drop through any layer is directly proportional to its thermal resistance. It is assumed that the air movement surrounding the outside of the duct does not exceed approximately 50 fpm.
3. For Room Conditions Not Given: Use the above equation and the values of $f_2/U - 1$ shown at the bottom of the table.
4. Application: Use for bare ducts, not furred or insulated. Use the values for bright metal ducts for both unpainted aluminum and unpainted galvanized ducts. Condensation at elbows,

transformations and other fittings will occur at a higher supply air temperature because of the higher inside film heat transmission coefficient due to the air impinging against the elbow or fitting. For low velocity fittings, assume an equivalent velocity of two times the straight run velocity and use the above table. For higher velocity fittings where straight run velocity is 1500 fpm and above, keep the supply air temperature no more than one degree lower than the room dewpoint. Transformations having a slope less than one in six may be considered as a straight run.

5. Bypass Factor and Fan Heat: The air leaving the dehumidifier will be higher than the apparatus dewpoint temperature when the bypass factor is greater than zero. Treat this as a mixture problem. Whenever the fan is on the leaving side of the dehumidifier, the supply air temperature is usually at least one to four degrees higher than the air leaving the dehumidifier, and can be calculated using the fan brake horsepower.
6. Dripping: Condensation will generally not be severe enough to cause dripping unless the surface temperature is two to three degree

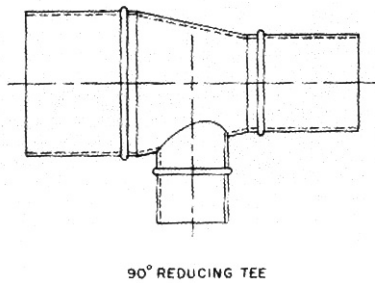

Fig. 41 – Reducing Duct Size At Take-off

below the room dewpoint. Note that the table is based on the duct surface temperature equal to the room dewpoint in estimating the possibility of dripping. It is recommended that the surface temperature be kept above the room dewpoint.

7. Elimination of Condensation: The supply air temperature must be high enough to prevent condensation at elbows and fittings. Occasionally, it might be desirable to insulate only the elbows or fittings. If moisture is expected to condense only at the fittings, apply insulation (1/2" thick usually sufficient) either to the inside or outside of duct at the fitting and for a distance downstream equal to 1.5 times the duct perimeter. If condensation occurs on a straight run, the thickness of insulation required can be found by solving the above equation for U.

Air Control

In low velocity air distribution systems the flow of air to the branch take-off is regulated by a splitter damper. The position of the splitter damper is adjusted by use of

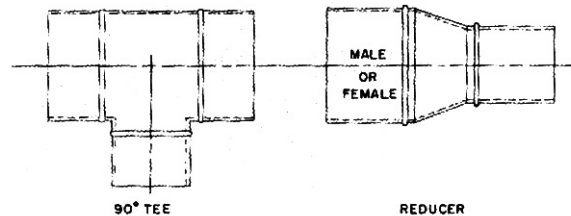

Fig. 42 – Reducing Duct Size After Take-off

the splitter rod. Splitter dampers for rectangular duct systems are illustrated in Fig.36. Pivot type dampers are sometimes installed in the branch line to control flow. When these are used, splitter dampers are omitted. Splitter dampers are preferred in low velocity systems, and pivot type or volume dampers are used in high velocity systems.

In high velocity systems, balancing or volume dampers are required at the air conditioning terminals to regulate the air quantity.

Duct Condensation

Ducts may "sweat" when the surface temperature of the duct is below the dewpoint of the surrounding air. Table 4 lists the maximum difference between supply air temperature and room dewpoint without condensing moisture on the duct for various duct velocities. See the notes below the table for application of the data contained in the table. Table 5 lists various U factors for

TABLE 5—DUCT HEAT TRANSMISSION COEFFICIENTS

TYPE DUCT INSULATION	FINISH	TOTAL THICKNESS (in.)	WEIGHT (lb/sq ft)	K*	U†
Uninsulated Sheet Metal	None	—	—	—	1.14‡
	Metal lath and plaster—3/4"	—	—	—	.99
	Wood lath and plaster—3/4"	—	—	—	.79
Corkboard	None	1	0.7	.28	.22
	None	2	1.4	—	.12
	Plaster—3/8"	1	2.2	.28	.22
	Plaster—3/8"	2	2.9	—	.12
Corrugated Asbestos Paper (air cell)	None	1	0.73	.50	.34
	None	2	1.46	—	.20
Rock Cork	None	1	1.35	.35	.23
	None	2	2.7	—	.13
	Plaster—3/8"	1	2.9	.35	.23
	Plaster—3/8"	2	4.2	—	.13
Mineral Wool Blanket	None	1	1.17	.28	.22
	None	2	2.35	—	.12
Glass Fiber	None	1	.08	.27	.21
	None	2	.17	—	.10
85% Magnesia	None	1	1.0	.39	.26

*Conductivity of insulating material only (per in.)

†Overall U for still air outside duct and 1200 fpm inside duct.

‡Uninsulated Bare Duct.

Air Velocity (fpm)	400	800	1200	1600	2000
Overall U	.98	1.08	1.14	1.19	1.22

common insulating material. It can be used in conjunction with *Table 4* to determine required insulation to eliminate condensation.

DUCT SYSTEM ACCESSORIES

Fire dampers, access doors and sound absorbers are accessories which may be required in a duct system but do not materially affect the design, unless there are several dampers in series. For this arrangement, the additional resistance to air flow must be recognized when selecting the fan.

Fire Dampers

Normally local or state codes dictate the use, location and construction of fire dampers for an air distribution system. The National Board of Fire Underwriters describes the general construction and installation practices in pamphlet NBFU 90A.

There are two principal types of fire dampers used in rectangular ductwork:

1. The rectangular pivot damper (*Fig.43*) which may be used in either the vertical or horizontal position.
2. The rectangular louver fire damper which may be used only in the horizontal position (*Fig.44*).

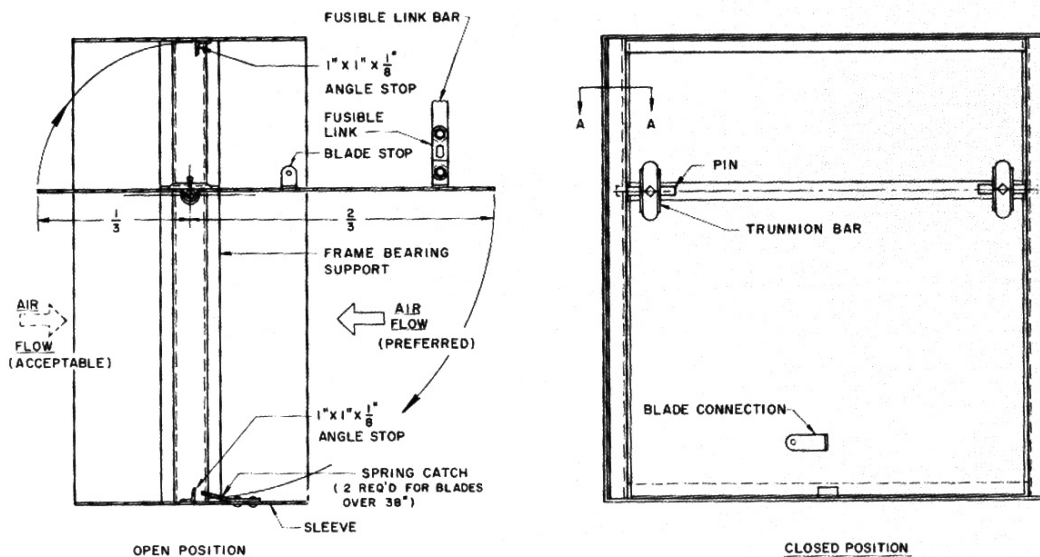

MATERIAL SPECIFICATIONS

Maximum Over-all Height	30"
Maximum Over-all Width	50"
Minimum Sleeve Length	11 3/4"
Sleeve	10 U. S. gage steel
Blade - Up to 18"	16 U. S. gage steel
18 1/4" - 36"	12 U. S. gage steel
36 1/4" and over	7 U. S. gage steel
Frame Bearing Support	3" x 7/8" x 1/8" hat channel
Trunnion Bar	Die cast steel
Spring Catch	0.040" bronze spring stock

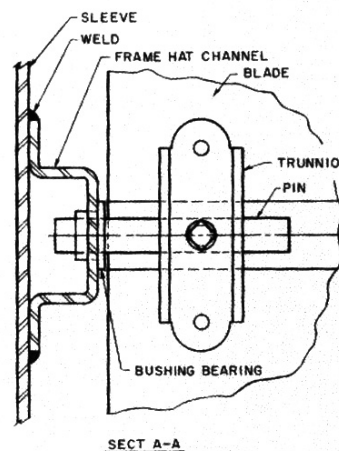

Fig. 43 – Rectangular Pivot Fire Damper

Figure 45 illustrates a pivot fire damper for round duct systems. This damper may be used in either the horizontal or vertical position.

Access Doors

Access doors or access panels are required in duct systems before and after equipment installed in ducts. Access panels are also required for access to fusible links in fire dampers.

DUCT DESIGN

This section presents the necessary data for designing low and high velocity duct systems. This data includes the standard air friction charts, recommended design velocities, losses thru elbows and fittings, and the common methods of designing the air distribution systems. Information is given also for evaluating the effects of duct heat gain and altitude on system design.

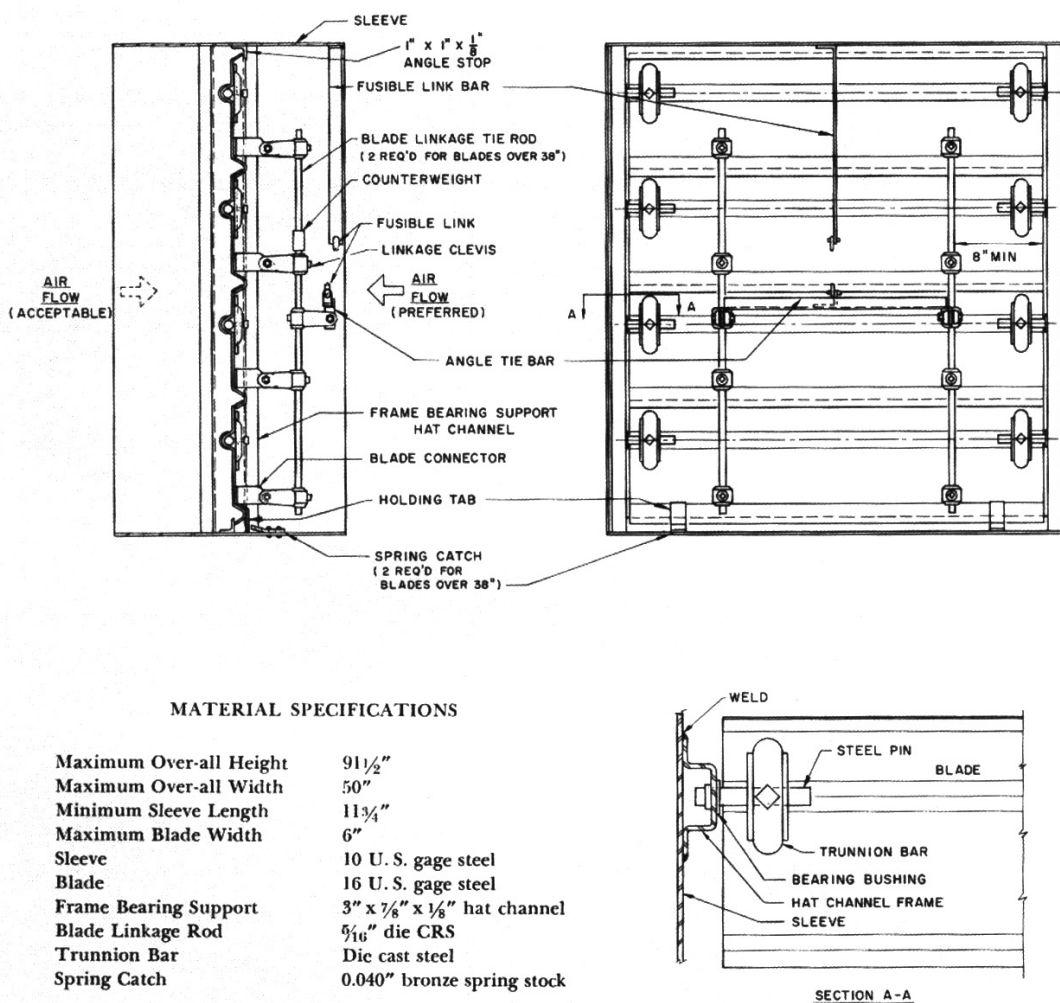

Fig. 44 – Rectangular Louver Fire Damper

Friction Chart

In any duct section thru which air is flowing, there is a continuous loss of pressure. This loss is called duct friction loss and depends on the following:

1. Air velocity
2. Duct size
3. Interior surface roughness
4. Duct length

Varying any one of these four factors influences the friction loss in the ductwork. The relationship of these

factors is illustrated in the following equation:

$$\Delta P = 0.03 f \left(\frac{L}{d^{2.2}} \right) \left(\frac{V}{1000} \right)^{1.82}$$

- where: ΔP = friction loss (in. wg)
 f = interior surface roughness
 (0.9 for galvanized duct)
 L = length of duct (ft)
 d = duct diameter (in.), equivalent diam.
 for rectangular ductwork
 V = air velocity (fpm)

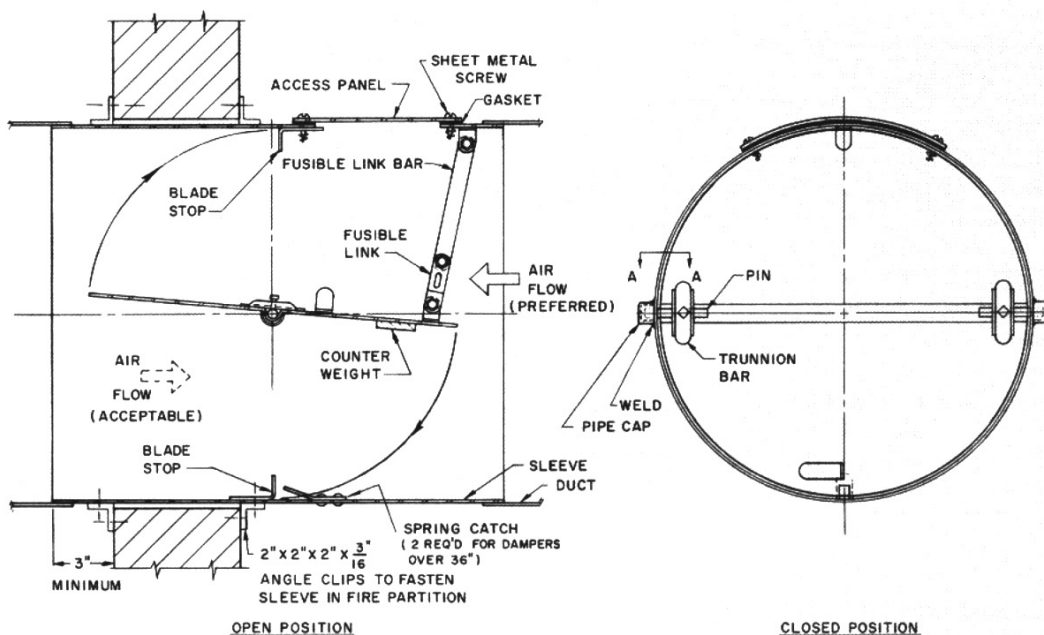

MATERIAL SPECIFICATIONS

Maximum Diameter	48"
Minimum Sleeve Length	15½" plus wall thickness*
Sleeve	10 U. S. gage steel
Blade – Up to 18"	16 U. S. gage steel
18½" to 36"	12 U. S. gage steel
36½" and over†	7 U. S. gage steel
Trunnion Bar	Die cast steel
Spring Catch	0.040" bronze spring stock

*Access panel in sleeve. Length 8" plus wall thickness when access panel is in duct.

†Requires ¾" x ¾" x 1/8" angle blade stiffener.

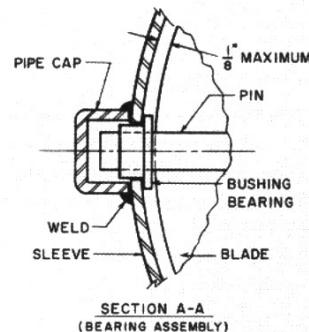

Fig. 45 – Round Pivot Fire Damper

This equation is used to construct the standard friction chart (*Chart 7*) based on galvanized duct and air at 70 F and 29.92 in. Hg. This chart may be used for systems handling air from 30° to 120 F and for altitudes up to 2000 ft without correcting the air density. *Page 59* contains the data for designing high altitude air distribution systems.

Air Quantity

The total supply air quantity and the quantity required for each space is determined from the air conditioning load estimate in *Part 1*.

Duct Diameter

Table 6 gives the rectangular duct size for the various equivalent duct diameters shown on *Chart 7*. Next to the diameter is the cross-section area of the round duct. The rectangular ducts shown for this cross-section area handle the same air quantity at the same friction rate as the equivalent round duct listed. Therefore, this cross-section area is less than the actual cross-section area of the rectangular duct determined by multiplying the duct dimensions. In selecting the rectangular duct sizes from *Table 6*, the duct diameter from the friction chart or the duct area as determined from the air quantity and velocity may be used.

However, rectangular duct sizes should not be determined directly from the duct area without using *Table 6*. If this is done, the resulting duct sizes will be smaller, and velocity and friction loss will be greater, for a given air quantity than the design values.

Air Velocity

The Design velocity for an air distribution system depends primarily on sound level requirements, first cost and operating cost.

Table 7 lists the recommended velocities for supply and return ducts in a low velocity system. These velocities are based on experience.

In high velocity systems, the supply ducts are normally limited to a maximum duct velocity of 5000 fpm. Above this velocity, the sound level may become objectionable and the operating cost (friction rate) may become excessive. Selecting the duct velocity, therefore, is a question of economics. A very high velocity results in smaller ducts and lower duct material cost but it requires a higher operating cost and possibly a larger fan motor and a higher class fan. If a lower duct velocity is used, the ducts must be larger but the operating cost decreases and the fan motor and fan class may be smaller.

The return ducts for a high velocity supply system have the same design velocity recommendations as listed

in *Table 7* for a low velocity system, unless extensive sound treatment is provided to use higher velocities.

Friction Rate

The friction rate on the friction chart is given in terms of inches of water per 100 ft of equivalent length of duct. To determine the loss in any section of ductwork, the total equivalent length in that section is multiplied by the friction rate which gives the friction loss. The total equivalent length of duct includes all elbows and fittings that may be in the duct section. *Table 9 thru 12* are used to evaluate the losses thru various duct system elements in terms of equivalent length. The duct sections including these elements are measured to the centerline of the elbows in the duct section as illustrated in *Fig.46*. The fittings are measured as part of the duct section having the largest single dimension.

Velocity Pressure

The friction chart shows a velocity pressure conversion line. The velocity pressure may be obtained by reading vertically upward from the intersection of the conversion line and the desired velocity. *Table 8* contains velocity pressure for the corresponding velocity.

Flexible Metal Conduit

Flexible metal conduit is often used to transmit the air from the riser or branch headers to the air conditioning terminal in a high velocity system. The friction loss thru this conduit is higher than thru round duct. *Chart 8* gives the friction rate for 3 and 4 in. flexible metal conduit.

(Continued on next 5 pages)

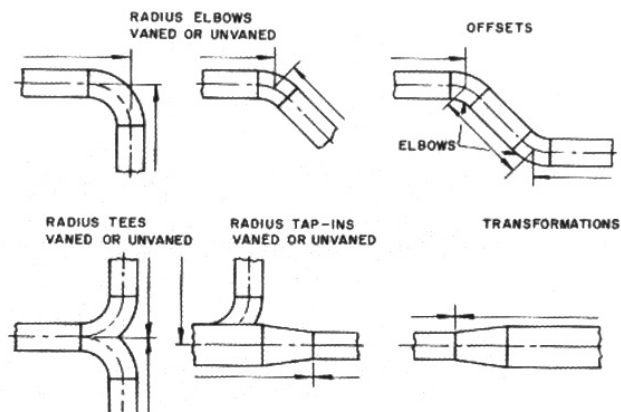

NOTE: All measurements are center line. Fittings are measured as part of the duct having largest single dimension.

Fig. 46 – Guide For Measuring Duct Lengths

CHART 7 – FRECTION LOSS FOR ROUND DUCT

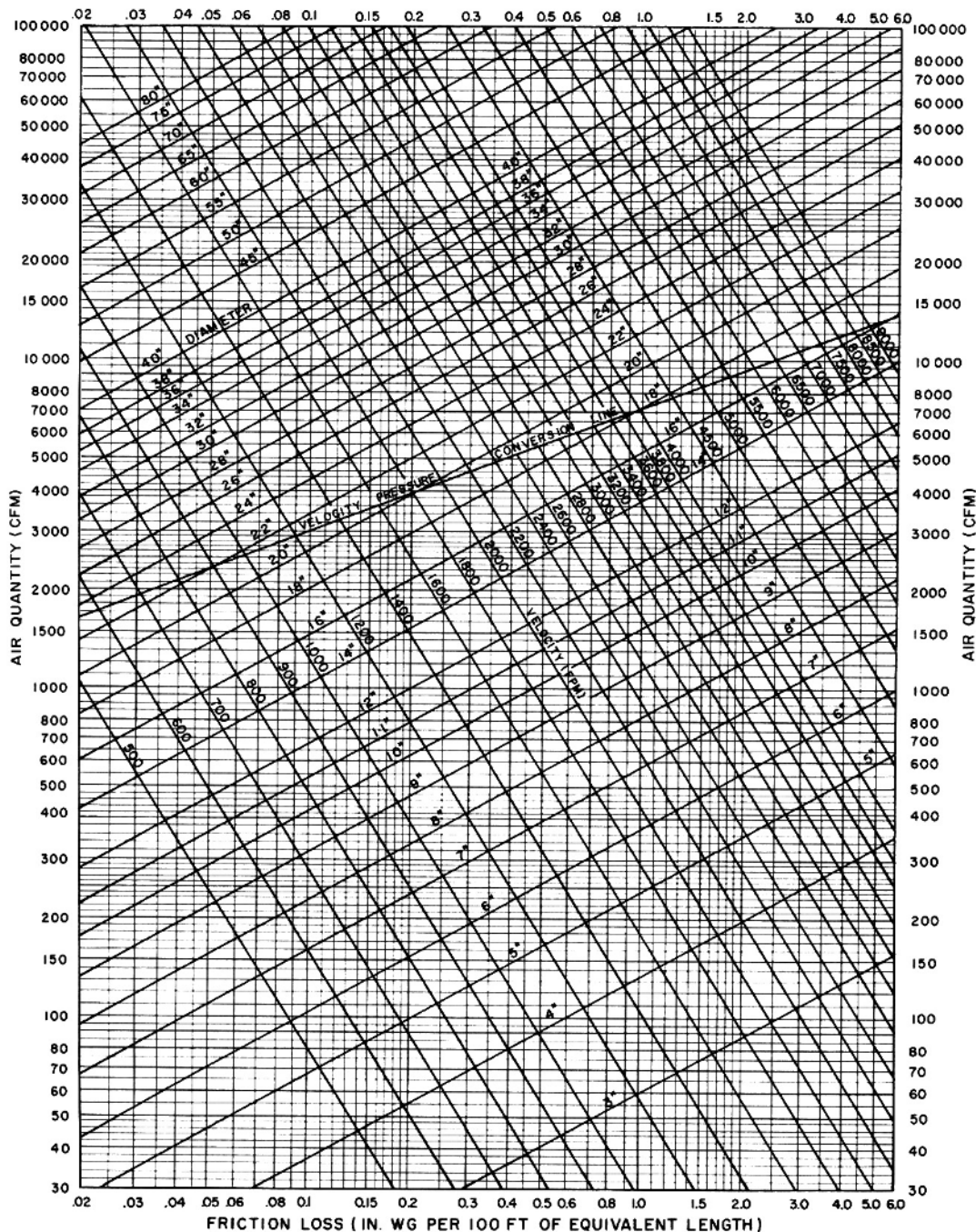

TABLE 6 – CIRCULAR EQUIVALENT DIAMETER,*EQUIVALENT AREA AND DUCT CLASS † OF RECTANGULAR DUCTS FOR EQUAL FRICTION.

SIDE	6		8		10		12		14		16		18		20		22		
	Area sq ft	Diam in.	Area sq ft	Diam in.	Area sq ft	Diam in.	Area sq ft	Diam in.	Area sq ft	Diam in.	Area sq ft	Diam in.	Area sq ft	Diam in.	Area sq ft	Diam in.	Area sq ft	Diam in.	
10	.39	8.4	.52	9.8	.65	10.9													
12	.45	9.1	.62	10.7	.77	11.9	.94	13.1											
14	.52	9.8	.72	11.5	.91	12.9	1.09	14.2	1.28	15.3									
16	.59	10.4	.81	12.2	1.02	13.7	1.24	15.1	1.45	16.3	1.67	17.5							
18	.66	11.0	.91	12.9	1.15	14.5	1.40	16.0	1.63	17.3	1.87	18.5	2.12	19.7					
20	.72	11.5	.99	13.5	1.26	15.2	1.54	16.8	1.81	18.2	2.07	19.5	2.34	20.7	2.61	21.9			
22	.78	12.0	1.08	14.1	1.38	15.9	1.69	17.6	1.99	19.1	2.27	20.4	2.57	21.7	2.86	22.9	3.17	24.1	
24	.84	12.4	1.16	14.6	1.50	16.6	1.83	18.3	2.14	19.8	2.47	21.3	2.78	22.6	3.11	23.9	3.43	25.1	
26	.89	12.8	1.26	15.2	1.61	17.2	1.97	19.0	2.31	20.6	2.66	22.1	3.01	23.5	3.35	24.8	3.71	26.1	
28	.95	13.2	1.33	15.6	1.71	17.7	2.09	19.6	2.47	21.3	2.86	22.9	3.25	24.4	3.60	25.7	4.00	27.1	
30	1.01	13.6	1.41	16.1	1.82	18.3	2.22	20.2	2.64	22.0	3.06	23.7	3.46	25.2	3.89	26.7	4.27	28.0	
32	1.07	14.0	1.48	16.5	1.93	18.8	2.36	20.8	2.81	22.7	3.25	24.4	3.68	26.0	4.12	27.5	4.55	28.9	
34	1.13	14.4	1.58	17.0	2.03	19.3	2.49	21.4	2.96	23.3	3.43	25.1	3.89	26.7	4.37	28.3	4.81	29.7	
36	1.18	14.7	1.65	17.4	2.14	19.8	2.61	21.9	3.11	23.9	3.63	25.8	4.09	27.4	4.58	29.0	5.07	30.5	
38	1.23	15.0	1.73	17.8	2.25	20.3	2.76	22.5	3.27	24.5	3.80	26.4	4.30	28.1	4.84	29.8	5.37	31.4	
40	1.28	15.3	1.81	18.2	2.33	20.7	2.88	23.0	3.43	25.1	3.97	27.0	4.52	28.8	5.07	30.5	5.62	32.1	
42	1.33	15.6	1.86	18.5	2.43	21.1	2.98	23.4	3.57	25.6	4.15	27.6	4.71	29.4	5.31	31.2	5.86	32.8	
44	1.38	15.9	1.95	18.9	2.52	21.5	3.11	23.9	3.71	26.1	4.33	28.2	4.90	30.0	5.55	31.9	6.12	33.5	
46	1.43	16.2	2.01	19.2	2.61	21.9	3.22	24.3	3.88	26.7	4.49	28.7	5.10	30.6	5.76	32.5	6.37	34.2	
48	1.48	16.5	2.09	19.6	2.71	22.3	3.35	24.8	4.03	27.2	4.65	29.2	5.30	31.2	5.97	33.1	6.64	34.9	
50			2.16	19.9	2.81	22.7	3.46	25.2	4.15	27.6	4.84	29.8	5.51	31.8	6.19	33.7	6.87	35.5	
52			2.22	20.2	2.91	23.1	3.57	25.6	4.30	28.1	5.00	30.3	5.72	32.4	6.41	34.3	7.14	36.0	
54			2.29	20.5	2.98	23.4	3.71	26.1	4.43	28.5	5.17	30.8	5.90	32.9	6.64	34.9	7.38	36.8	
56			2.38	20.9	3.09	23.8	3.83	26.5	4.55	28.9	5.31	31.2	6.08	33.4	6.87	35.5	7.62	37.4	
58			2.43	21.1	3.19	24.2	3.94	26.9	4.68	29.3	5.48	31.7	6.26	33.9	7.06	36.0	7.87	38.0	
60			2.50	21.4	3.27	24.5	4.06	27.3	4.84	29.8	5.65	32.2	6.50	34.5	7.26	36.5	8.12	38.6	
64			2.64	22.0	3.46	25.2	4.24	27.9	5.10	30.6	5.91	33.1	6.87	35.5	7.71	37.6	8.59	39.7	
68					3.63	25.8	4.49	28.7	5.37	31.4	6.26	33.9	7.18	36.3	8.12	38.6	9.03	40.7	
72					3.83	26.5	4.71	29.4	5.69	32.3	6.60	34.8	7.54	37.2	8.50	39.5	9.52	41.8	
76					4.09	27.4	4.91	30.0	5.86	32.8	6.83	35.4	7.95	38.2	8.90	40.4	9.98	42.8	
80					4.15	27.6		5.17	30.8	6.15	33.6	7.22	36.4	8.29	39.0	9.21	41.1	10.4	43.8
84							5.41	31.5	6.41	34.5	7.54	37.2	8.55	39.6	9.75	42.3	10.8	44.6	
88							5.58	32.0	6.64	34.9	7.87	38.0	8.94	40.5	10.1	43.1	11.2	45.4	
92							5.79	32.6	6.91	35.6	8.12	38.6	9.39	41.5	10.4	43.8	11.7	46.3	
96							5.90	33.0	7.14	36.2	8.40	39.2	9.70	42.1	10.8	44.5	12.1	47.2	
100								7.40	36.9	8.50	39.5	9.80	42.5	11.3	45.5	12.3	47.6		
104								7.60	37.4	8.90	40.5	10.3	43.5	11.6	46.2	13.0	48.8		
108								7.90	38.0	9.20	41.2	10.6	44.0	12.0	47.0	13.4	49.6		
112								8.10	38.6	9.50	41.8	10.9	44.7	12.3	47.5	13.8	50.3		
116										9.80	42.4	11.3	45.5	12.6	48.1	14.3	51.3		
120										10.0	42.8	11.5	46.0	13.1	49.1	14.4	51.5		
124										10.3	43.5	11.9	46.7	13.4	49.6	15.0	52.4		
128										10.6	44.1	12.1	47.1	13.8	50.4	15.5	53.3		
132												12.5	47.9	14.1	50.9	15.8	53.9		
136												12.8	48.5	14.5	51.6	16.2	54.5		
140												13.0	48.8	14.7	52.0	16.5	55.0		
144												13.3	49.4	15.2	52.9	16.8	55.6		

*Circular equivalent diameter (d_c). Calculated from $d_c = 1.3 \frac{(ab)^{0.25}}{(a+b)^{0.25}}$

†Large numbers in table are duct class.

TABLE 6 – CIRCULAR EQUIVALENT DIAMETER,*EQUIVALENT AREA AND DUCT CLASS †
OF RECTANGULAR DUCT FOR EQUAL FRICTION. (Cont.)

SIDE	24		26		28		30		32		34		36		38		40	
	Area sq ft	Diam in.	Area sq ft	Diam in.	Area sq ft	Diam in.	Area sq ft	Diam in.	Area sq ft	Diam in.	Area sq ft	Diam in.	Area sq ft	Diam in.	Area sq ft	Diam in.	Area sq ft	Diam in.
10																		
12																		
14																		
16																		
18																		
20																		
22																		
24	3.74	26.2																
26	4.03	27.2	4.40	28.4														
28	4.33	28.2	4.74	29.5	5.10	30.6												
30	4.68	29.3	5.07	30.5	5.44	31.6	5.86	32.8										
32	4.94	30.1	5.37	31.4	5.79	32.6	6.23	33.8	6.68	35.0								
34	5.24	31.0	5.69	32.3	6.15	33.6	6.60	34.8	7.06	36.0	7.54	37.2						
36	5.58	32.0	5.94	33.0	6.52	34.6	6.99	35.8	7.46	37.0	7.95	38.2	8.46	39.4				
38	5.86	32.8	6.38	34.2	6.87	35.5	7.34	36.7	7.87	38.0	8.37	39.2	8.89	40.4	9.43	41.6		
40	6.15	33.6	6.71	35.1	7.22	36.4	7.71	37.6	8.29	39.0	8.81	40.2	9.34	41.4	9.89	42.6	10.5	43.8
42	6.45	34.4	7.03	35.9	7.58	37.3	8.12	38.6	8.68	39.9	9.21	41.1	9.80	42.4	10.4	43.6	11.0	44.8
44	6.75	35.2	7.34	36.7	7.91	38.1	8.50	39.5	9.07	40.8	9.61	42.0	10.3	43.4	10.8	44.6	11.4	45.8
46	7.03	35.9	7.63	37.4	8.25	38.9	8.85	40.3	9.48	41.7	10.1	43.0	10.7	44.3	11.3	45.6	11.9	46.8
48	7.30	36.6	7.95	38.2	8.59	39.7	9.25	41.2	9.89	42.6	10.5	43.9	11.1	45.2	11.8	46.5	12.4	47.8
50	7.58	37.3	8.25	38.9	8.90	40.4	9.61	42.0	10.3	43.5	10.9	44.8	11.6	46.1	12.2	47.4	13.0	48.8
52	7.87	38.0	8.55	39.6	9.25	41.2	9.98	42.8	10.7	44.3	11.4	45.7	12.1	47.1	12.7	48.3	13.5	49.7
54	8.16	38.7	8.85	40.3	9.61	42.0	10.4	43.6	11.0	45.0	11.8	46.5	12.6	48.0	13.2	49.2	14.0	50.6
56	8.42	39.3	9.16	41.0	9.94	42.7	10.7	44.3	11.4	45.8	12.2	47.3	13.0	48.8	13.7	50.1	14.5	51.5
58	8.63	39.8	9.48	41.7	10.3	43.4	11.0	45.0	11.8	46.6	12.6	48.1	13.4	49.6	14.2	51.0	15.0	52.4
60	8.89	40.4	9.75	42.3	10.5	44.0	11.4	45.8	12.2	47.3	13.0	48.9	13.8	50.4	14.6	51.8	15.5	53.3
64	9.43	41.6	10.3	43.5	11.2	45.4	12.1	47.2	12.9	48.7	13.8	50.4	14.7	52.0	15.5	53.4	16.5	55.0
68	9.98	42.8	10.9	44.7	11.8	46.6	12.8	48.4	13.7	50.2	14.6	51.8	15.6	53.5	16.5	55.0	17.5	56.6
72	10.4	43.8	11.5	45.9	12.4	47.8	13.5	49.7	14.4	51.5	15.4	53.2	16.4	54.9	17.4	56.5	18.3	58.0
76	10.8	44.9	12.0	47.0	13.1	49.0	14.1	50.8	15.1	52.7	16.2	54.6	17.3	56.3	18.3	57.9	19.3	59.5
80	11.5	46.0	12.6	48.0	13.7	50.1	14.7	52.0	15.8	53.9	17.0	55.8	18.1	57.6	19.2	59.3	20.3	61.0
84	12.0	46.9	13.2	49.2	14.2	51.1	15.4	53.2	16.5	55.0	17.7	57.0	18.9	58.9	20.1	60.7	21.2	62.4
88	12.5	47.9	13.7	50.1	14.8	52.2	16.1	54.3	17.3	56.3	18.5	58.2	19.7	60.1	20.9	62.0	22.1	63.7
92	12.9	48.7	14.2	51.1	15.5	53.4	16.7	55.4	18.0	57.4	19.2	59.4	20.5	61.3	21.8	63.2	23.0	65.0
96	13.3	49.5	14.8	52.2	15.9	54.0	17.2	56.2	18.6	58.5	19.7	60.2	21.1	62.2	22.7	64.5	24.0	66.3
100	13.9	50.6	15.0	52.5	16.7	55.3	17.9	57.3	19.2	59.4	20.6	61.5	21.6	63.0	23.4	65.5	24.8	67.5
104	14.6	51.8	15.8	53.9	17.1	56.0	18.6	58.5	19.9	60.5	21.4	62.6	22.7	64.5	24.1	66.5	25.6	68.5
108	14.8	52.1	16.2	54.6	17.6	56.8	19.2	59.4	20.5	61.4	22.0	63.5	23.5	65.7	24.8	67.5	26.5	69.7
112	15.1	52.7	16.8	55.5	18.3	58.0	19.7	60.1	21.1	62.3	22.5	64.3	24.5	67.0	25.7	68.7	27.1	70.5
116	15.8	53.9	17.3	56.4	18.9	58.9	20.3	61.1	22.0	63.6	23.5	65.7	24.8	67.5	26.2	69.4	28.2	71.9
120	16.2	54.6	17.8	57.1	19.4	59.6	20.9	62.0	22.7	64.5	24.2	66.7	26.1	69.2	27.2	70.6	29.0	73.0
124	16.6	55.2	18.4	58.1	19.8	60.3	21.6	63.0	23.2	65.4	25.2	68.0	26.5	69.8	28.2	71.9	29.8	74.0
128	17.1	56.0	18.8	58.8	20.3	61.1	22.3	64.0	23.7	66.0	25.6	68.6	27.3	70.8	28.7	72.6	30.2	74.5
132	17.4	56.5	19.3	59.5	20.8	61.8	22.6	64.4	24.5	67.0	26.3	69.5	28.2	72.0	29.8	74.0	32.0	76.6
136	17.9	57.3	19.7	60.2	21.4	62.7	23.0	65.0	25.1	67.9	26.9	70.3	28.7	72.6	30.5	74.8	32.6	77.3
140	18.5	58.2	20.3	61.0	22.3	64.0	24.1	66.5	25.9	69.0	27.5	71.1	29.4	73.5	31.5	76.0	33.4	78.3
144	18.8	58.7	20.6	61.5	22.7	64.5	24.8	67.5	26.3	69.5	28.2	72.0	29.9	74.1	32.0	76.6	34.0	79.0

*Circular equivalent diameter (d_c). Calculated from $d_c = 1.3 \sqrt{\frac{ab}{a+b}}$

†Large numbers in table are duct class.

TABLE 6 – CIRCULAR EQUIVALENT DIAMETER,*EQUIVALENT AREA AND DUCT CLASS † OF RECTANGULAR DUCTS FOR EQUAL FRICTION. (Cont.)

SIDE	42		44		46		48		50		52		54		56		58	
	Area sq ft	Diam in.	Area sq ft	Diam in.	Area sq ft	Diam in.	Area sq ft	Diam in.	Area sq ft	Diam in.	Area sq ft	Diam in.	Area sq ft	Diam in.	Area sq ft	Diam in.	Area sq ft	Diam in.
42	11.5	45.9																
44	12.0	46.9	12.6	48.1														
46	12.5	47.9	13.1	49.1	13.8	50.3												
48	13.0	48.9	13.7	50.2	14.3	51.3	15.1	52.6										
50	13.5	49.8	14.3	51.2	14.9	52.3	15.7	53.6	16.3	54.7								
52	14.1	50.8	14.8	52.2	15.5	53.3	16.2	54.6	17.0	55.8	17.6	56.9						
54	14.6	51.8	15.4	53.2	16.1	54.3	16.8	55.6	17.6	56.8	18.3	57.9	19.2	59.4				
56	15.1	52.7	15.9	54.1	16.7	55.3	17.4	56.5	18.2	57.8	18.9	58.9	19.6	60.0	20.5	61.3		
58	15.7	53.7	16.5	55.0	17.2	56.2	18.0	57.5	18.8	58.8	19.6	60.0	20.4	61.2	21.1	62.3	22.0	63.5
60	16.2	54.6	17.0	55.9	17.8	57.1	18.6	58.5	19.5	59.8	20.3	61.0	21.1	62.2	21.8	63.3	22.5	64.3
64	17.3	56.4	18.1	57.7	19.0	59.0	19.8	60.3	20.7	61.6	21.6	62.9	22.4	64.1	23.2	65.3	24.4	66.9
68	18.3	58.0	19.3	59.5	20.1	60.8	21.1	62.1	21.9	63.4	22.9	64.8	23.8	66.1	24.7	67.3	25.5	68.4
72	19.4	59.6	20.3	61.1	21.4	62.6	22.2	63.9	23.1	65.2	24.2	66.6	25.1	67.9	26.1	69.2	27.1	70.5
76	20.4	61.2	21.4	62.7	22.4	64.1	23.4	65.6	24.5	67.0	25.5	68.4	26.4	69.6	27.5	71.0	28.9	72.8
80	21.4	62.7	22.4	64.1	23.5	65.7	24.6	67.2	25.7	68.7	26.8	70.1	28.1	71.8	28.8	72.7	30.1	74.3
84	22.4	64.1	23.5	65.7	24.7	67.3	25.8	68.8	26.9	70.3	28.1	71.8	29.1	73.1	30.2	74.5	31.5	76.0
88	23.3	65.4	24.5	67.0	25.7	68.7	26.9	70.3	28.1	71.8	29.4	73.4	30.6	74.9	31.7	76.3	32.7	77.5
92	24.3	66.8	25.6	68.5	26.8	70.1	28.1	71.8	29.3	73.3	30.6	74.9	31.9	76.5	33.1	77.9	34.2	79.2
96	25.2	68.0	26.7	70.0	27.6	71.1	29.4	73.5	30.2	74.5	31.8	76.4	33.2	78.0	33.9	78.9	35.7	80.9
100	26.0	69.1	27.1	70.5	29.0	72.9	30.2	74.5	31.6	76.1	32.7	77.5	33.8	78.7	35.5	80.7	36.6	82.0
104	27.1	70.5	28.4	72.2	29.4	74.0	31.1	75.5	32.7	77.5	34.0	79.0	35.8	81.0	37.1	82.5	38.5	84.1
108	28.0	71.7	29.5	73.6	30.6	74.9	32.3	77.0	33.3	78.2	35.3	80.5	36.6	82.0	38.5	84.0	39.8	85.5
112	29.2	73.2	30.2	74.5	31.9	76.5	33.1	78.0	34.9	80.0	36.6	82.0	38.0	83.5	39.8	85.5	40.8	86.5
116	30.0	74.2	32.0	76.6	32.7	77.5	34.0	79.0	35.9	81.2	38.0	83.5	39.8	85.5	41.0	86.7	42.4	88.2
120	30.7	75.0	32.7	77.5	33.6	78.5	35.8	81.0	37.4	82.9	39.4	85.0	40.9	86.6	41.9	87.7	43.6	89.4
124	31.5	76.0	33.6	78.5	34.4	79.5	36.5	81.8	38.5	84.1	40.7	86.1	41.5	87.3	43.3	89.1	44.6	90.5
128	32.1	76.8	34.0	79.0	36.2	81.5	37.5	83.0	39.2	84.8	41.4	87.2	42.9	88.7	44.6	90.5	46.6	92.5
132	32.2	78.0	34.9	80.0	36.9	82.3	38.8	84.4	40.7	86.4	42.7	88.5	44.1	90.0	46.0	91.9	48.0	93.9
136	34.0	79.0	35.6	80.8	38.0	83.5	39.7	85.4	41.7	87.5	43.8	89.7	44.8	90.7	47.4	93.3	49.7	95.5
140	35.3	80.5	37.0	82.4	38.8	84.4	40.5	86.2	42.4	88.2	44.9	90.8	46.5	92.4	48.6	94.4	50.3	96.1
144	35.8	81.1	37.8	83.3	40.0	85.7	41.4	87.2	44.1	90.0	45.6	91.5	47.8	93.7	49.7	95.5	51.5	97.2
SIDE	60		64		68		72		76		80		84		88		92	
	Area sq ft	Diam in.	Area sq ft	Diam in.	Area sq ft	Diam in.	Area sq ft	Diam in.	Area sq ft	Diam in.	Area sq ft	Diam in.	Area sq ft	Diam in.	Area sq ft	Diam in.	Area sq ft	Diam in.
42																		
44																		
46																		
48																		
50																		
52																		
54																		
56																		
58																		
60	23.5	65.7																
64	25.0	67.7	26.7	70.0														
68	26.5	69.7	28.3	72.1	30.2	74.4												
72	28.0	71.7	29.9	74.1	31.8	76.4	33.8	78.8										
76	29.5	73.6	31.6	76.1	33.5	78.4	35.7	80.9	37.7	83.2								
80	31.0	75.4	33.3	78.1	35.2	80.4	37.4	82.8	39.6	85.3	41.7	87.5						
84	32.5	77.2	34.8	79.9	37.0	82.4	39.2	84.8	41.4	87.2	43.7	89.6	46.0	91.9				
88	34.0	79.0	36.3	81.6	38.6	84.2	41.1	86.8	43.4	89.2	45.7	91.6	48.0	93.9	50.5	96.3		
92	35.6	80.8	37.9	83.4	40.3	86.0	42.9	88.7	45.3	91.2	47.7	93.6	50.1	95.9	52.7	98.3	55.1	100.5
96	37.0	82.4	39.8	85.5	42.1	87.9	44.6	90.5	47.5	93.4	49.8	95.6	51.9	97.6	55.2	100.6	57.8	103.0
100	38.4	83.9	41.2	87.0	44.3	90.2	47.5	93.4	50.2	96.0	51.9	97.6	53.3	98.9	56.7	102.0	60.1	105.0
104	40.3	86.0	42.8	88.6	46.1	92.0	48.2	94.0	51.5	97.2	53.6	99.2	57.3	102.5	59.5	104.5	62.4	107.0
108	41.7	87.5	44.1	90.0	46.9	92.8	50.1	95.9	53.0	98.6	55.6	101.0	58.5	103.6	61.0	105.8	64.7	109.0
112	42.3	88.1	45.3	91.2	48.9	94.7	51.7	97.4	54.3	99.8	57.4	102.6	58.9	104.0	63.8	108.2	67.1	111.0
116	44.1	90.0	47.6	93.5	51.1	96.8	53.7	99.3	57.0	102.3	60.1	105.0	63.3	107.8	66.2	110.2	69.3	112.8
120	45.5	91.4	49.7	95.5	51.8	97.5	55.8	101.2	58.9	104.0	62.4	107.0	65.5	109.6	69.0	112.5	72.1	115.0
124	47.1	93.0	49.8	95.6	53.8	99.4	56.7	102.0	60.1	105.0	63.6	108.0	66.2	110.2	69.3	112.8	73.3	116.0
128	47.6	93.5	51.3	97.0	55.4	100.8	58.7	103.8	61.8	106.5	65.5	109.6	68.1	111.8	72.3	115.2	76.3	118.3
132	49.7	95.5	53.0	98.6	56.3	101.6	60.1	105.0	64.2	108.5	68.4	112.0	71.8	114.8	74.6	117.0	78.5	120.0
136	50.3	96.1	54.9	100.4	58.9	104.0	62.2	106.8	64.7	109.0	69.6	113.0	72.8	115.6	76.7	118.6	81.5	122.3
140	52.4	98.1	55.6	101.0	60.4	105.3	63.8	108.2	67.8	111.5	71.4	114.5	75.6	117.8	79.1	120.5	82.7	123.2
144	54.1	99.6	57.8	103.0	61.2	106.0	64.7	109.0	69.1	112.6	73.3	116.0	78.0	119.6	81.1	122.0	85.2	125.0

*Circular equivalent diameter (d_c). Calculated from d_c = 1.3 $\frac{(ab)^{0.25}}{(a+b)^{0.25}}$

†Large numbers in table are duct class.

TABLE 7 – RECOMMENDED MAXIMUM DUCT VELOCITIES FOR LOW VELOCITY SYSTEMS (FPM)

APPLICATION	CONTROLLING FACTOR NOISE GENERATION Main Ducts	CONTROLLING FACTOR—DUCT FRICTION			
		Main Ducts		Branch Ducts	
		Supply	Return	Supply	Return
Residences	600	1000	800	600	600
Apartments Hotel Bedrooms Hospital Bedrooms	1000	1500	1300	1200	1000
Private Offices Directors Rooms Libraries	1200	2000	1500	1600	1200
Theatres Auditoriums	800	1300	1100	1000	800
General Offices High Class Restaurants High Class Stores Banks	1500	2000	1500	1600	1200
Average Stores Cafeterias	1800	2000	1500	1600	1200
Industrial	2500	3000	1800	2200	1500

TABLE 8 – VELOCITY PRESSURES

VELOCITY PRESSURE (in. wg)	VELOCITY (Ft/Min)	VELOCITY PRESSURE (in. wg)	VELOCITY (Ft/Min)	VELOCITY PRESSURE (in. wg)	VELOCITY (Ft/Min)	VELOCITY PRESSURE (in. wg.)	VELOCITY (Ft/Min)
.01	400	.29	2150	.58	3050	1.28	4530
.02	565	.30	2190	.60	3100	1.32	4600
.03	695	.31	2230	.62	3150	1.36	4670
.04	800	.32	2260	.64	3200	1.40	4730
.05	895	.33	2300	.66	3250	1.44	4800
.06	980	.34	2330	.68	3300	1.48	4870
.07	1060	.35	2370	.70	3350	1.52	4930
.08	1130	.36	2400	.72	3390	1.56	5000
.09	1200	.37	2440	.74	3440	1.60	5060
.10	1270	.38	2470	.76	3490	1.64	5120
.11	1330	.39	2500	.78	3530	1.68	5190
.12	1390	.40	2530	.80	3580	1.72	5250
.13	1440	.41	2560	.82	3620	1.76	5310
.14	1500	.42	2590	.84	3670	1.80	5370
.15	1550	.43	2620	.86	3710	1.84	5430
.16	1600	.44	2650	.88	3750	1.88	5490
.17	1650	.45	2680	.90	3790	1.92	5550
.18	1700	.46	2710	.92	3840	1.96	5600
.19	1740	.47	2740	.94	3880	2.00	5660
.20	1790	.48	2770	.96	3920	2.04	5710
.21	1830	.49	2800	.98	3960	2.08	5770
.22	1880	.50	2830	1.00	4000	2.12	5830
.23	1920	.51	2860	1.04	4080	2.16	5880
.24	1960	.52	2880	1.08	4160	2.20	5940
.25	2000	.53	2910	1.12	4230	2.24	5990
.26	2040	.54	2940	1.16	4310	2.28	6040
.27	2080	.55	2970	1.20	4380		
.28	2120	.56	2990	1.24	4460		

NOTES: 1. Data for standard air (29.92 in Hg and 70 F)

2. Data derived from the following equation:

$$h_v = \left(\frac{V}{4005} \right)^2$$

Where: V = velocity in fpm.

h_v = pressure difference termed "velocity head" (in. wg).

CHART 8 – PRESSURE DROP THRU FLEXIBLE CONDUIT

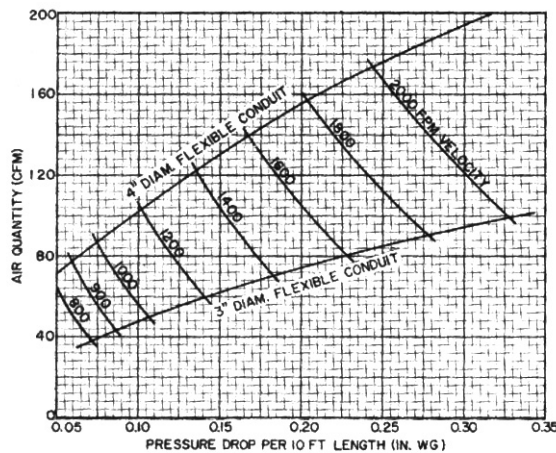

FAN CONVERSION LOSS OR GAIN

In addition to the calculations shown for determining the required static pressure at the fan discharge in *Example 4*, a fan conversion loss or gain must be included. This conversion quantity can be a significant amount, particularly on a high velocity system. It is determined by the following equations.

If the velocity in the duct is higher than the fan outlet velocity, use the following formula for the additional static pressure required:

$$\text{Loss} = 1.1 \left[\left(\frac{V_d}{4000} \right)^2 - \left(\frac{V_f}{4000} \right)^2 \right]$$

where V_d = duct velocity
 V_f = fan outlet velocity
 Loss = in. wg

If the fan discharge velocity is higher than the duct velocity, use the following formula for the credit taken to the static pressure required:

$$\text{Gain} = .75 \left[\left(\frac{V_f}{4000} \right)^2 - \left(\frac{V_d}{4000} \right)^2 \right]$$

DUCT SYSTEM ELEMENT FRICTION LOSS

Friction loss thru any fitting is expressed in terms of equivalent length of duct. This method provides units that can be used with the friction chart to determine the loss in a section of duct containing elbows and fittings. *Table 12* gives the friction losses for rectangular elbows, and *Table 11* gives the losses for standard round elbows. The friction losses in *Table 11 and 12* are given in terms of additional equivalent length of straight duct. This loss for the elbow is added to the straight run of duct to obtain the total equivalent length of duct. The straight run of duct is measured to the intersection of the center line of the

fitting. *Fig. 46* gives the guides for measuring duct lengths.

Rectangular elbows may be classified as either hard or easy bends. Hard bends are those in which the depth (depth measured in the radial direction) of the elbow is greater than the width. Hard bends result in significantly higher friction losses than do easy bends and therefore should be avoided. See note for *Table 12*, p. 2-44.

Table 9 and 10 list the friction losses for other size elbows or other R/D ratios. *Table 10* presents the friction losses of rectangular elbows and elbow combinations in terms of L/D. *Table 10* also includes the losses and regains for various duct shapes, stream of the duct. This loss or regain is expressed in the number of velocity heads and is represented by “n”. This loss or regain may be converted into equivalent length of duct by the equation at the end of the table and added or subtracted from the actual duct length.

Table 9 gives the loss of round elbows in terms of L/D, the additional equivalent length to the diameter of the elbow. The loss for round tees and crosses are in terms of the number of velocity heads (“n”). The equation for converting the loss in velocity head to additional equivalent length of duct is located at the bottom of the table.

In high velocity systems it is often desirable to have the pressure drop in round elbows, tees, and crosses in inches of water. These losses may be obtained from *Chart 9* for standard round fittings.

DESIGN METHODS

The general procedure for designing any duct system is to keep the layout as simple as possible and make the duct runs symmetrical. Supply terminals and located to provide proper room air distribution (*Chapter 3*), and ducts are laid out to connect these outlets. The ductwork should be located to avoid structural members and equipment.

The design of a low velocity supply air system may be accomplished by any one of the three following methods:

1. Velocity reduction
2. Equal friction
3. Static regain

The three methods result in different levels of accuracy, economy and use.

The equal friction method is recommended for return and exhaust air systems.

LOW VELOCITY DUCT SYSTEMS

Velocity Reduction Method

The procedure for designing the duct system by this method is to select a starting velocity at the fan discharge

TABLE 9—FRICTION OF ROUND DUCT SYSTEM ELEMENTS

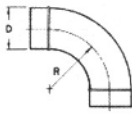
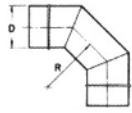
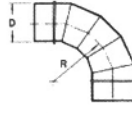
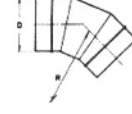
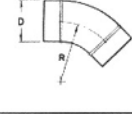
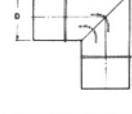
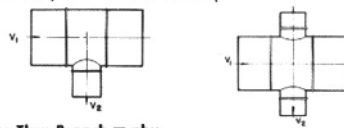
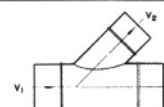
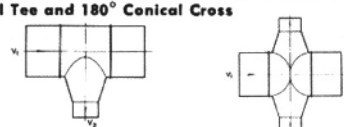
ELEMENT	CONDITION	L/D RATIO*
90° Smooth Elbow 	$R/D = 1.5$	9
90° 3-Piece Elbow 	$R/D = 1.5$	24
90° 5-Piece Elbow 	$R/D = 1.5$	12
45° 3-Piece Elbow 	$R/D = 1.5$	6
45° Smooth Elbow 	$R/D = 1.5$	4.5
90° Miter Elbow 	Vaned Not Vaned	22 65
ELEMENT	CONDITION	VALUE OF n^\dagger
90° Tee[‡] and 90°, 135° & 180° Cross[‡]  Pressure Loss Thru Branch = nhv_2	$\frac{v_2}{v_1} = \begin{cases} 0.2 \\ 0.5 \\ 1.0 \\ 5.0 \end{cases}$	4.0 2.0 1.75 1.6
45° Tee[‡]  Pressure Loss Thru Branch = nhv_2	$\frac{v_2}{v_1} = \begin{cases} 0.8 \\ 1.0 \\ 2.0 \\ 3.0 \end{cases}$.10 .44 1.21 1.47
90° Conical Tee and 180° Conical Cross  Pressure Loss Thru Branch = nhv_2	$\frac{v_2}{v_1} = \begin{cases} 0.5 \\ 1.0 \\ 2.0 \\ 5.0 \end{cases}$	0.2 0.5 1.0 1.2

Notes on page 42.

TABLE 10 – FRICTION OF RECTANGULAR DUCT SYSTEM ELEMENTS





ELEMENT	CONDITIONS	L/D RATIO †																																									
Rectangular Radius Elbow 	<table border="1"> <thead> <tr> <th rowspan="2">W/D</th> <th colspan="5">R/D</th> </tr> <tr> <th>.5</th> <th>.75</th> <th>1.00</th> <th>1.25*</th> <th>1.50</th> </tr> </thead> <tbody> <tr> <td colspan="6" style="text-align:center">L/D Ratio</td> </tr> <tr> <td>.5</td> <td>33</td> <td>14</td> <td>9</td> <td>5</td> <td>4</td> </tr> <tr> <td>1</td> <td>45</td> <td>18</td> <td>11</td> <td>7</td> <td>4</td> </tr> <tr> <td>3</td> <td>80</td> <td>30</td> <td>14</td> <td>8</td> <td>5</td> </tr> <tr> <td>6</td> <td>125</td> <td>40</td> <td>18</td> <td>12</td> <td>7</td> </tr> </tbody> </table>	W/D	R/D					.5	.75	1.00	1.25*	1.50	L/D Ratio						.5	33	14	9	5	4	1	45	18	11	7	4	3	80	30	14	8	5	6	125	40	18	12	7	
			W/D	R/D																																							
		.5		.75	1.00	1.25*	1.50																																				
L/D Ratio																																											
.5	33	14	9	5	4																																						
1	45	18	11	7	4																																						
3	80	30	14	8	5																																						
6	125	40	18	12	7																																						
Rectangular Vaned Radius Elbow 	<table border="1"> <thead> <tr> <th rowspan="2">Number of Vanes</th> <th colspan="4">R/D</th> </tr> <tr> <th>.50</th> <th>.75</th> <th>1.00</th> <th>1.50</th> </tr> </thead> <tbody> <tr> <td colspan="5" style="text-align:center">L/D Ratio</td> </tr> <tr> <td>1</td> <td>18</td> <td>10</td> <td>8</td> <td>7</td> </tr> <tr> <td>2</td> <td>12</td> <td>8</td> <td>7</td> <td>7</td> </tr> <tr> <td>3</td> <td>10</td> <td>7</td> <td>7</td> <td>6</td> </tr> </tbody> </table>	Number of Vanes	R/D				.50	.75	1.00	1.50	L/D Ratio					1	18	10	8	7	2	12	8	7	7	3	10	7	7	6													
			Number of Vanes	R/D																																							
		.50		.75	1.00	1.50																																					
L/D Ratio																																											
1	18	10	8	7																																							
2	12	8	7	7																																							
3	10	7	7	6																																							
X° Elbow 	Vaned or Unvaned Radius Elbow	X/90 times value for similar 90° elbow																																									
Rectangular Square Elbow 	No Vanes	60																																									
	Single Thickness Turning Vanes	15																																									
	Double Thickness Turning Vanes	10																																									
Double Elbow 	S = 0	15																																									
W/D = 1, R/D = 1.25*	S = D	10																																									
Double Elbow 	S = 0	20																																									
W/D = 1, R/D = 1.25*	S = D	22																																									
Double Elbow 	S = 0	15																																									
W/D = 1, R/D = 1.25* For Both	S = D	16																																									
Double Elbow 	Direction of Arrow	45																																									
W/D = 2, R₁/D = 1.25*, R₂/D = .5	Reverse Direction	40																																									
Double Elbow 	Direction of Arrow	17																																									
W/D = 4, R/D = 1.25* for both elbows	Reverse Direction	18																																									

TABLE 10 – FRICTION OF RECTANGULAR DUCT SYSTEM ELEMENTS (Contd)

ELEMENT	CONDITIONS	VALUE OF $n\frac{1}{2}$																																		
Transformer 	$V_2 = V_1$ S.P. Loss = nhv_1	.15																																		
Expansion 	<table border="1"> <thead> <tr> <th rowspan="2">v_2/v_1</th> <th colspan="6">"n" Angle "a"</th> </tr> <tr> <th>5°</th> <th>10°</th> <th>15°</th> <th>20°</th> <th>30°</th> <th>40°</th> </tr> </thead> <tbody> <tr> <td>.20</td> <td>.83</td> <td>.74</td> <td>.68</td> <td>.62</td> <td>.52</td> <td>.45</td> </tr> <tr> <td>.40</td> <td>.89</td> <td>.83</td> <td>.78</td> <td>.74</td> <td>.68</td> <td>.64</td> </tr> <tr> <td>.60</td> <td>.93</td> <td>.87</td> <td>.84</td> <td>.82</td> <td>.79</td> <td>.77</td> </tr> </tbody> </table> S.P. Regain = $n(hv_1 - hv_2)$	v_2/v_1	"n" Angle "a"						5°	10°	15°	20°	30°	40°	.20	.83	.74	.68	.62	.52	.45	.40	.89	.83	.78	.74	.68	.64	.60	.93	.87	.84	.82	.79	.77	
v_2/v_1	"n" Angle "a"																																			
	5°	10°	15°	20°	30°	40°																														
.20	.83	.74	.68	.62	.52	.45																														
.40	.89	.83	.78	.74	.68	.64																														
.60	.93	.87	.84	.82	.79	.77																														
Contraction 	<table border="1"> <thead> <tr> <th>a</th> <th>30°</th> <th>45°</th> <th>60°</th> </tr> </thead> <tbody> <tr> <td>n</td> <td>1.02††</td> <td>1.04</td> <td>1.07</td> </tr> </tbody> </table> S.P. Loss = $n(hv_2 - hv_1)$ ††Slope 1" in 4"	a	30°	45°	60°	n	1.02††	1.04	1.07																											
a	30°	45°	60°																																	
n	1.02††	1.04	1.07																																	
Abrupt Entrance 	S.P. Loss = nhv_1	.35																																		
Bellmouth Entrance 		.03																																		
Abrupt Exit 	S.P. Loss or Regain Considered Zero																																			
Bellmouth Exit 																																				
Re-entrant Entrance 	S.P. Loss = nhv_1	.85																																		
Sharp Edge Round Orifice 	<table border="1"> <thead> <tr> <th>A_2/A_1</th> <th>0</th> <th>.25</th> <th>.50</th> <th>.75</th> <th>1.00</th> </tr> </thead> <tbody> <tr> <td>n</td> <td>2.5</td> <td>2.3</td> <td>1.9</td> <td>1.1</td> <td>0</td> </tr> </tbody> </table> S.P. Loss = nhv_2	A_2/A_1	0	.25	.50	.75	1.00	n	2.5	2.3	1.9	1.1	0																							
A_2/A_1	0	.25	.50	.75	1.00																															
n	2.5	2.3	1.9	1.1	0																															
Abrupt Contraction 	<table border="1"> <thead> <tr> <th>V_1/V_2</th> <th>0</th> <th>.25</th> <th>.50</th> <th>.75</th> </tr> </thead> <tbody> <tr> <td>n</td> <td>1.34</td> <td>1.24</td> <td>.96</td> <td>.52</td> </tr> </tbody> </table> S.P. Loss = nhv_2	V_1/V_2	0	.25	.50	.75	n	1.34	1.24	.96	.52																									
V_1/V_2	0	.25	.50	.75																																
n	1.34	1.24	.96	.52																																
Abrupt Expansion 	<table border="1"> <thead> <tr> <th>V_2/V_1</th> <th>.20</th> <th>.40</th> <th>.60</th> <th>.80</th> </tr> </thead> <tbody> <tr> <td>n</td> <td>.32</td> <td>.48</td> <td>.48</td> <td>.32</td> </tr> </tbody> </table> S.P. Regain = nhv_1	V_2/V_1	.20	.40	.60	.80	n	.32	.48	.48	.32																									
V_2/V_1	.20	.40	.60	.80																																
n	.32	.48	.48	.32																																
Pipe Running Thru Duct 	<table border="1"> <thead> <tr> <th>E/D</th> <th>.10</th> <th>.25</th> <th>.50</th> </tr> </thead> <tbody> <tr> <td>n</td> <td>.20</td> <td>.55</td> <td>2.00</td> </tr> </tbody> </table> S.P. Loss = nhv_1	E/D	.10	.25	.50	n	.20	.55	2.00																											
E/D	.10	.25	.50																																	
n	.20	.55	2.00																																	
Bar Running Thru Duct 	<table border="1"> <thead> <tr> <th>E/D</th> <th>.10</th> <th>.25</th> <th>.50</th> </tr> </thead> <tbody> <tr> <td>n</td> <td>.7</td> <td>1.4</td> <td>4.00</td> </tr> </tbody> </table> S.P. Loss = nhv_1	E/D	.10	.25	.50	n	.7	1.4	4.00																											
E/D	.10	.25	.50																																	
n	.7	1.4	4.00																																	
Easement Over Obstruction 	<table border="1"> <thead> <tr> <th>E/D</th> <th>.10</th> <th>.25</th> <th>.50</th> </tr> </thead> <tbody> <tr> <td>n</td> <td>.07</td> <td>.23</td> <td>.90</td> </tr> </tbody> </table> S.P. Loss = nhv_1	E/D	.10	.25	.50	n	.07	.23	.90																											
E/D	.10	.25	.50																																	
n	.07	.23	.90																																	

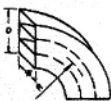
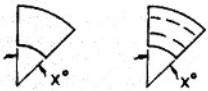
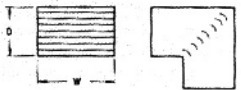
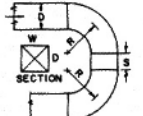
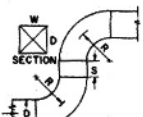
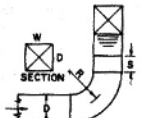
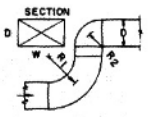
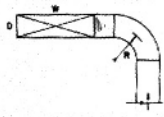
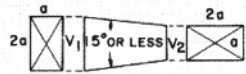
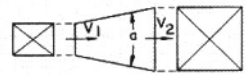
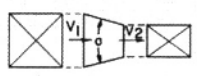
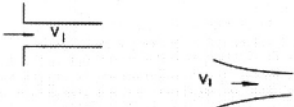
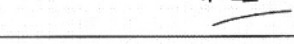
NOTES FOR TABLE 9

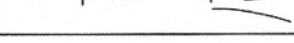
*L and D are in feet. D is the elbow diameter. L is the additional equivalent length of duct added to the measured length. The equivalent length L equals D in feet times the ratio listed.

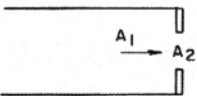
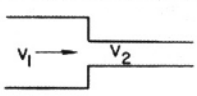
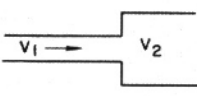
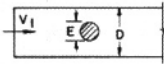
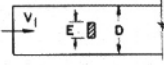
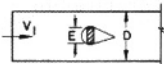
† The value of n is the loss in velocity heads and may be converted to additional equivalent length of duct by the following equation.

$$L = n \times \frac{h_v \times 100}{h_f}$$

- Where : L = additional equivalent length, ft
- h_v = velocity pressure at V_2 , in. wg (conversion line on Chart 7 or Table 8).
- h_f = friction loss/100 ft, duct diameter at V_2 , in. wg (Chart 7).
- n = value for tee or cross

‡ Tee or cross may be either reduced or the same size in the straight thru portion

NOTES FOR TABLE 10

*1.25 is standard for an unvaned full radius elbow.

† L and D are in feet. D is the duct diameter illustrated in the drawing. L is the additional equivalent length of duct added to the measured duct. The equivalent length L equals D in feet times the ratio listed.

‡ The value n is the number of velocity heads or differences in velocity heads lost or gained at a fitting, and may be converted to additional equivalent length of duct by the following equation.

$$L = n \times \frac{h_v \times 100}{h_f}$$

- Where : L = additional equivalent length, ft
- h_v = velocity pressure for V_1 , V_2 or the differences in velocity pressure, in wg (conversion line on Chart 7 or Table 8).
- h_f = friction loss/100 ft, duct cross selection at h_v , in. wg (Chart 7).
- n = value for particular fitting.

TABLE 11 – FRICTION OF ROUND ELBOWS

ELBOW DIAMETER (in.)	90° SMOOTH	90° 5-PIECE	90° 3-PIECE	45° 3-PIECE	45° SMOOTH
	$R/D = 1.5$	$R/D = 1.5$	$R/D = 1.5$	$R/D = 1.5$	$R/D = 1.5$
ADDITIONAL EQUIVALENT LENGTH OF STRAIGHT DUCT (FT)					
3	2.3	3	6	1.5	1.1
4	3	4	8	2	1.5
5	3.8	5	10	2.5	1.9
6	4.5	6	12	3	2.3
7	5.3	7	14	3.5	2.6
8	6	8	16	4	3
9	—	9	18	4.5	—
10	—	10	20	5	—
11	—	11	22	5.5	—
12	—	12	24	6	—
14	—	14	28	7	—
16	—	16	32	8	—
18	—	18	36	9	—
20	—	20	40	10	—
22	—	22	44	11	—
24	—	24	48	12	—

TABLE 12 – FRICTION OF RECTANGULAR ELBOWS





DUCT DIMENSIONS (in.)		RADIUS ELBOW NO VANES 	RADIUS ELBOW—WITH VANES‡				SQUARE ELBOWS‡	
								
W	D	Radius Ratio† R/D = 1.25	R _f = 6" (Recommended)		R _f = 3" (Acceptable)		Double Thickness Turning Vanes	Single Thickness Turning Vanes
ADDITIONAL EQUIVALENT LENGTH OF STRAIGHT DUCT (FT)								
			Vanes		Vanes			
96	48	31	45	2	43	3	40	60
	36	25	36	2	31	3	30	45
	30	22	31	2	38	2	25	37
	24	19	33	1	29	2	20	30
	20	16	28	1	25	2	17	25
72	48	28	44	2	41	3	35	60
	36	23	33	2	29	3	29	45
	30	21	28	2	33	2	25	37
	24	17	29	1	25	2	21	30
	20	15	23	1	19	2	18	25
	16	13	18	1	16	2	15	20
	12	12			15	1	11	15
60	48	27	41	2	39	3	33	60
	36	22	31	2	27	3	27	45
	30	19	25	2	31	2	23	37
	24	16	27	1	26	2	20	30
	20	14	22	1	21	2	17	25
	16	12	16	1	15	2	13	20
	12	10			14	1	10	15
48	96*	45	35	3				
	48	26	35	2	34	3	29	60
	36	20	26	2	22	3	23	45
	30	18	23	2	28	2	21	37
	24	15	24	1	21	2	18	30
	20	14	19	1	17	2	15	25
	16	11	15	1	14	2	12	20
	12	9			13	1	10	15
	10	8			11	1	8	12
	8	8			9	1	7	10
42	42	23	28	2	26	3	24	53
	36	20	24	2	21	3	22	45
	30	17	21	2	26	2	20	37
	24	15	21	1	19	2	16	30
	20	13	18	1	16	2	14	25
	16	11	14	1	13	2	12	20
	12	9			13	1	9	15
	10	8			10	1	8	12
	8	7			8	1	6	10
36	72*	34	27	3				
	36	19	22	2	19	3	20	45
	30	16	19	2	22	2	18	37
	24	14	20	1	22	2	15	30
	20	12	17	1	15	2	13	25
	16	10	13	1	12	2	11	20
	12	9			12	1	9	15
	10	8			9	1	8	12
	8	7			8	1	6	10
32	32	17	19	2	16	3	17	40
	30	16	18	2	21	2	17	37
	24	14	19	1	17	2	15	30
	20	12	16	1	14	2	12	25
	16	10	12	1	12	2	11	20
	12	8			12	1	8	15
	10	7			9	1	7	12
	8	6			8	1	6	10

TABLE 12 – FRICTION OF RECTANGULAR ELBOWS (CONT.)

DUCT DIMENSIONS (in.)		RADIUS ELBOW NO VANES	RADIUS ELBOW—WITH VANES‡		SQUARE ELBOWS‡			
W	D							
		Radius Ratio† R/D = 1.25	R _t = 6" (Recommended)	R _t = 3" (Acceptable)	Double Thickness Turning Vanes	Single Thickness Turning Vanes		
ADDITIONAL EQUIVALENT LENGTH OF STRAIGHT DUCT (FT)								
			Vaness					
28	28	15	14	2	17	2	14	34
	24	13	17	1	15	2	13	30
	20	12	15	1	13	2	12	25
	16	10	11	1	11	2	10	20
	12	8			11	1	8	15
	10	7			9	1	7	12
	8	6			8	1	6	10
24	96*	38	19	3			23	80
	72*	32	17	3			21	72
	48*	22	20	2	20	3	18	62
	24	13	16	1	14	2	12	30
	20	11	13	1	12	2	10	25
	16	10	11	1	10	2	9	20
	12	8			10	1	8	15
	10	7			8	1	7	12
	8	6			7	1	6	10
	6	5			7	1	4	8
20	80*	32	16	3			19	66
	60*	26	19	2			17	58
	40*	22	15	2	14	3	14	49
	20	11	12	1	10	2	10	25
	16	9	9	1	9	2	8	20
	12	7			9	1	7	15
	10	6			8	1	6	12
	8	5			7	1	5	10
	6	4			7	1	4	8
16	64*	26	9	3			14	48
	48*	21	12	2	12	3	12	43
	32*	15	11	2	9	3	11	38
	16	9	8	1	8	2	7	20
	12	7			8	1	6	15
	10	6			6	1	5	12
	8	5			6	1	5	10
	6	4			6	1	4	8
12	48*	19	8	2	8	3	10	33
	36*	16	7	2	7	3	9	30
	24*	11	8	1	8	2	8	26
	12	7			7	1	5	15
	10	6			5	1	5	12
	8	5			5	1	4	10
	6	4			5	1	3	8
10	40*	19	6	2	6	3	8	27
	30*	13	6	2	8	2	7	24
	20*	9	7	1	6	2	6	21
	10	5			5	1	4	12
	8	4			5	1	4	10
	6	4			5	1	3	8
8	32*	13	5	2	4	3	6	21
	24*	11	6	1	5	2	6	19
	16*	8	4	1	5	2	5	16
	8	4			4	1	3	10
	6	3			4	1	3	8
6	24*	10	4	1	4	2	4	15
	18*	8	3	1	4	2	4	13
	12*	6			4	1	3	11
	6	3					3	8

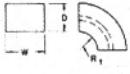
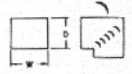
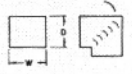
*Denotes Hard Bends as shown

Hard Bend



Easy Bend



†For other radius ratios, see Table 10.

‡For other sizes, see Table 10.

Vaness must be located as illustrated in Chart 6, page 24, to have these minimum losses.



CHART 9 – LOSSES FOR ROUND FITTINGS

Elbows, Tees and Crosses

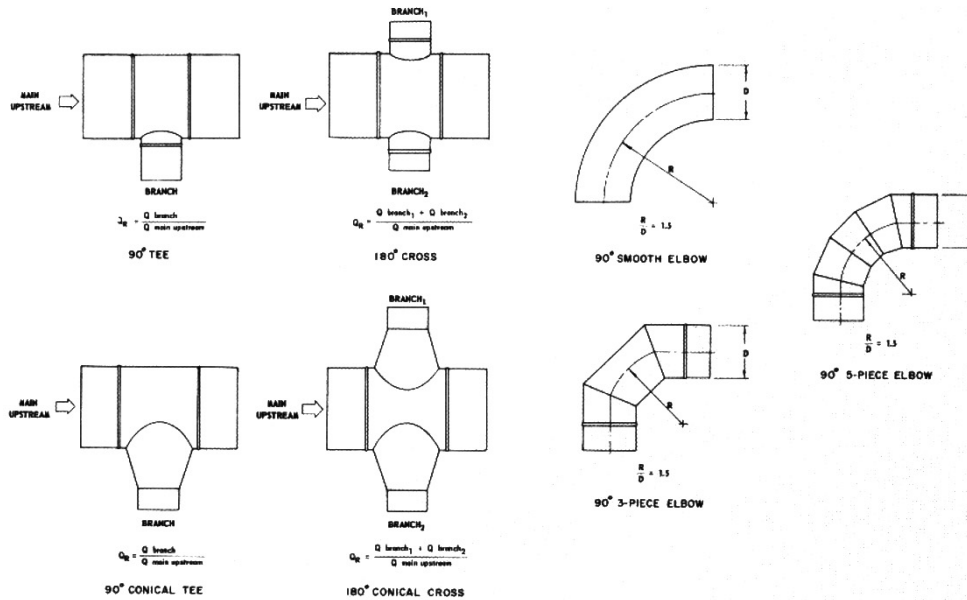
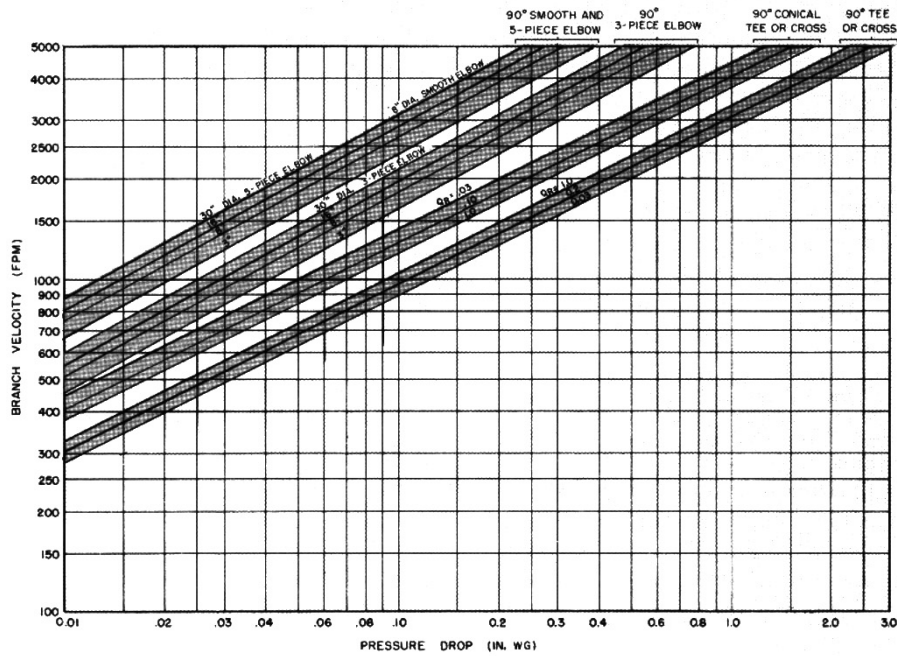

- NOTES: 1. Loss for tee or cross is a function of the velocity in the branch. This represents the loss in static pressure from the main upstream to the branch. Q_R is the ratio of air quantity of the branch to the main upstream.
 2. Loss for 45° smooth elbow is equal to one-half the loss for a 90° smooth elbow.
 3. Loss for 45° 3-piece elbow is equal to one-half the loss for a 90° 5-piece elbow.

and make arbitrary reductions in velocity down the duct run. The starting velocity selected should not exceed those in *Table 7*. Equivalent round diameters may be obtained from *Chart 7* using air velocity and air quantity. *Table 6* is used with the equivalent round diameter to select the rectangular duct sizes. The fan static pressure required for the supply is determined by calculation, using the longest run of duct including all elbows and fittings. *Table 10 and 12* are used to obtain the losses thru the rectangular elbows and fittings. The longest run is not necessarily the run with the greatest friction loss, as shorter runs may have more elbows, fitting and restrictions.

This method is not normally used, as it requires a broad background of duct design experience and knowledge to be within reasonable accuracy. It should be used only for the most simple layouts. Splitter dampers should be included for balancing purposes.

Equal Friction Method

This method of sizing is used for supply, exhaust and return air duct systems and employs the same friction loll per foot of length for the entire system. The equal friction method is superior to velocity reduction since it requires less balancing for symmetrical layouts. If a design has a

mixture of short and long runs, the shortest run requires considerable dampening. Such a system is difficult to balance since the equal friction method makes no provision for equalizing pressure drops in branches or for providing the same static pressure behind each air terminal.

The usual procedure is to select an initial velocity in the main duct near the fan. This velocity should be selected from *Table 7* with sound level being the limiting factor. *Chart 7* is used with this initial velocity and air quantity to determine the friction rate. This same friction loss is then maintained throughout the system and the equivalent round duct diameter is selected from *Chart 7*.

To expedite equal friction calculations, *Table 13* is often used instead of the friction chart; this results in the same duct sizes.

The duct areas determined from *Table 13* or the equivalent round diameters from *Chart 7* are used to select the rectangular duct sizes from *Table 6*. This procedure of sizing duct automatically reduces the air velocity in the direction of flow.

To determine the total friction loss in the duct system that the fan must overcome, it is necessary to calculate the loss in the duct run having the highest resistance. The friction loss thru all elbows and fittings in the section must be included.

TABLE 13 – PERCENT SECTION AREA IN BRANCHES FOR MAINTAINING EQUAL FRICTION

CFM CAPACITY %	DUCT AREA %	CFM CAPACITY %	DUCT AREA %	CFM CAPACITY %	DUCT AREA %	CFM CAPACITY %	DUCT AREA %
1	2.0	26	33.5	51	59.0	76	81.0
2	3.5	27	34.5	52	60.0	77	82.0
3	5.5	28	35.5	53	61.0	78	83.0
4	7.0	29	36.5	54	62.0	79	84.0
5	9.0	30	37.5	55	63.0	80	84.5
6	10.5	31	39.0	56	64.0	81	85.5
7	11.5	32	40.0	57	65.0	82	86.0
8	13.0	33	41.0	58	65.5	83	87.0
9	14.5	34	42.0	59	66.5	84	87.5
10	16.5	35	43.0	60	67.5	85	88.5
11	17.5	36	44.0	61	68.0	86	89.5
12	18.5	37	45.0	62	69.0	87	90.0
13	19.5	38	46.0	63	70.0	88	90.5
14	20.5	39	47.0	64	71.0	89	91.5
15	21.5	40	48.0	65	71.5	90	92.0
16	23.0	41	49.0	66	72.5	91	93.0
17	24.0	42	50.0	67	73.5	92	94.0
18	25.0	43	51.0	68	74.5	93	94.5
19	26.0	44	52.0	69	75.5	94	95.0
20	27.0	45	53.0	70	76.5	95	96.0
21	28.0	46	54.0	71	77.0	96	96.5
22	29.5	47	55.0	72	78.0	97	97.5
23	30.5	48	56.0	73	79.0	98	98.0
24	31.5	49	57.0	74	80.0	99	99.0
25	32.5	50	58.0	75	80.5	100	100.0

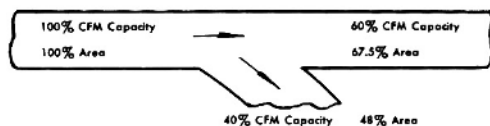

Example 4 – Equal Friction Method of Designing Ducts

Given:

- Duct systems for general office (Fig.47).
- Total air quantity – 5400 cfm
- 18 air terminals – 300 cfm each
- Operating pressure for all terminals – 0.15 in. wg
- Radius elbows, R/D = 1.25

Find:

1. Initial duct velocity, area, size and friction rate in the duct section from the fan to the first branch.
2. Size of remaining duct runs.
3. Total equivalent length of duct run with highest resistance.
4. Total static pressure required at fan discharge.

Solution:

1. From Table 7 select an initial velocity of 1700 fpm.

$$\text{Duct area} = \frac{5400 \text{ cfm}}{1700 \text{ fpm}} = 3.18 \text{ sqft}$$

From Table 6, select a duct size-22 in.x22 in.
 Initial friction rate is determined from Chart 7 using the air quantity (5400), and the equivalent round duct diameter from Table 6. Equivalent round duct diameter = 24.1 in.
 Friction rate = .145 in. wg per 100 ft of equivalent length.

2. The duct areas are calculated using Table 13 and duct sizes are determined from Table 6. The following tabulates the design information:

DUCT SECTION	AIR QUANTITY (cfm)	CFM* CAPACITY (%)
To A	5400	100
A – B	3600	67
B – 13	1800	33
13 – 14	1500	28
14 – 15	1200	22
15 – 16	900	17
16 – 17	600	11
17 – 18	300	6

DUCT SECTION	DUCT AREA (%)	AREA † (sq ft)	DUCT SIZE ‡ (in.)
To A	100.0	3.18	22 x 22
A – B	73.5	2.43	22 x 16
B – 13	41.0	1.3	22 x 10
13 – 14	35.5	1.12	18 x 10
14 – 15	29.5	.94	14 x 10
15 – 16	24.0	.76	12 x 10
16 – 17	17.5	.56	8 x 10
17 – 18	10.5	.33	8 x 10

*Percent of cfm = $\frac{\text{air quantity in duct section}}{\text{total air quantity}}$

- † Duct area = percent of area times initial duct area (fan to A)
- ‡ Refer to page 21 for reducing duct size.

Duct sections B thru 12 and A thru 6 have the same dimension as the corresponding duct sections in B thru 18.

3. It appears that the duct run from the fan to terminal 18 has the highest resistance. Tables 10 and 12 are used to determine the losses thru the fittings. The following list is a tabulation of the total equivalent length in this duct run:

DUCT SECTION	ITEM	LENGTH (ft)	ADD. EQUIV. LENGTH (ft)
To A	Duct	60	
	Elbow		12
A – B	Duct	20	
B – 13	Duct	30	
--	Elbow		7
13 – 14	Duct	20	
14 – 15	Duct	20	
15 – 16	Duct	20	
16 – 17	Duct	20	
17 – 18	Duct	20	
Total		210	19

4. The total friction loss in the ductwork from the fan to last terminal 18 is shown in the following:

$$\text{Loss} = \text{total equiv length} \times \text{friction rate}$$

$$= 229 \text{ ft} \times \frac{.145 \text{ in. wg}}{100 \text{ ft}} = .332 \text{ or } .33 \text{ in. wg}$$

Total static pressure required at fan discharge is the sum of the terminal operating pressure and the loss in the ductwork. Credit can be taken for the velocity regain between the first and last sections of duct:

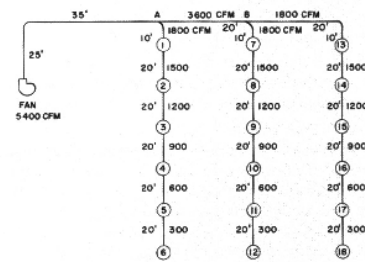

Fig. 47 – Duct Layout for Low Velocity System (Examples 4 and 5)

Velocity in initial section = 1700 fpm

Velocity in last section = 590 fpm

Using a 75% regain coefficient,

$$\begin{aligned} \text{Regain} &= .75 \left[\left(\frac{1700}{4000} \right)^2 - \left(\frac{590}{4000} \right)^2 \right] \\ &= .75(.18-.02) = .12 \text{ in. wg} \end{aligned}$$

Therefore, the total static pressure at fan discharge:

$$\begin{aligned} &= \text{duct friction} + \text{terminal pressure} - \text{regain} \\ &= .33 + .15 - .12 \\ &= .36 \text{ in. wg} \end{aligned}$$

The equal friction method does not satisfy the design criteria of uniform static pressure at all branches and air terminals. To obtain the proper air quantity at the beginning of each branch, it is necessary to include a splitter damper to regulate the flow to the branch. It may also be necessary to have a control device (vanes, volume damper, or adjustable terminal volume control) to regulate the flow at each terminal for proper air distribution.

In *Example 4*, if the fan selected has a discharge velocity of 2000 fpm, the net credit to the total static pressure required is determined as described under "*Fan Conversion Loss or Gain:*"

$$\begin{aligned} \text{Gain} &= .75 \left[\left(\frac{2000}{4000} \right)^2 - \left(\frac{1700}{4000} \right)^2 \right] \\ &= .75(.25 - .18) = .05 \text{ in. wg} \end{aligned}$$

Static Regain Method

The basic principle of the static regain method is to size a duct run so that the increase in static pressure (regain due to reduction in velocity) at each branch or air terminal just offsets the friction loss in the succeeding section of duct. The static pressure is then the same before each terminal and at each branch.

The following procedure is used to design a duct system by this method: select a starting velocity at the fan discharge from Table 7 and size the initial duct section from Table 6.

The remaining sections of duct are sized from *Chart 10 (L/Q Ratio)* and *Chart 11 (Low Velocity Static Regain)*. *Chart 10* is used to determine the *L/Q ratio* knowing the air quantity (*Q*) and length (*L*) between outlets or branches in the duct section to be sized by static regain. This length (*L*) is the equivalent length between the outlets or branches, including elbows, except transformations. The effect of the transformation section is accounted for in "*Chart 11 3 Static Regain.*" This assumes that the transformation section is laid out according to the recommendation presented in this chapter.

Chart 11 is used to determine the velocity in the duct section that is being sized. The values of the *L/Q ratio (Chart 10)* and the velocity (*V1*) in the duct section immediately before the one being sized are used in *chart 11*. The velocity (*V2*) determined from *Chart 11* is used with the air quantity to arrive at the duct area. This duct area is used in *Table 6* to size the rectangular duct and to obtain the equivalent round duct size. By using this duct size, the friction loss thru the length of duct equals the increase in static pressure due to the velocity change after each branch take-off and outlet. However, there are instances when the reduction in area is too small to warrant a change in duct size after the outlet, or possibly when the duct area is reduced more than is called for. This gives a gain or loss for the particular duct section that the fan must handle. Normally, this loss or gain is small and, in most instances, can be neglected.

Instead of designing a duct system for zero gain or loss, it is possible to design for a constant loss or gain thru all or part of the system. Designing for a constant loss increases operating cost and balancing time and may increase the fan motor size. Although not normally recommended, sizing for a constant loss reduces the duct size.

Example 5 – Static Regain Method of Designing Ducts

Given :

Duct layout (*Example 4 and Fig. 47*)

Total air quantity – 5400 cfm

Velocity in initial duct section – 1700 fpm (*Example 4*)

Unvaned radius elbow, R/D = 1.25

18 air terminals – 300 cfm each

Operating pressure for all terminals – 0.15 in. wg

Find :

1. Duct sizes.
2. Total static pressure required at fan discharge.

Solution :

1. Using an initial velocity of 1700 fpm and knowing the air quantity (5400 cfm), the initial duct area after the fan discharge equals 3.18 sq ft. From Table 6, a duct size of 22" X 22" is selected. The equivalent round duct size from Table 6 is 24.1 in. and the friction rate from Chart 7 is 0.145 in. wg per 100 ft of equivalent length. The equivalent length of duct from the fan discharge to the first branch :

$$\begin{aligned} &= \text{duct length} + \text{additional length due to fittings} \\ &= 60 + 12 = 72 \text{ ft} \end{aligned}$$

The friction loss in the duct section up to the first branch:

$$= \text{equiv length of duct} \times \text{friction rate}$$

$$= 72 \times$$

The remaining duct sections are now sized.

CHART 10 – L/Q RATIO

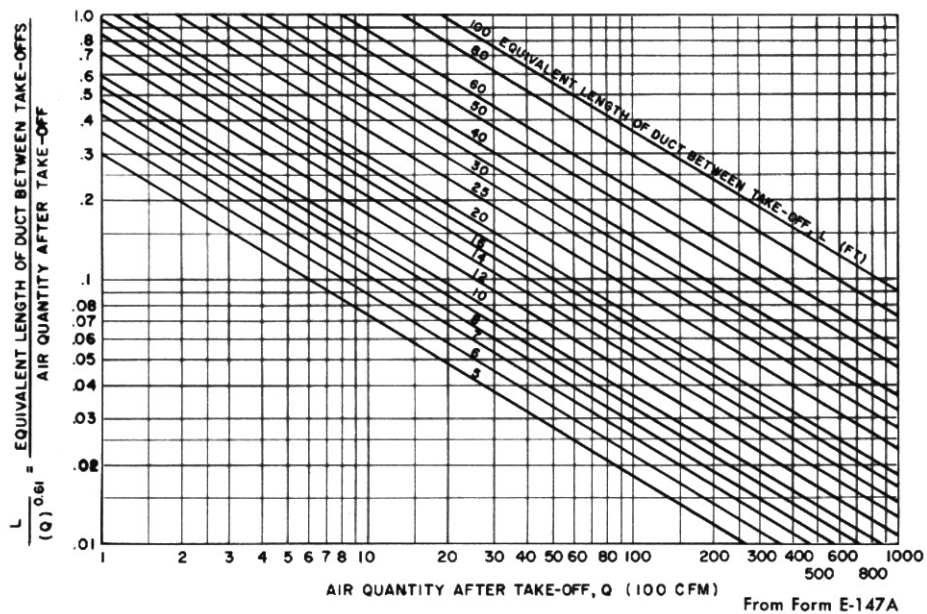
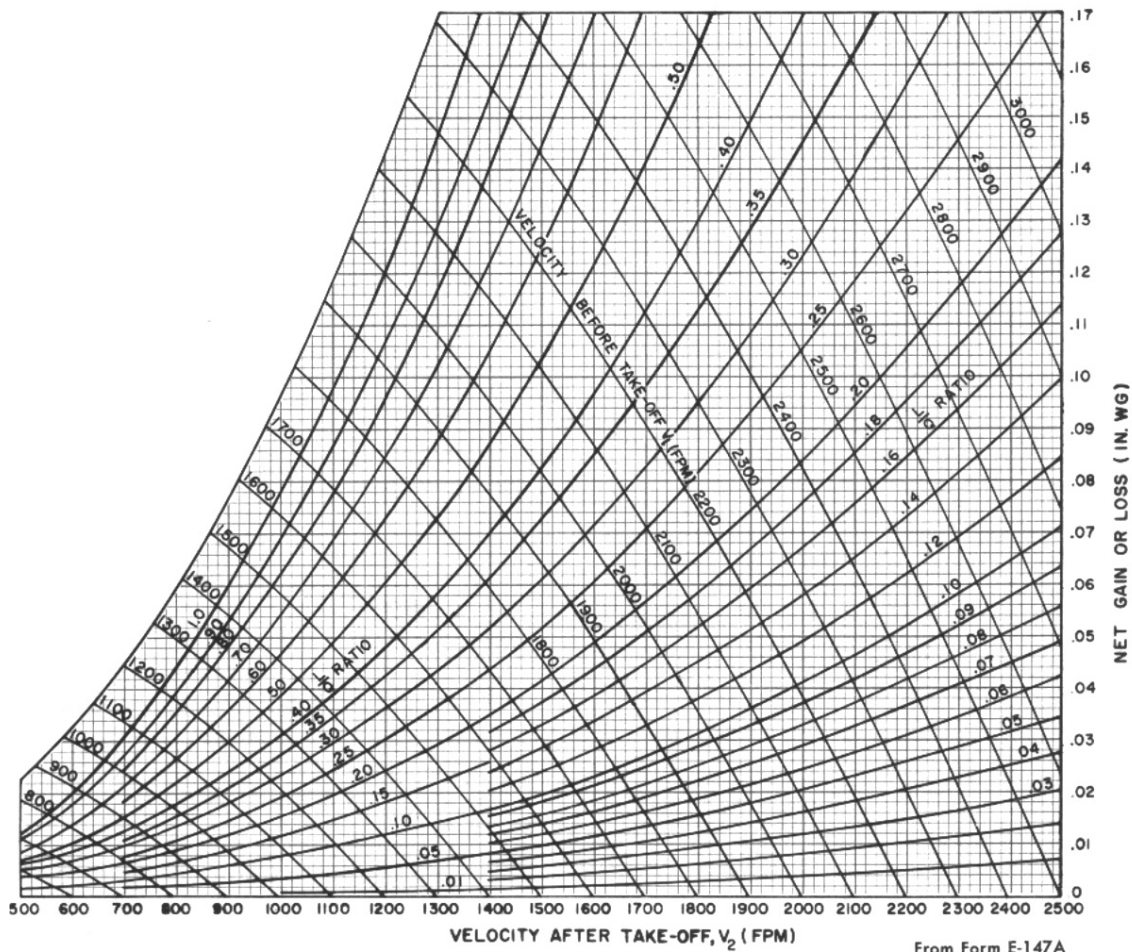

CHART 11 – LOW VELOCITY STATIC REGAIN



The longest duct run (*A to outlet 18, Fig. 47*) should be sized first. In this example, it is desirable to have the static pressure in the duct immediately before outlets 1 and 7 equal to the static pressure before outlet 13.

Figure 48 tabulates the duct sizes.

- The total pressure required at the fan discharge is equal to the sum of the friction loss in the initial duct section plus the terminal operating pressure.

Fan discharge pressure:

$$= \text{friction loss} + \text{terminal pressure}$$

$$= .104 + .15 = .25 \text{ in. wg}$$

It is good design practice to include splitter dampers to regulate the flow to the branches, even though the static pressure at each terminal is nearly equal.

Comparison of Static Regain and Equal Friction Methods

Example 4 and 5 show that the header duct size determined by the equal friction or static regain method are the same. However, the branch ducts, sized by static regain, are larger than the branch ducts sized by equal friction.

Figure 49 shows a comparison of duct sizes and weight established by the two methods.

The weight of sheet metal required for the system designed by static regain is approximately 13% more than the system designed by equal friction. However, this increase in first cost is offset by reduced balancing time and operating cost.

If it is assumed that a low velocity air handling system is used in *Examples 3 and 4* and that a design air flow of 5400 cfm requires a static pressure of 1.5 in. wg, The increased horsepower required for other equal friction design is determined in the following manner.

	STATIC REGAIN METHOD S.P. (in. wg)	EQUAL FRICTION METHOD S.P. (in. wg)
Air handling equipment	1.5	1.5
Duct friction	.104	.33
Terminal pressure	.15	.15
Static regain credit	-	-.12
Total	1.75	1.86

$$\text{Additional hp} = \frac{1.86 - 1.75}{1.75} = 6.3\% \text{ approx.}$$

A 6% increase in horsepower often indicates a larger fan motor and subsequent increased electrical transmission costs.

HIGH VELOCITY DUCT SYSTEMS

A high velocity air distribution system uses higher air velocities and static pressures than a conventional system. The design of a high velocity system involves a compromise between reduced duct sizes and higher fan horsepower. The reduced duct size is a savings in building space normally allotted to the air conditioning ducts.

Usually Class II fans are required for the increased static pressure in a high velocity system and extra care must be taken in duct layout and construction. Ducts are normally sealed to prevent leakage of air which may cause objectionable noise. Round ducts are preferred to rectangular because of greater rigidity. *Spira-Pipe* should be used whenever possible, since it is made of lighter gage metal than corresponding round and rectangular ducts, and does not require bracing.

Symmetry is a very important consideration when designing a duct system. Maintaining as symmetrical a system as possible reduces balancing time, design time and layout. Using the maximum amount of symmetrical duct runs also reduces construction and installation costs.

Particular care must be given to the selection and location of fittings to avoid excessive pressure drops and possible noise problem. *Figure 50* illustrates the minimum distance of six duct diameters between elbows and 90° tees. If a 90° conical tee is used, the next fitting in the direction of air flow may be located a minimum of one-half duct diameter away (*Fig. 51*). The use of a conical tee is limited to header ductwork and then only for increased initial velocities in the riser.

When laying out the header ductwork for a high velocity system, there are certain factors that must be considered:

- The design friction losses from the fan discharge to a point immediately upstream of the first riser take-off from each branch header should be as nearly equal as possible. These points of the same friction loss are shown in *Fig. 52*.
- To satisfy the above principle when applied to multiple headers leaving the fan, and to take maximum advantage of allowable high velocity, adhere to the following basic rule wherever possible: Make as nearly equal as possible the ratio of the total equivalent length of each header

Total S.P. Loss for supply duct system = S.P. for critical duct ___ in. wg plus air outlet S.P. loss ___ in. wg = ___ in. wg.

1	2	3	4	5		6		7	8	9
SECTION NO.	AIR QUANTITY Q (cfm)	EQUIV. LENGTH L (ft)	L/Q RATIO	VELOCITY V (fpm)		AREA (sq ft)		DUCT DIAM. OR RECT. SIZE† (in.)	FRICTION LOSS OR TAKE-OFF TO TAKE-OFF S.P. CHANGE (in. wg)	TOTAL S.P. LOSS IN DUCT (in. wg)
				Indicated	Selected	Indicated	Selected			
Fan to A	5400	72		1700		3.18		22 x 22	0.104	0.104
A - B	3600	20	.135	1510		2.38		22 x 16		
B - 13	1800	37*	.39	1170		1.54		22 x 10		
13 - 14	1500	20	.23	1000		1.50		22 x 10		
14 - 15	1200	20	.26	850		1.41		22 x 10		
15 - 16	900	20	.32	720		1.25		20 x 10		
16 - 17	600	20	.41	590		1.01		16 x 10		
17 - 18	300	20	.63	480		.63		10 x 10		
B - 7	1800	17*						22 x 10		
7 - 8	1500	20						22 x 10		
8 - 9	1200	20						22 x 10		
9 - 10	900	20						20 x 10		
10 - 11	600	20						16 x 10		
11 - 12	300	20						10 x 10		
A - 1	1800	17*						22 x 10		
1 - 2	1500	20						22 x 10		
2 - 3	1200	20						22 x 10		
3 - 4	900	20						20 x 10		
4 - 5	600	20						16 x 10		
5 - 6	300	20						10 x 10		

From Form E-147

*Duct size is assumed to determine loss thru elbow.
 †Duct sizes from Table 6. Longest duct run is sized first. Remaining duct sections are the same size, as they are symmetrical to branch B thru 18. If other branches are

not symmetrical and handle different air quantities, an initial velocity is assumed at the beginning of the branch. This velocity is somewhat less than the velocity in the header before take-off.

Fig. 48 – Duct Sizing Calculation Form

DUCT SECTION	EQUAL FRICTION METHOD		STATIC REGAIN METHOD	
	Duct Dimensions (in.)	Duct Weight (lb)	Duct Dimensions (in.)	Duct Weight (lb)
To A	22 x 22	592	22 x 22	592
A to B	22 x 16	179	22 x 16	179
A-1, B-7, B-13	22 x 10	394	22 x 10	394
1-2, 7-8, 13-14	18 x 10	411	22 x 10	438
2-3, 8-9, 14-15	14 x 10	360	22 x 10	438
3-4, 9-10, 15-16	12 x 10	321	20 x 10	435
4-5, 10-11, 16-17	8 x 10	270	16 x 10	384
5-6, 11-12, 17-18	8 x 10	270	10 x 10	297
Total weight of duct*		2797		3157
Allow 15% for scrap		420		475
Total wt of sheet metal		3217		3632

*Total weight includes transformation and elbows.

Fig. 49 – Comparison of Duct Sizing Methods

run (fan discharge to the first riser take-off) to the initial header diameter (L/D ratio). Thus the longest *Spira-Pipe* header run should preferably have the highest air quantity so that the highest velocities can be used throughout.

- Unless space conditions dictate otherwise, the take-off from the header should be made using a 90° tee or 90° conical tee rather than a 45° tee. By using 90° fittings, the pressure drop to the branch throughout the system is more uniform. In addition, two fittings are normally required when a 45° tee is used and only one when a 90° fitting is used, resulting in lower first cost.

The design of a high velocity system is basically the same as a low velocity duct system designed for static regain. The air velocity is reduced at each take-off to the riser and air terminals. This reduction in velocity results in a recovery of static pressure (velocity regain) which offsets the friction loss in the succeeding duct section.

The initial starting velocity in the supply header depends on the number of hours of operation. To achieve an economic balance between first cost and operating cost, lower air velocities in the header are recommended for 24-hour operation where space permits. When a 90° conical tee is used instead of a 90° tee for the header to branch take-off, a higher initial starting velocity in the branch is recommended. The following table suggests initial velocities for header and branch duct sizing:

RECOMMENDED INITIAL VELOCITIES
USED WITH CHARTS 12 AND 13 (fpm)

HEADER	
12 hr. operation	3000 – 4000
24 hr. operation	2000 – 3500
BRANCH *	
90° conical tee	4000 – 5000
90° tee	3500 – 4000
Take-Offs To Terminals	2000 maximum

* Branches are defined as a branch header or riser having 4 to 5 or more take-offs to terminals

Static regain charts are presented for the design of high velocity system. *Chart 12* is used for designing branches and *Chart 13* is used for header design. The basic difference in the two charts is the air quantity for the duct sections.

Chart 12 is used for sizing risers and branch headers handling 6000 cfm or less. The chart is based on 12 ft increments between take-offs to the air terminals in the branches or take-offs to the risers in branch headers. A scale is provided to correct for spacings more or less than 12 ft.

Chart 13 is used to size headers, and has an air quantity range of 1000 to 40,000 cfm. The chart is based on 20 ft increments between branches. A correction scale at the top of the chart is used when take-off to branch is more or less than 20 ft.

Example 6 and 7 are presented to illustrate the use of these two charts. *Example 6* is a branch sizing problem for the duct layout in *Fig. 53*, and *Example 7* is a header layout (*Fig. 55*).

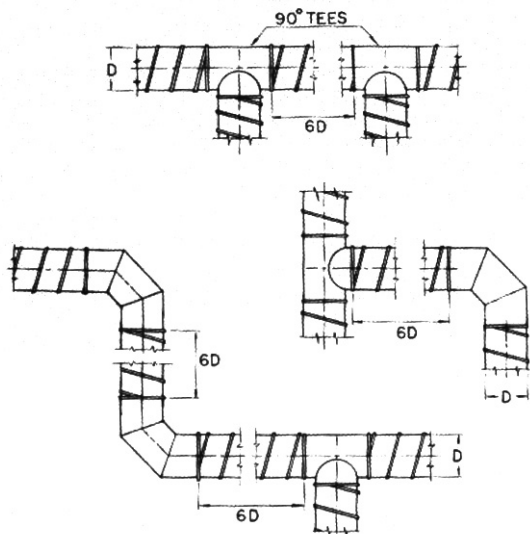

Fig. 50 – Spacing of Fitting in Duct Run

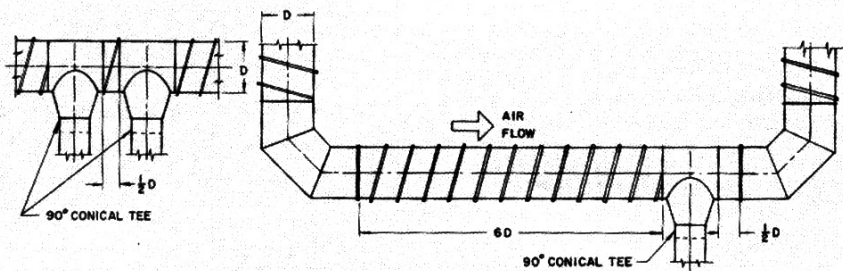
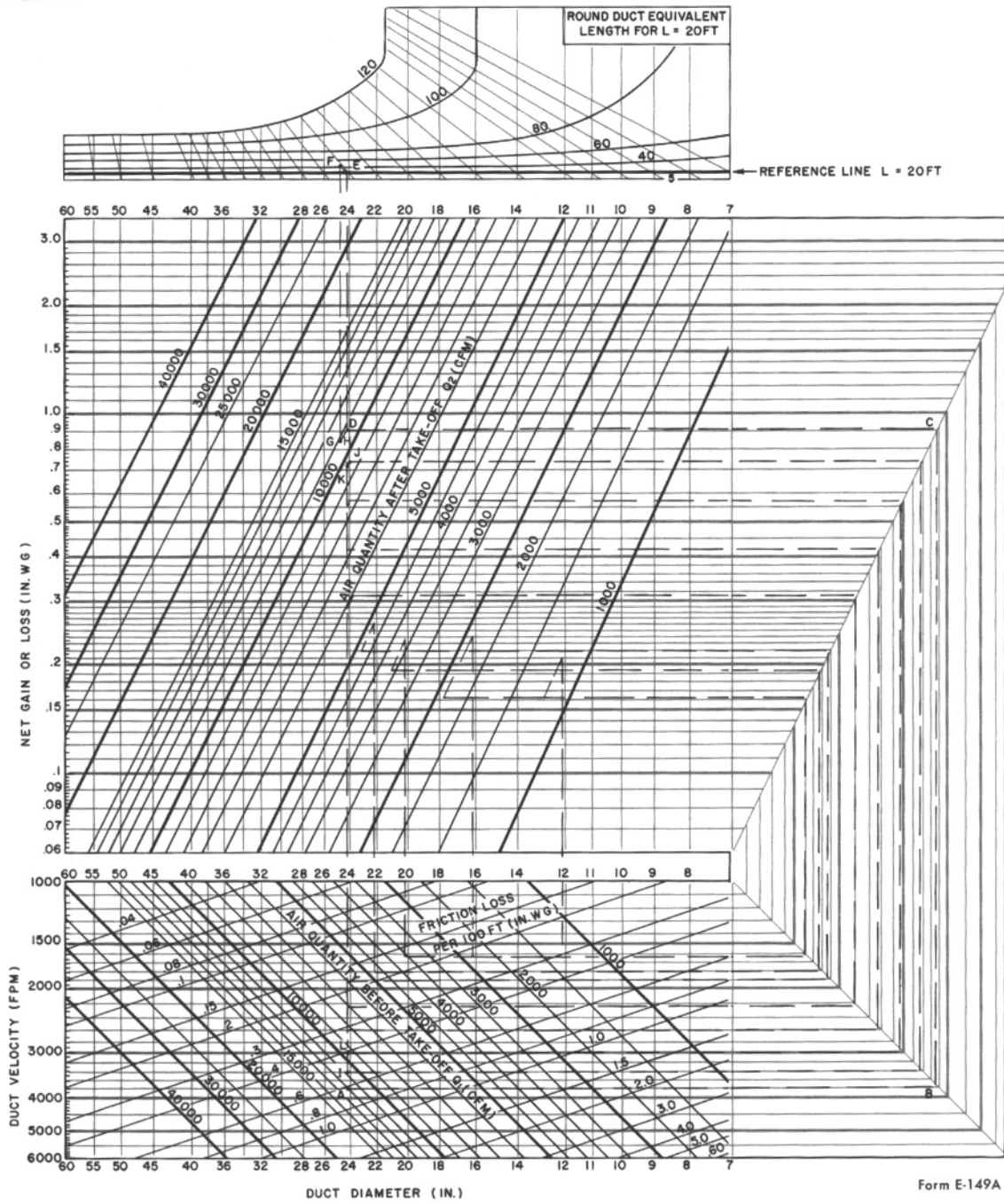

Fig. 51 – Spacing of Fitting When Using 90° Conical Tee

CHART 12 – BRANCH HIGH VELOCITY STATIC REGAIN



Form E-149A

CHART 13 – HEADER HIGH VELOCITY STATIC REGAIN

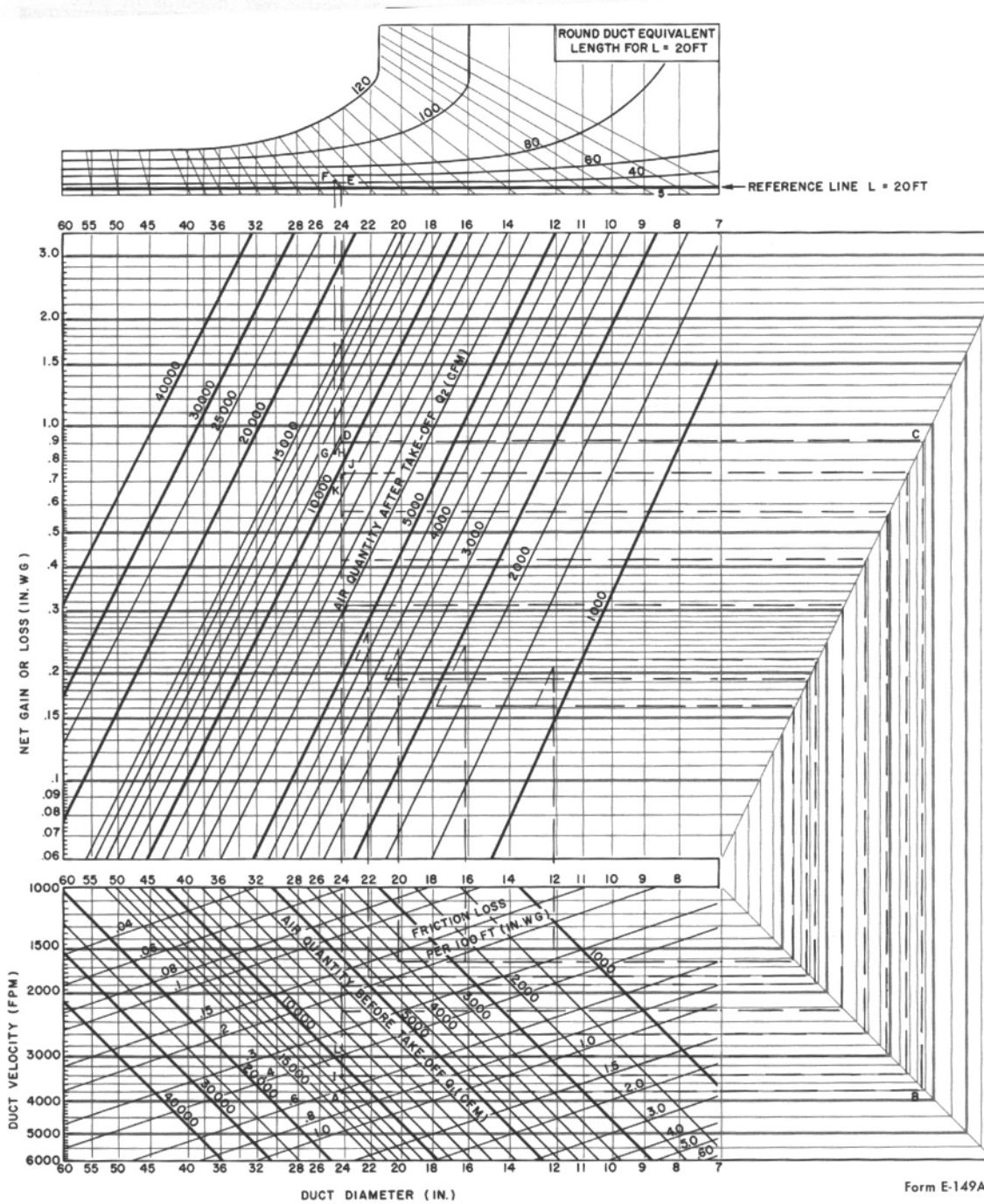

Form E-149A

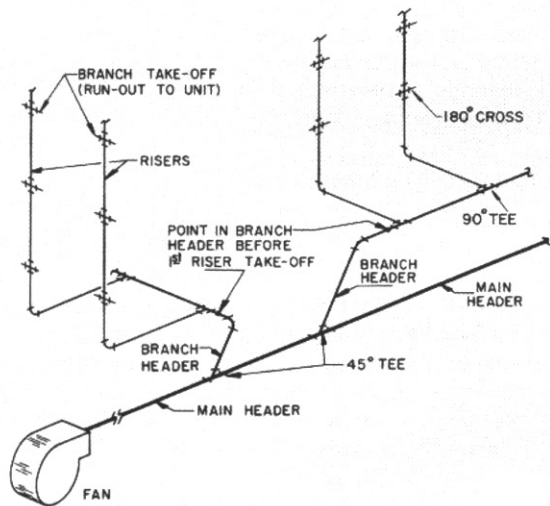

Fig. 52 – High Velocity Headers and Branches

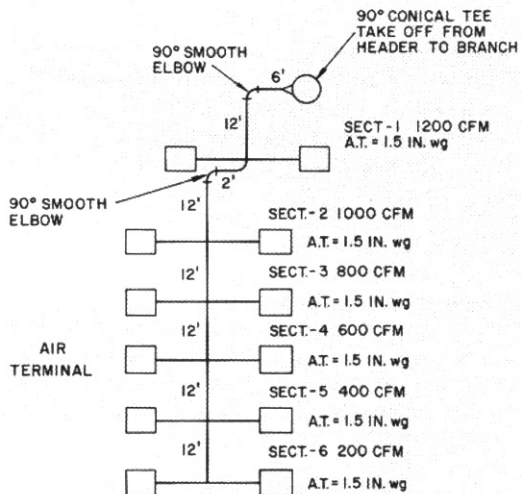

Fig. 53 – Branch Duct for Example 6

Example 6 – Use of Branch Duct Sizing Chart

Given:

- Office building riser as shown in Fig. 53
- 12 air terminals – 100 cfm each
- Total air quantity – 1200 cfm
- Air terminal static pressure – 1.5 in. wg

Find:

Duct size for Section 1 thru 6, Fig. 53.

Solution:

1. Sketch branch as shown in Fig. 53. Enter appropriate values in column 2, 3 and 8, Fig. 54.
2. Enter Chart 12 at the velocity range recommended for branch risers with a 90° conical tee, page 52.

3. Intersect the initial branch air quantity, 1200 cfm, as shown at point A. Read 7 in. duct size and 3.8 in. wg loss per 100 ft of equivalent pipe and 4500 fmp velocity. Enter these values on the high velocity calculations form (Fig. 54).
4. From point A, determine header take-off loss by projection horizontally to the left of point A and read 1.25 in. wg.
5. Enter 1.25 in. wg in Fig. 54 for section 1.
6. Determine equivalent length from the header to the first air terminal take-off:

INITIAL CONDITIONS: Cfm 1200; Duct Size 7 in.; Velocity 4500 fpm.

1	2	3	4		6	7	8	9	10	
			PRESSURE READING (in. wg)							
BRANCH SECT. NO.	AIR QUAN-TITY Q (cfm)	EQUIV. DUCT LENGTH L (ft)	Initial	Selected	TAKE-OFF TO TAKE-OFF S.P. CHANGE (4 minus 5) (in. wg)	S.P. AHEAD OF TAKE-OFF (in. wg)	AIR TERMI-NAL PRESS. (in. wg)	DUCT SIZE (in.)	VELOC-ITY V (fpm)	
			1	1200						23.3
2	1000	24.6	1.0	1.25	- 0.25	2.39	1.5	7	3700	
3	800	12	0.84	0.84	0.0	2.39	1.5	7	3050	
4	600	12	0.57	0.47	+ 0.1	2.29	1.5	7	2300	
5	400	12	0.32	0.40	- 0.085	2.37	1.5	6	2050	
6	200	12	0.26	0.24	+ 0.02	2.35	1.5	5	1475	
Maximum S. P. is at Section 2:						2.39	+ 1.5	+ .19	= 4.08	

From Form E-148

Fig. 54 – High Velocity Branch Sizing Calculations

Length of pipe = 6 + 12 = 18 ft. One 7 in. smooth ell = 5.3 ft. Total equivalent length = 18 + 5.3 = 23.3 ft. Pressure drop = $23.3 \times 3.8/100 = .89$ in. wg.

7. Determine duct size for section 2:
From point A on *Chart 12*, project thru point B and C to the 1000 cfm line at point D.
8. Determine equivalent length for section 2:
Actual duct length = 12 + 2 = 14 ft. Two smooth 90 ells = $2 \times 5.3 = 10.6$ ft. Total equivalent length = 14 + 10.6 = 24.6 ft.
9. Determine pressure loss in section 2:
Project vertically from point D to reference line, then to point E. Proceed on the guide lines to 24.6 ft equivalent length, point F. Project vertically from F to 1000 cfm line at point H. Enter point H (1.25 in. wg) and point G (1.01 in. wg) in *Fig 54*, columns 4 and 5. The net loss in "point H – point G" = $1.25 - 1.00 = .25$ in. wg. This is entered in column 6 of *Fig. 54*. Enter 7 in. diameter in column 9.
10. Determine duct size for section 3:
Project downward on the 7 in. diameter line to the 1000 cfm line, point H to I.
11. Project along guide lines at the right side of the chart from I to the 800 cfm line at point J. Duct size is 7 in. Enter appropriate values from the chart in column 4, 5, 6 and 9 of *Fig. 54*.
12. Determine duct size for section 4:
Project downward on the 7 in. diameter line to the 800 cfm line, point J to K.
13. Project along guide lines at the right side of the chart from point K to the 600 cfm line at point L. Project along the 600 cfm line to the 7 in. diameter line, point L to M. This results in a static regain of $.57 - .47 = .10$ in. wg. Duct size for section 4 is 7 in. Enter appropriate values in *Fig. 54*, columns 4, 5, 6, 7 and 9.
NOTE: If the 600 cfm line is projected from point L to the 6 in. diameter line, a net loss of $.88 - .45 = .43$ in. wg results. This friction loss unnecessarily penalizes the system. Therefore, the projection from L is made to the 7 in. diameter line.
14. Determine duct size for section 5: Project downward from M to 600 cfm line, point N. Project along guide lines to 400 cfm line, point O. Continue along the 400 cfm line to the 6 in. diameter line, point O to P. This results in a static pressure loss of $.40 - .315 = .085$ in. wg. Duct size is 6 in. Enter the appropriate values in *Fig. 54*, columns 4, 5, 6, 7 and 9.
NOTE: If the 400 cfm is projected from point O to the 7 in diameter line, a net regain of $.315 - .20 = .115$ in. wg results. Therefore, the 6 in. size is used to save on first cost since the net loss using the 6 in. size is insignificant.
15. Determine duct size for section 6:
Duct size is 5 in. as determined from point S.

16. Determine velocities for duct sections 1-6 from points A, I, K, N, Q and T respectively; enter in column 10.
17. Determine take-off and runout pressure drop by entering upper right hand portion of *Chart 12* At 100 cfm and read a pressure drop of .19 in. wg for a 4 in. runout size.
18. Add 2.39 in. wg (maximum from column 7) plus 1.5 in. wg (column 8) plus .19 (take-off and runout drop) to find 4.08 in. wg (total branch S.P.)

Example 7 – Use of Header Sizing Chart

Given:

- Office building, 12-hour operation
- Header as shown in *Fig. 55*
- 10 branches – 1200 cfm each
- Total air quantity – 12,000 cfm

Find:

Header size for section 1 thru 10

Solution:

1. Sketch header as shown in *Fig. 55*. Enter appropriate values in *Fig. 56*, columns 1, 2, 3 and 8.
2. Enter *Chart 13* at the velocity range recommended for headers in a system operating 12 hours. *Page 52*.
3. Intersect the initial header air quantity 12,000 cfm as shown, at point A. Read 24 in. duct size and .62 in. wg loss per 100 ft of equivalent pipe and 3800 fmp. Enter these values on high velocity calculation form. (*Fig. 56*).
4. Calculate the equivalent length of section 1 and record in column 3; straight duct = 20 feet, no fittings; pressure drop – $20 \times .62 = .124$ in. wg.
5. Size duct section: From point A on chart, project thru point B and C to the 10,800 cfm line at point D.
6. Determine equivalent length for section 2: Actual length = 20 ft. One 5-piece 90° ell = 24 ft. Total equivalent length = $20 + 24 = 44$ ft.
7. Determine pressure loss in section 2: Project vertically from point D to reference line, point E. Proceed on the guide lines to 44 ft. equivalent length, point F. Project vertically from F to 10,800 cfm line at point G, then along

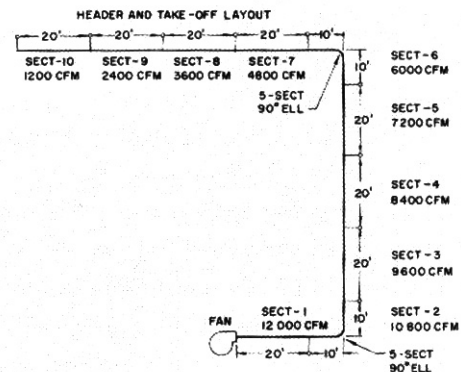

Fig. 55 – High Velocity Duct System – Header Static Regain Method Sizing

INITIAL CONDITIONS: Cfm 12,000; Duct Size 24 in.; Velocity 3800 fpm.

1	2	3	4		5	6	7	8	9	10
HEADER SECT. NO.	AIR QUAN-TITY Q (cfm)	EQUIV. DUCT LENGTH L (ft)	PRESSURE READING (in. wg)		TAKE-OFF TO TAKE-OFF S.P. CHANGE (4 minus 5) (in. wg)	S.P. AHEAD OF TAKE-OFF (in. wg)	BRANCH S.P. (in. wg)	DUCT SIZE (in.)	VELOC-ITY V (fpm)	
			Initial	Selected						
1	12000	20	Duct Friction = 0.124			0.124	4.08	24	3800	
2	10800	44	0.84	0.90	-0.06	0.184	4.08	24	3400	
3	9600	20	0.74	0.70	+0.04	0.144	4.08	24	3000	
4	8400	20	0.57	0.55	+0.02	0.124	4.08	24	2600	
5	7200	20	0.42	0.42	0.0	0.124	4.08	24	2250	
6	6000	44	0.31	0.30	+0.01	0.114	4.08	24	1900	
7	4800	20	0.22	0.26	-0.04	0.154	4.08	22	1800	
8	3600	20	0.195	0.23	-0.035	0.189	4.08	20	1650	
9	2400	20	0.165	0.24	-0.075	0.264	4.08	16	1650	
10	1200	20	0.165	0.21	-0.045	0.309	4.08	12	1500	

Maximum S.P. at Section 10 = 0.31 + 4.08 = 4.39

Fig. 56 – High Velocity Header Sizing Calculations

From Form E-149

the 10,800 cfm line to point H. Enter the net loss read from point G (.84) and from point H (.90) in columns 4 and 5, Fig. 56. The net loss is "point H - point G" = .90 - .84 = .06 in. wg. This is entered in column 6, Fig. 56. Enter 24 in. diameter in column 9.

- Determine duct size for section 3: Project downward on the 24 in. line to the 10,800 cfm line, point H to I. Project along the guide lines at the right side of the chart from I to the 9600 cfm line at point J. Enter appropriate values from the chart in column 4, 5, 6 and 9 Fig. 56.
- Determine duct sizes for sections 4 thru 10 in a manner similar to Stop 8, using the listed air quantities and equivalent lengths. One exception is duct section 6. Since its equivalent length is 44 feet, use the method outlined in Steps 5, 6 and 7 to determine the pressure drop. In addition, see Example 5, Step 13 and 14, for explanation when the Chart indicates a duct diameter other than those listed, for instance 23 inches.

addition, correction factors for other aspect ratios and insulated duct are given in the notes to the chart.

Example 8 – Calculations for Supply Duct

Given:

- Supply air quantity from load estimate form – 1650 cfm
- Supply duct heat gain from load estimate form – 5%
- Supply duct leakage from load estimate form – 5%
- Unconditioned space temp – 95 F
- Room air temperature – 78 F
- Duct insulation U value – .24
- Duct shown in Fig. 57.

Find:

Air quantities at each outlet

Solution:

$$1. \text{ Room air quantity required at 60 F} = \frac{1650}{1 + .05 + .05} = 1500 \text{ cfm}$$

DUCT HEAT GAIN AND AIR LEAKAGE

Whenever the air inside the duct system is at a temperature different than the air surrounding the duct, heat flows in or out of the duct. As the load is calculated, an allowance is made for this heat gain or loss. In addition, air leakage is also included in the calculated load. The load allowance required and guides to condition under which an allowance should be made for both heat gain or loss and duct should be made for both heat gain or loss and duct leakage are included in Part I, System Heat Gain.

Chart 14 is used to determine the temperature rise or drop for bare duct that has an aspect ratio of 2:1. In

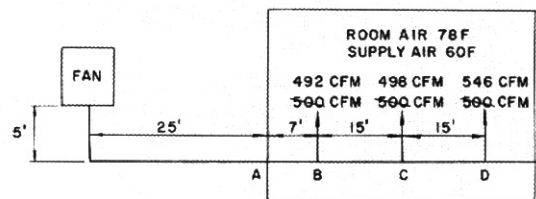

Fig. 57 – Duct Heat Gain and Air Leakage

Normally a 10% leakage allowance is used if the complete duct is outside the room. Since a large portion of the duct is within the room, 5% is used in this example.

- Determine the temperature rise from A to B: Select an initial starting velocity from Table 7 (assume 1400 fmp). Calculate the temperature rise from the fan to the room. Enter Chart 14 at 1500 cfm; project vertically to 1400 fmp and read .27 degrees temperature change per 100 ft per degree F difference. Using aspect ratio of 2:1, temperature rise

$$= \frac{30 \text{ ft}}{100 \text{ ft}} \times .27 \text{ F change} \times 185 \times (95-60) = .52 \text{ F}$$

Air temperature entering room = 60.52 F

Actual air quantity entering room

$$= \frac{78 - 60}{78 - 60.52} \times 1500 = 1540 \text{ cfm}$$

Air temperature rise from A to B

$$= \frac{7}{100} \times 17.48 \times .27 = .33 \text{ F}$$

Supply air temperature diff to outlet B

$$= 78 - (60.52 + .33) = 17.15 \text{ F}$$

Required air quantity to outlet B

$$= 500 \times \frac{18}{17.2} = 522 \text{ cfm}$$

with no allowance for cooling from the duct.

Outlet B cfm with allowance for duct cooling

$$= 500 - \left(1540 \times \frac{.33}{17.2} \right) = 492 \text{ cfm}$$

- Determine cfm for outlet C: Use equal friction method to determine velocity in second section of duct, with 1540 – 492 = 1048 cfm; velocity = 1280 fpm.

Determine temperature rise at outlet: From Chart 14, read .32 for 1280 fpm and 1040 cfm. Temperature rise

$$= .32 \times 17.2 \times \frac{15}{100} = .83 \text{ F}$$

Supply air temperature diff = 17.2 - .8 = 16.4 F

Outlet cfm adjusted for temperature rise

$$= 500 \times \frac{18}{16.4} = 550 \text{ cfm}$$

Allowance for duct cooling

$$= 500 - \left(1048 \times \frac{.8}{16.4} \right) = 498 \text{ cfm}$$

- Determine cfm for outlet D: Use equal friction method to determine velocity in third section of duct with 1048 – 498 = 550 cfm; velocity = 1180 fpm.

Determine temperature rise at outlet:

From Chart 14, read .43 F for 1180 fpm and 550 cfm.

Temperature rise

$$= .43 \times 16.4 \times \frac{15}{100} = 1.06 \text{ F}$$

CHART 14 – DUCT HEAT GAIN OR LOSS

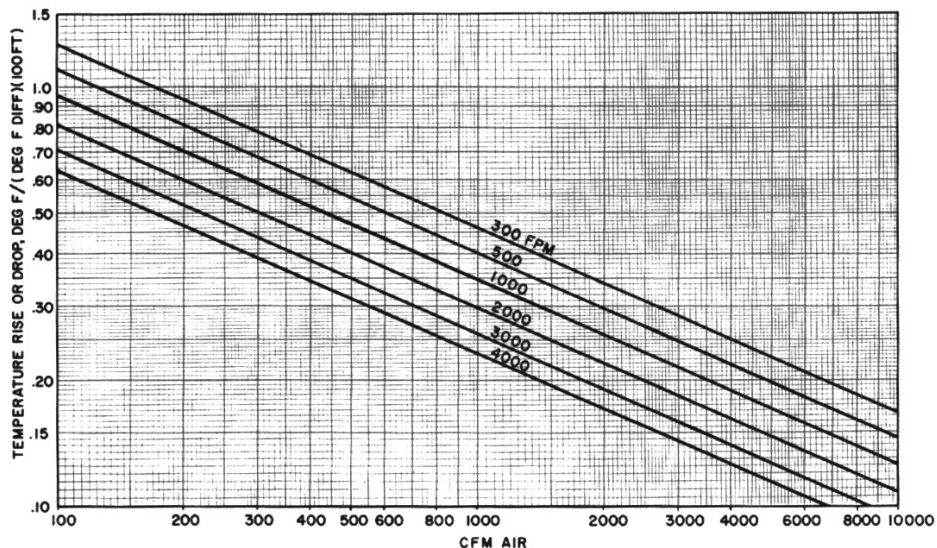

NOTES:

- Based on bare rectangular duct with a 2:1 aspect ratio.

Aspect Ratio	Aspect Ratio Correction									
	Round	1:1	3:1	4:1	5:1	6:1	7:1	8:1	9:1	10:1
Correction	.83	.92	1.1	1.18	1.26	1.35	1.43	1.5	1.58	1.65

- If duct is furred-in or insulated, use the following correction factors:
 - Furred-in duct — .45
 - Insulated (U = .27) — .185
 - Insulated (U = .13) — .10
- For air quantities greater than 10,000 cfm, divide air quantity by 100 and multiply degree change by 0.1.

Supply air temperature diff = 16.4 - 1.1 = 15.3 F

Outlet cfm adjusted for temperature rise

$$= 500 \times \frac{18}{15.3} = 588 \text{ cfm}$$

Allowance for duct cooling

$$= 588 - \left(588 \times \frac{1.1}{15.3} \right) = 546 \text{ cfm}$$

5. Check for total cfm:

$$492 + 498 + 546 = 1536 \text{ cfm}$$

This compares favorably with the 1540 cfm entering room. Fig. 57 shows original and corrected outlet air quantities.

HIGH ALTITUDE DUCT DESIGN

When an air distribution system is designed to operate above 2000 feet altitude, below 30 F, or above 120 F temperature, the friction loss obtained from Chart 7, page 33, must be corrected for the air density. Chart 15 presents the correction factors for temperature and altitude. The actual cfm is used to find the friction loss from Chart 7 and this loss is multiplied by the correction factor or factors from Chart 15 to obtain the actual friction loss.

CHART 15 – AIR DENSITY CORRECTION FACTORS

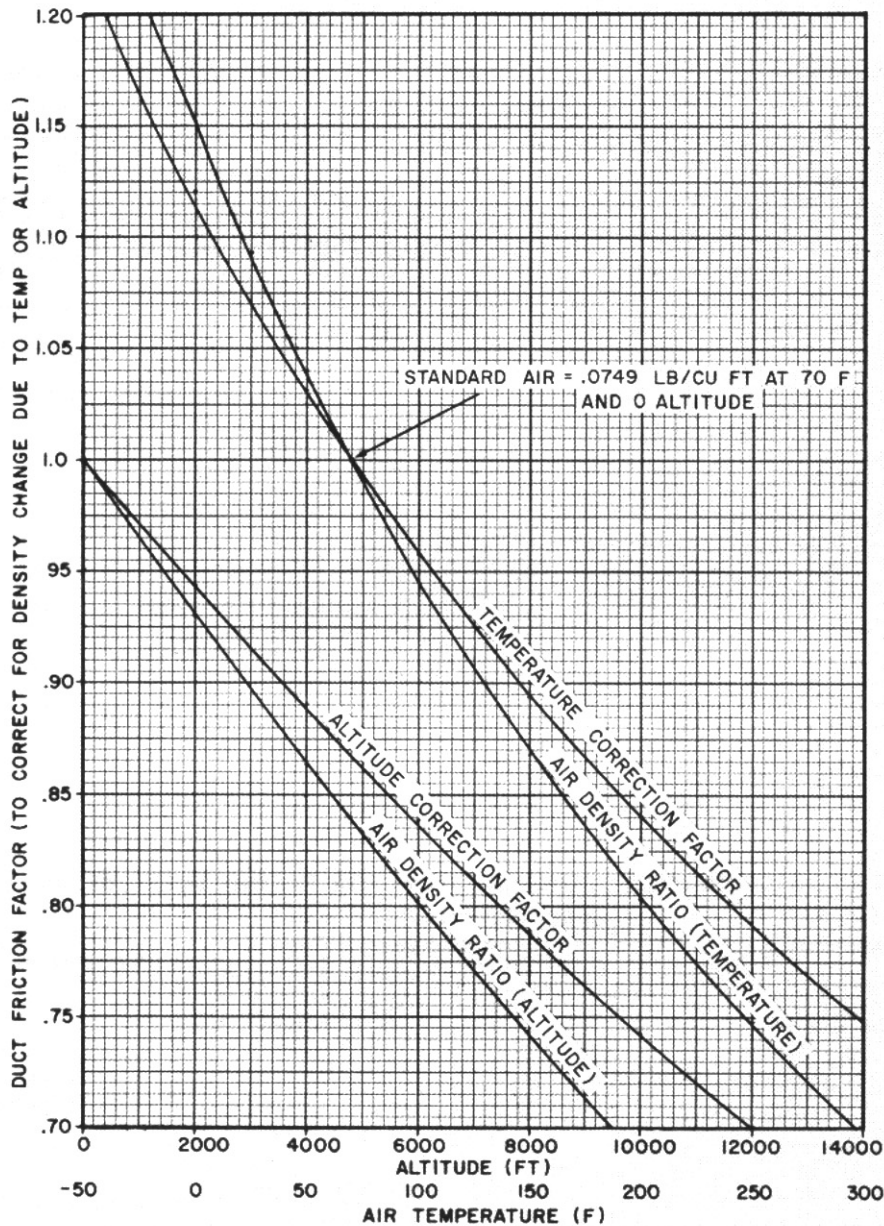

When calculating losses thru filters, cooling coils, heating coils etc., adjust the actual cfm to standard cfm by multiplying by the air density ratio. Obtain the friction loss for the equipment from published data based on the standard cfm. Divide the friction from the published data by the air density ratio to obtain the actual air friction.

DUCT CONSTRUCTION

The sheet metal gage used in the ducts and the reinforcing required depends on the pressure conditions of the system. There is also a wide variety of joints and seams used to form the ducts which also depend on pressure conditions in the duct system.

Low Pressure Systems

Table 14 lists the recommended construction for rectangular ducts made of aluminum or steel.

The method of bracing and reinforcing and types of joints and seams are included in the table. Round duct and Spira- Pipe construction are included in Table 15 and 16 which apply for low and high pressure system. Fig. 58 illustrates the more common seams and joints used in low pressure systems.

TABLE 16 – MATERIAL GAGE FOR SPIRA-PIPE DUCT
Low and High Pressure Systems

DUCT DIMENSION (in.)	DUCT MATERIAL GAGE	
	Steel U.S. Gage	Aluminum B & S Gage
Up to 8	26	22
9 to 24	24	20
26 to 32	22	18

TABLE 14 – RECOMMENDED CONSTRUCTION FOR RECTANGULAR SHEET METAL DUCTS
Low pressure systems

DUCT DIMENSION (in.)	MATERIAL GAGE				RECOMMENDED CONSTRUCTION* Transverse Joints, Bracing and Reinforcing
	Steel U.S. Gage		Aluminum B & S Gage		
	Duct	Slip	Duct	Slip	
Up to 24	24	24	22	20	Pocket slip or Bar-S slip, spaced not more than eight feet apart.
24 to 30	24	24	22	20	
31 to 60	22	22	20	18	
61 to 72	20	20	18	16	Reinforced pocket slip† or reinforced Bar-S†, spaced not more than four feet apart. 1½" x 1½" x ¼" diagonal angle reinforcing‡ or 1½" x 1½" x ¼" girth angle reinforcing‡ located midway between joints.
73 to 90	20	20	18	16	Reinforced pocket slip† or reinforced Bar-S slip† spaced not more than four feet apart. 1½" x 1½" x ¼" diagonal angle reinforcing‡ or 1½" x 1½" x ¼" girth angle reinforcing‡ located midway between joints. ¼" x ¼" band iron stay bracing for duct width 73" to 90".
91 and Up	18	20	16	16	Reinforced pocket slip† or reinforced Bar-S slip† spaced not more than four feet apart. 1½" x 1½" x ¼" diagonal angle reinforcing‡ or 1½" x 1½" x ¼" girth angle reinforcing‡ located midway between joints. ¼" x ¼" band iron stay bracing for duct width 91" to 120". ¼" x ¼" band iron stay bracing spaced 48" apart for duct widths 121" and up.

*All ducts over 18" in either dimension are cross-broken, except those to which rigid board insulation is applied or area of duct where outlet or duct connection is to be installed. Duct seams are either Pittsburgh lock seam or longitudinal seam.

†Reinforce joint with ¼" x ¼" band iron.

‡Angles are attached to duct by tack welding, sheet metal screws, or rivets on 6" centers.

TABLE 15 – RECOMMENDED CONSTRUCTION FOR ROUND SHEET METAL DUCT
Low and High Pressure Systems

DUCT DIMENSION (in.)	MATERIAL GAGE		RECOMMENDED CONSTRUCTION	
	Steel U.S. Gage	Aluminum B & S Gage	Reinforcing	Joints and Seams
Up to 8	24	22	1¼" x 1¼" x ¼" girth angle reinforcing spaced on 8' centers. 1¼" x 1¼" x ¼" girth angle reinforcing spaced on 6' centers. 1½" x 1½" x ¼" girth angle reinforcing spaced on 4' centers.	Round duct sections are joined together by welding, by a coupling, or by bellng out one end of duct. The seams on round duct may be continuous welded or grooved longitudinal seam.
9 to 24	22	20		
25 to 36	20	18		
37 to 48	20	18		
49 to 72	18	16		
73 and Up	16	14		

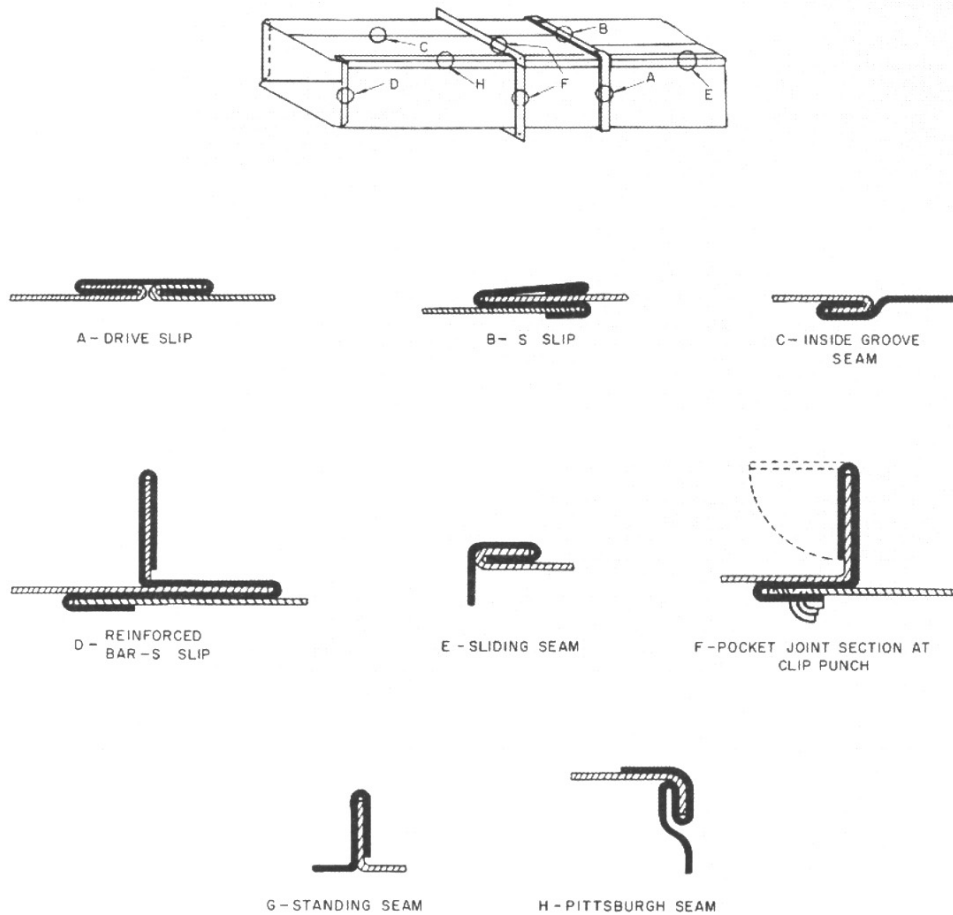

Fig. 58 – Joints and Seams For Low Pressure System

High Pressure Systems

Table 17 contains the construction recommendations for rectangular duct made of aluminum or steel. The table includes the required reinforcing and bracing and types of joints and seams used in high pressure duct systems.

Fig. 59 shows the common joint used for rectangular ducts in high pressure systems. The ducts are constructed with a Pittsburgh lock or grooved longitudinal seams (Fig. 58).

Table 15 shows the recommended duct construction for round ducts. The data applies for either high or low pressure systems. Fig. 60 illustrates the seams and joints used in round duct systems. The duct materials for Spira-Pipe are given in Table 16.

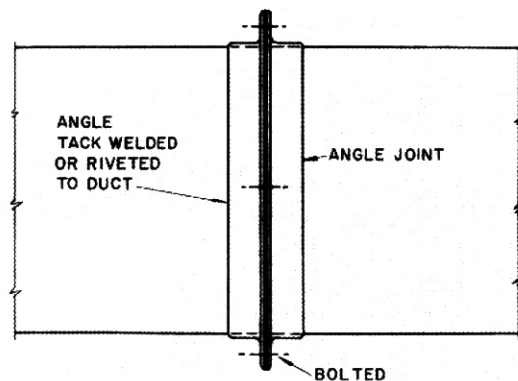

Fig. 59 – Joint For High Pressure System

TABLE 17 – RECOMMENDED CONSTRUCTION FOR RECTANGULAR SHEET METAL DUCTS
High Pressure Systems

DUCT DIM (in.)	MATERIAL GAGE		RECOMMENDED CONSTRUCTION* Transverse Joints Bracing and Reinforcing
	Steel U.S. Gage	Aluminum B & S Gage	
Up to 24	22	20	Flanged angle gasketed joint or butt welded joint with girth angle, spaced not more than twelve feet apart. Angles are 1 1/2" x 1 1/2" x 1/8"†. 1 1/2" x 1 1/2" x 3/16" girth angle reinforcing spaced 38" to 40" apart†.
25 to 48	20	18	
49 to 60	18	16	
61 and Up	18	16	Flanged angle gasketed joint or butt welded joint with girth angle, spaced not more than twelve feet apart. Angles are 1 1/2" x 1 1/2" x 3/16"†. 1 1/2" x 1 1/2" x 3/16" girth angle reinforcing spaced 38" x 40" apart†.

*All ducts over 18" in either dimension are cross-broken except those to which rigid board insulation is applied or area where outlets are installed. Seams are either Pittsburgh lock seam or longitudinal seam.

†Angle are attached to duct by tack welding or rivets on 6" centers.

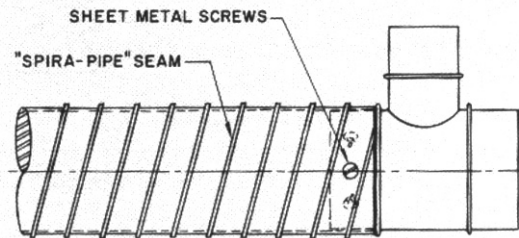

Fig. 61 – Joint and Seam For Spira-pipe

Fittings are normally used to join sections of Spira-Pipe as shown in Fig. 61. Sealing compound is used to join Spira-Pipe to fittings.

WEIGHTS OF DUCT MATERIALS

Table 18 gives the weights of various materials used for duct systems.

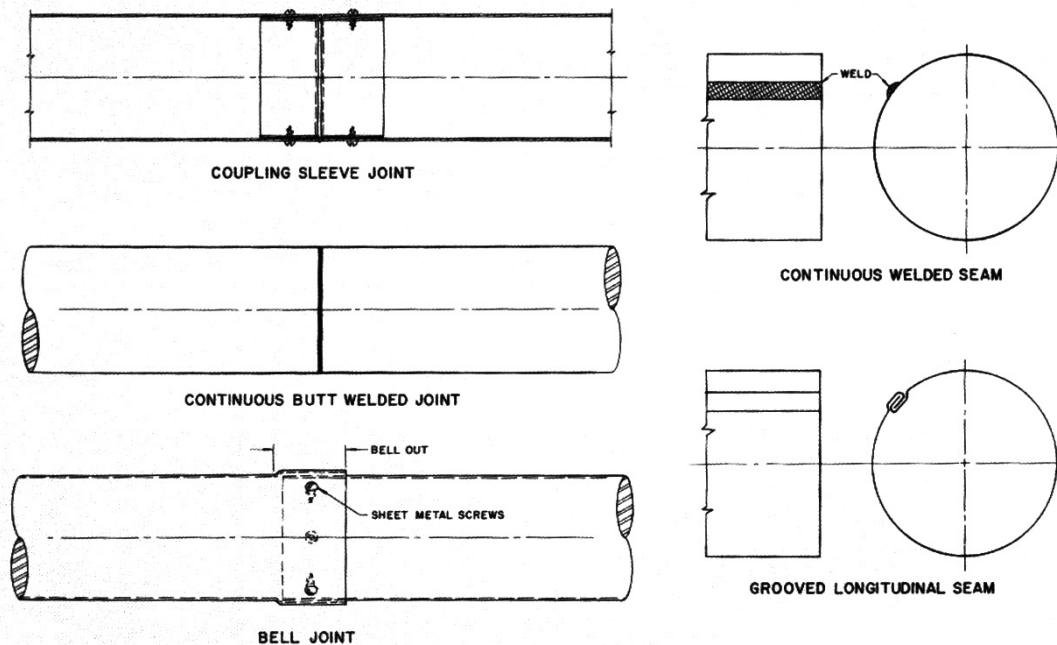

Fig. 60 – Round Duct Joints and Seams

TABLE 18 – WEIGHTS OF DUCT MATERIAL

WEIGHT (lb/sq ft)	GAGE (THICKNESS) (in.)	WEIGHT PER SHEET (lb)		
		36 x 96	48 x 96	48 x 120
GALVANIZED STEEL, U.S. GAGE				
.906	26 ga. (.022)	21.8	29.0	36.2
1.156	24 ga. (.028)	27.7	37.0	46.2
1.406	22 ga. (.034)	33.8	45.0	56.2
1.656	20 ga. (.040)	39.7	53.0	66.2
2.156	18 ga. (.052)	51.6	70.0	86.2
2.656	16 ga. (.064)	63.6	85.0	102.2
3.281	14 ga. (.080)	78.8	105.0	131.2
HOT ROLLED STEEL, U.S. GAGE				
.750	26 ga. (.0179)	18.0	24.0	30.0
1.000	24 ga. (.0239)	24.0	32.0	40.0
1.250	22 ga. (.0299)	30.0	40.0	50.0
1.500	20 ga. (.0359)	36.0	48.0	60.0
2.000	18 ga. (.0478)	48.0	64.0	80.0
2.500	16 ga. (.0596)	60.0	80.0	100.0
3.125	14 ga. (.0747)	78.0	104.0	130.0
5.625	10 ga. (.1345)	135.0	180.0	225.0
ALUMINUM, B & S GAGE (35)				
.288	24 ga. (.020)	6.9	9.2	11.5
.355	22 ga. (.025)	8.6	11.3	14.2
.456	20 ga. (.032)	11.0	14.6	18.2
.575	18 ga. (.040)	13.8	18.4	23.0
.724	16 ga. (.051)	17.4	23.2	29.0
.914	14 ga. (.064)	22.0	29.2	36.6
1.03	12 ga. (.071)	24.7	33.0	41.3
STAINLESS STEEL, U.S. GAGE (302)				
.66	28 ga. (.016)	15.8	21.1	26.4
.79	26 ga. (.019)	18.9	25.2	31.6
1.05	24 ga. (.025)	25.2	33.6	42.0
1.31	22 ga. (.031)	31.5	42.0	52.5
1.58	20 ga. (.038)	37.8	50.4	63.0
2.10	18 ga. (.050)	50.4	61.2	84.0
2.63	16 ga. (.063)	63.0	84.0	105.0
3.28	14 ga. (.078)	78.7	104.9	131.2
COPPER, OZ/SQ FT				
1.00	16 oz. (.0216)	24.0	32.0	40.0
1.25	20 oz. (.027)	30.0	40.0	50.0
1.50	24 oz. (.0323)	36.0	48.0	64.0
2.00	32 oz. (.0432)	48.0	64.0	80.0
2.25	36 oz. (.0486)	54.0	72.0	90.0
2.50	40 oz. (.0540)	60.0	80.0	100.0

CHAPTER 3. ROOM AIR DISTRIBUTION

This chapter discusses the distribution of conditioned air after it has been transmitted to the room. The discussion includes proper room air distribution, principles of air distribution, and types and location of outlets.

REQUIREMENTS NECESSARY FOR GOOD AIR DISTRIBUTION

TEMPERATURE

Recommended standards for room design conditions are listed in *Part 1*, Chapter 2. The air distributing system must be designed to hold the temperature within tolerable limits of the above recommendations. In a single space a variation of 2 F at different locations in the occupied zone is about the maximum that is tolerated without complaints. For a group of rooms located within a space, a maximum of 3 F between rooms is not unusual. Temperature variations are generally more objectionable in the heating season than in the cooling season.

Temperature Fluctuations are more noticeable than temperature variations. These fluctuations are usually a function of the temperature control system. When they are accompanied by air movements on the high end of the recommended velocities, they may result in complaints of drafts.

AIR VELOCITY

Table 19 shows room air velocities. It also illustrates occupant reaction to various room air velocities in the occupied zone.

AIR DIRECTION

Table 19 shows that air motion is desirable and actually necessary. Fig. 62 is a guide to the most desirable air direction for a seated person.

PRINCIPLE OF AIR DISTRIBUTION

The following section describes the principle of air distribution.

BLOW

Blow is the horizontal distance that an air stream travels on leaving an outlet. This distance is measured from the outlet to a point at which the velocity of the air stream has reached a definite minimum 6.5 ft. above the floor.

Blow is proportional to the velocity of the primary air as it leaves the outlet, and is independent of the temperature difference between the supply air and the room air.

TABLE 19 – OCCUPIED ZONE ROOM AIR VELOCITIES

ROOM AIR VELOCITY (fpm)	REACTION	RECOMMENDED APPLICATION
0-16	Complaints about stagnant air	none
25	Ideal design—favorable	all commercial applications
25-50	Probably favorable but 50 fpm is approaching maximum tolerable velocity for seated persons	all commercial applications
65	Unfavorable—light papers are blown off a desk	
75	Upper limit for people moving about slowly—favorable	retail and dept. store
75-300	Some factory air conditioning installations—favorable	factory air conditioning higher velocities for spot cooling

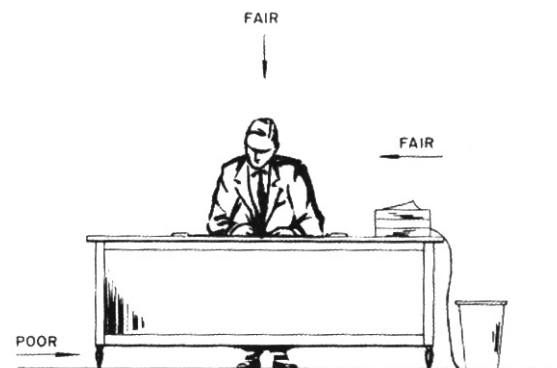

Fig. 62 – Desirable Air Direction

DROP

Drop, or rise, is the vertical distance the air moves between the time it leaves the outlet and the time it reaches the end of its blow.

INDUCTION

Induction is the entrainment of room air by the air ejected from the outlet and is a result of the velocity of the outlet air. The air coming directly from the outlet is called primary air. The room air which is picked up and carried along by the primary air is called secondary air. The entire stream, composed of a mixture of primary and secondary air, is called total air.

Induction is expressed by the momentum equation:

$$M_1 V_1 + M_2 V_2 = (M_1 + M_2) \times V_3$$

Where M_1 = mass of the primary air
 M_2 = mass of the secondary air
 V_1 = Velocity of the primary air
 V_2 = velocity of the secondary air
 V_3 = Velocity of the total air

Induction ratio (R) is defined as the ratio of total air to primary air;

$$R = \frac{\text{total air}}{\text{primary air}} = \frac{\text{primary} + \text{secondary air}}{\text{primary air}}$$

IMPORTANCE OF INDUCTION

Since blow is a function of velocity and since the rate of decrease of velocity is dependent on the rate of induction, the length of blow is dependent on the amount of induction that occurs. The amount of induction for an outlet is a direct function of the perimeter of the primary air stream cross-section. For two outlets having the same area, the outlet with the large perimeter has the greatest induction and, therefore, the shortest blow. Thus, for a given air quantity discharged into a room with a given pressure, the minimum induction and maximum blow is obtained by a single outlet with a round cross-section. Conversely, the greatest induction and the shortest blow occur with a single outlet in the form of a long narrow slot.

SPREAD

Spread is the angle of divergence of the air stream after it leaves the outlet. Horizontal spread is divergence in the horizontal plane and vertical spread is divergence in the vertical plane. Spread is the included angle measured in degrees.

Spread is the result of the momentum law. Fig. 63 is an illustration of the effect of induction on stream area and air velocity.

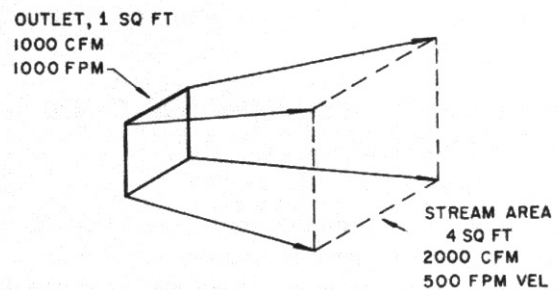

Fig. 63 – Effect of Induction

Example 1 – Effect of induction

Given:

- 1000 cfm primary air
- 1000 cfm secondary air
- 1000 fpm primary air velocity
- 0 fpm secondary air velocity

Find:

The velocity and area of the total air stream when 1000 cfm of primary and 1000 cfm of secondary air are mixed.

Solution:

Area of the initial primary air stream before induction

$$= \frac{M_1}{V_1} = \frac{1000}{1000} = 1 \text{ sq ft}$$

Substituting in the momentum equation

$$(1000 \times 1000) + (1000 \times 0) = (1000 + 1000) V_3$$

$$V_3 = 500$$

Area of the total air stream

$$= \frac{M_1 + M_2}{V_3} = \frac{1000 + 1000}{500} = 4 \text{ sq ft}$$

An outlet discharging air uniformly forward, no diverging or converging vane setting, results in a spread of about an 18° to 20° included angle in both planes. This is equal to a spread of about one foot in every six feet of blow. Type and shape of outlet has an influence on this included angle, but for nearly all outlets it holds to somewhere between 15° and 23°

INFLUENCE OF VANES ON OUTLET PERFORMANCE

Straight Vanes

Outlets with vanes set at a straight angle result in a spread of approximately 19° in both the horizontal and vertical plane (Fig. 64)

Converging Vanes

Outlets with vanes set to direct the discharge air (Fig. 65) result in approximately the same spread (19°) as when the vanes are set straight.

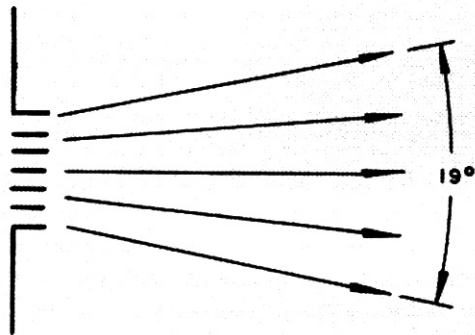

Fig. 64 – Spread with Straight Vanes

However, the resulting blow is approximately 15% longer than the straight vane setting

Diverging Vanes

Outlets with vanes set to give an angular spread to the discharge air have a marked effect on direction and distance of travel. Vertical vanes with the end vanes set at a 45° angle, and all other vanes set at intermediate angles to give a fanning effect, produce an air stream with a horizontal included angle of approximately 60° (Fig. 66). Under this condition the blow is reduced about 50%. Outlets with end vanes set at angles less than 45° , and all other vanes set at intermediate angles to give a fanning effect, have a blow correspondingly larger than the 45° vane setting, but less than a straight vane setting.

Where diverging vanes are used, the free outlet area is reduced; therefore, the air quantity is less than for straight vanes unless the pressure is increased. To miss an obstruction or to direct the air in a particular direction, all vanes can be set for a specific angle as illustrated in Fig. 67. Notice that the spread angle is still approximately 19° .

INFLUENCE OF DUCT VELOCITY ON OUTLET PERFORMANCE

An outlet is designed to distribute air that has been supplied to it with velocity, pressure and direction, with limits that enable it to completely perform its function. However, an outlet is not designed to correct unreasonable conditions of flow in the air supplied to it.

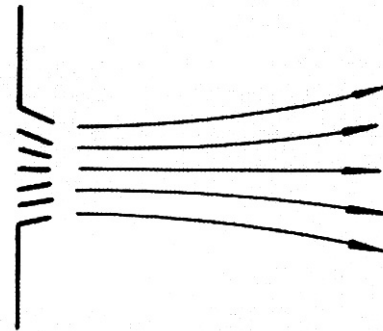

Fig. 65 – Spread with Converging Vanes

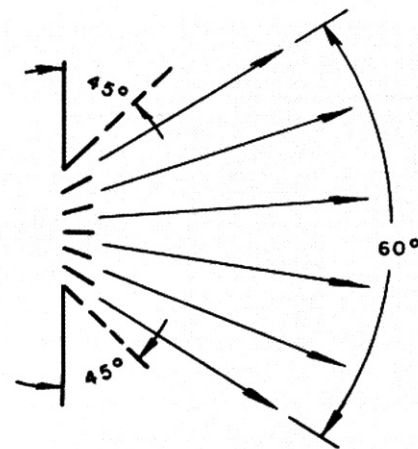

Fig. 66 – Spread with Diverging Vanes

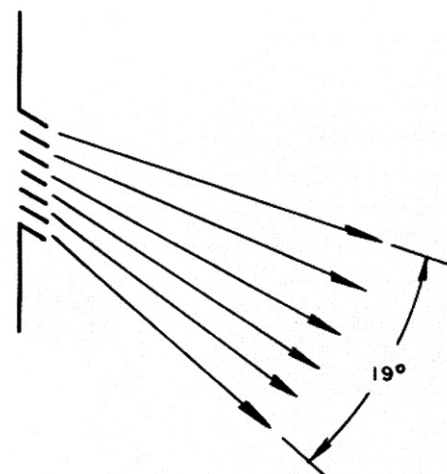

Fig. 67 – Spread with Straight Vanes Set At An Angle

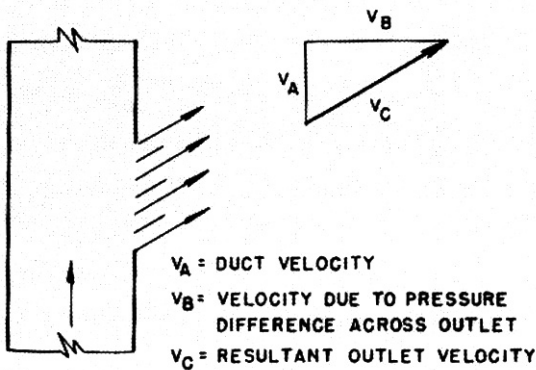

Fig. 68 – Outlet Located in Duct

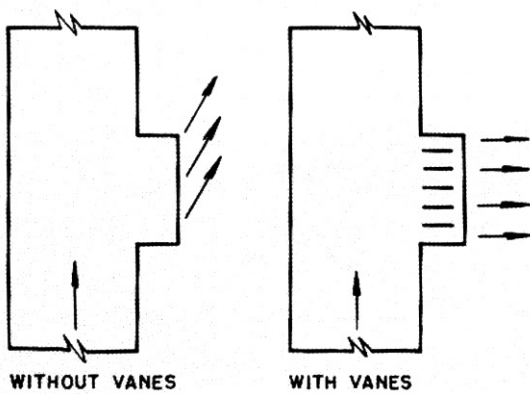

Fig. 69 – Collar for Outlets

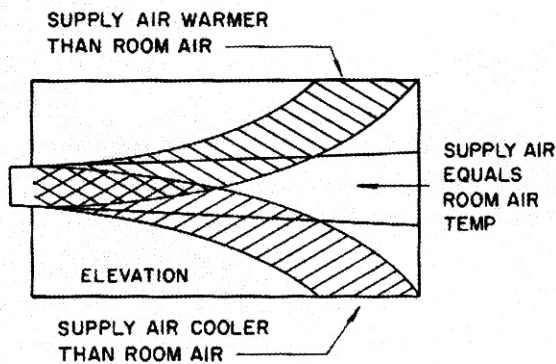

Fig. 70 – Air Stream Patterns for Various Temperature Differentials

Where an outlet without vanes is located directly against the side of a duct, the direction of blow of the air from the outlet is the vector sum of the duct velocity and the outlet velocity (Fig. 68). This may be modified by the peculiarity of the duct opening.

Where an outlet is applied to the face of the duct, the resultant velocity V_c can be modified by adjustable vanes behind the outlet. Whether they should be applied or not depends on the amount of divergence from straight blow that is acceptable.

Often outlets are mounted on short extension collars away from the face of the duct. Whenever the duct velocity exceeds the outlet discharge velocity, vanes should be used where the collar joins the duct. Results are indicated in Fig. 69.

IMPORTANCE OF CORRECT BLOW

Normally it is not necessary to blow the entire length or width of a room. A good rule of thumb to follow is to blow $\frac{3}{4}$ of the distance to the opposite wall. Exceptions occur, however, when there are local sources of heat at the end of the room opposite the outlet. These sources can be equipment heat and open doors. Under these circumstances, over blow may be required and caution must be exercised to prevent draft conditions.

SUPPLY TEMPERATURE DIFFERENTIAL

The allowable supply temperature difference that can be tolerated between the room and the supply air depends to great extent on (1) outlet induction ratio, (2) obstructions in the path of the primary air, and (3) the ceiling height. Fig. 70 indicates the effect of changing the supply air temperature from warm to cold.

Since induction depends on the outlet velocity, there is a supply temperature differential which must be specified to give satisfactory results.

TOTAL ROOM AIR MOVEMENT

The object of room air distribution is to provide satisfactory room air motion within the occupied zone, and is accomplished by relating the outlet characteristics and performance to the room air motion as follows:

1. Total air in circulation
= outlet cfm X induction ratio.
2. Average room velocity
= $\frac{1.4 \times \text{total cfm in circulation}}{\text{area of wall opposite outlet(s)}}$
3. K = $\frac{\text{average room velocity}}{1.4 \times \text{induction ratio}}$
= $\frac{\text{outlet cfm}}{\text{clear area of wall opposite outlet (s)}}$

Where K is the room circulation factor expressed in primary air cfm/sq of wall opposite the outlet.

The multiplier 1.4 allows for the blocking caused by the air stream. Note that the clear wall area is indicated in the equation and all obstruction must be deducted. See Note 8, Table 21.

Table 19 indicates that the average room air movement should be kept between 15 and 50 fpm for most applications. Tests have been performed on outlets at various outlet velocities to determine performance characteristics. The results of such tests on a specific series of wall outlets (Fig. 93) are shown in the rating tables at the end of this chapter. This rating data can be successfully used for outlets having the nominal dimensions and free area indicated in Table 21. An example illustrating outlet selection accompanies the table. The K factor as indicated in Item 3 is shown at the bottom of the rating table as maximum and minimum cfm/sq ft of outlet wall area.

TYPES OF OUTLETS

PERFORATED GRILLE

This grille has a small vane ratio (usually from 0.05 to 0.20) and, therefore, has little directional effect. Consequently, it is used principally as an exhaust or return grille but seldom as a supply grille. When a manual shut-off damper backs up this grille, it becomes a register.

FIXED BAR GRILLE

The fixed bar grille is used satisfactorily in locations where flow direction is not critical or can be predetermined. A vane ratio of one or more is desirable. To obstruct the line of sight into the duct interior, closely spaced vanes are preferred.

ADJUSTABLE BAR GRILLE

This grille is the most desirable for side wall location. Since it is available with both horizontal and vertical adjustable bars, minor air motion problems can be quickly corrected by adjusting the vanes.

SLOTTED OUTLET

This outlet may have multiple slots widely spaced, resulting in about 10% free area. Performance is about the same as for a bar grille of the same cfm and static pressure, but the blow is shorter because of greater induction at the outlet face.

Another design to effect early completion of induction is the long single, or double, horizontal slot.

It is particularly advantageous where low ceiling heights exist and outlet height is limited, or where objections to the appearance of grilles are raised.

EJECTOR OUTLET

The ejector outlet operates at a high pressure to obtain a high induction ratio and is primarily used for industrial work and spot cooling. When applied to spot cooling, a high degree of ejector flexibility is desired.

INTERNAL INDUCTION OUTLET

Where a sufficiently high air pressure is used, room air is induced thru auxiliary openings into the outlet. Here it is mixed with primary air, and discharged into the room at a lower temperature differential than the primary stream. Induction progresses in two steps, one in the outlet casing and the other after the air leaves the outlet.

CEILING OUTLETS

Pan Outlet

This simple design of ceiling distribution makes use of a duct collar with a pan under it. Air passes from the plenum thru the duct collar and splashes against the pan. The pan should be of sufficient diameter to hide the duct opening from sight, and also should be adjustable in distance from the ceiling. Pans may be perforated to permit part of the air to diffuse downward. Advantages of the pan outlet are low cost and ability to hide the air opening. Disadvantages are lack of uniform air direction because of poor approach conditions and the tendency to streak ceilings.

Ceiling Diffuser

These outlets are improvements over the pan type. They hasten induction somewhat by supplying air in multiple layers. Approach conditions must be good to secure even distribution. Frequently they are combined with lighting fixtures, and are available with an internal induction feature. See Fig. 71.

Perforated Ceilings and Panels

Various types of perforated ceilings for the introduction of conditioned air for comfort and industrial systems are available. The principal feature of this method of handling air is that a greater volume of air per square foot of floor area can be introduced at a lower temperature, with a minimum of movement in the occupied zone and with less danger of draft. Since discharge velocity is low, induction is low. Therefore, care must be taken to provide adequate room air motion in excess of 15 fpm.

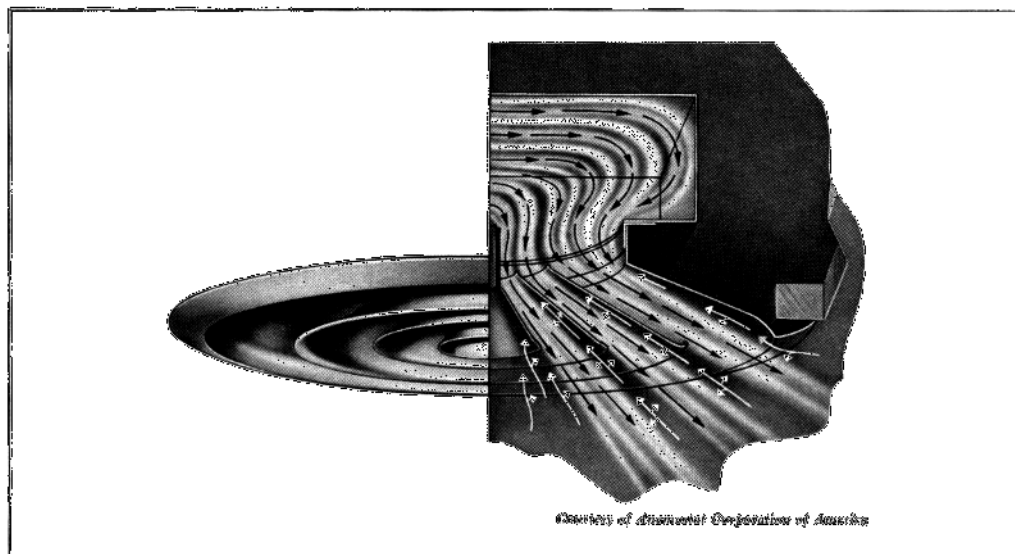

Fig. 71 – Internal Induction Ceiling Diffuser

Duct designed for a perforated ceiling is the same as duct designed for a standard ceiling. To obtain adequate supply to all areas, the same care necessary for conventional systems must be taken in laying out ducts for the perforated ceiling. The ceiling panels should not be depended upon to obtain proper air distribution, since they cannot convey air to areas not otherwise properly supplied. Perforated panels do assist in “spreading out” the air supply and, therefore, comparatively large temperature differentials may be used, even with low ceiling heights.

APPLICATION OF CEILING DIFFUSERS

Installations using ceiling diffusers normally result in fewer complaints of drafts than those using side wall terminals. To eliminate or minimize these complaints, the following recommendations should be considered when applying ceiling diffusers.

BLOW

Select ceiling diffusers for a conservative blow, generally not over 75% of the tabulated value. Over blow may cause problems on many installations; under-blow seldom does.

PRESSURE DROPS

Most rating tables express the pressure drop thru the outlet only and do not include the pressure drop necessary to force the air out of the duct thru the collar and outlet and into the room. Therefore, it is

recommended that rated pressure drops be carefully investigated and the proper safety factor applied when necessary.

DIFFUSER APPROACH

An important criterion for good diffuser performance is the proper approach condition. This means either a collar of at least 4 times the duct diameter, or good turning vanes. If vanes are used, they must be placed perpendicular to the air flow at the upper end of the collar and spaced approximately 2 in. apart.

OBSTRUCTIONS

Where obstructions to the flow of air from the diffuser occur, blank off a small portion of the diffuser at the point at which the obstruction is located. Clip-on baffles are usually provided for this purpose.

OUTLET NOISE LIMITATIONS

One important criterion affecting the choice of an outlet is its sound level. Table 20 shows recommended outlet velocities that result in acceptable sound levels for various types of applications.

OUTLET LOCATIONS

Interior architecture, building construction and dirt streaking possibilities necessarily influence the layout and location of the outlet. However desirable it may be to locate an outlet in a given spot, these items may prevent such location.

TABLE 20 – RECOMMENDED OUTLET VELOCITIES

APPLICATION	TERMINAL VELOCITY (FPM)
Broadcast studios	300-500
Residences	500-750
Apartments	500-750
Churches	500-750
Hotel bedrooms	500-750
Legitimate theaters	500-750
Private offices, acoustically treated	500-750
Private offices, not treated	500-800
Motion picture theaters	1000
General offices	1000-1250
Dept. stores, upper floors	1500
Dept. stores, main floor	2000

After all the foregoing limitations have been successfully dealt with, the air distribution principles

which relate to flow, drop, capacity and room air circulation create further limitations in designing an acceptable air distribution system. These are tabulated in the rating tables at the end of the chapter.

Local loads due to people concentration, equipment heat, outside walls and window locations frequently modify the choice of outlet location. The downdraft from a cold wall or a glass window (Fig. 72) can reach velocities of over 200 fpm, causing discomfort to occupants. Unless this downdraft is overcome, complaints of cold feet result. In northern climates this is accomplished by supplementary radiation, or by an outlet located under a window as illustrated in Fig. 73.

Another item to consider when choosing an outlet location is the radiant effect from cold or warm surfaces. During the heating season an outlet discharging warm air under a cold window raises the surface temperature and reduces the feeling of discomfort.

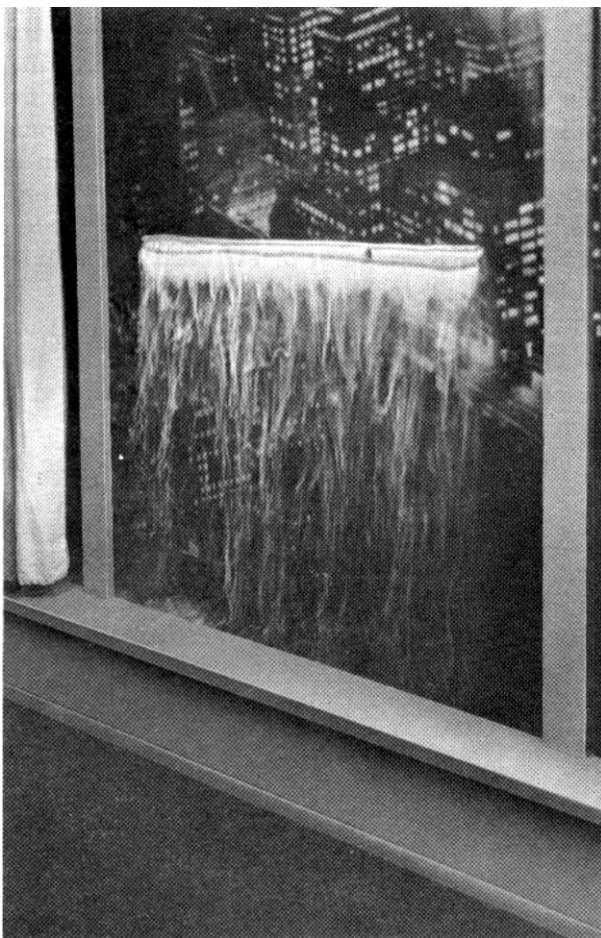

Fig. 72 – Downdraft from Cold Window

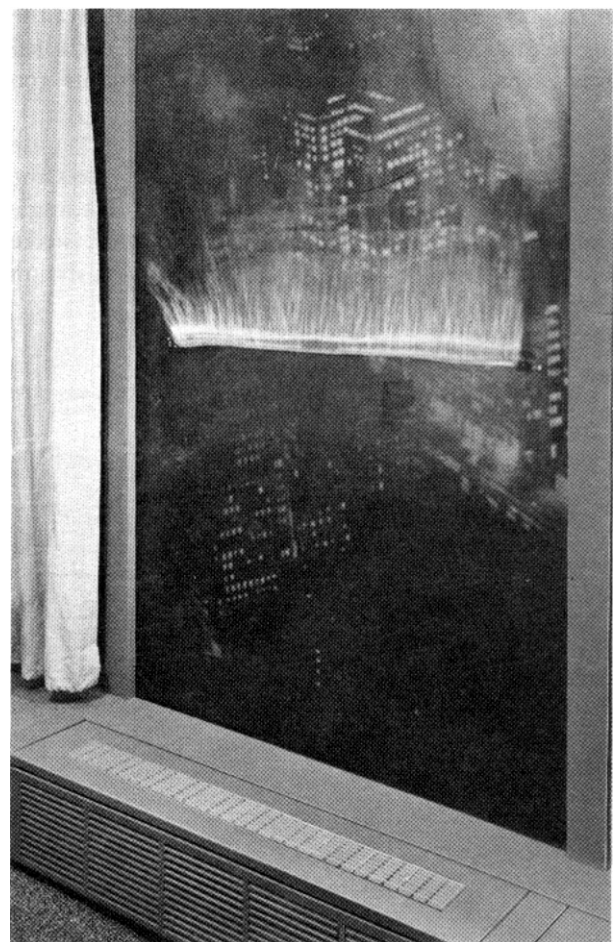

Fig. 73 – Discharge Air Offsetting Window Downdraft

The following describe four typical applications of specific outlet types.

CEILING DIFFUSERS

Ceiling diffusers may be applied to exposed duct, furred duct, or duct concealed in a ceiling. Although wall outlets are installed on exposed and furred duct, they are seldom applied to blow directly downward unless complete mixing is accomplished before the air reaches the occupied zone.

WALL OUTLETS

A high location for wall outlets is preferred where a ceiling is free from obstructions. Where beams are encountered, move the outlet down so that the air stream is horizontal and free from obstruction. If this is not done and if vanes are used to direct the air stream downward, the air enters the occupied zone at an angle and strikes the occupants too quickly. This is shown in Fig. 74.

Wall outlets located near the floor (Fig. 75) are suitable for heating but not for cooling, unless the air is directed upward at a steep angle. The angle must be such that either the air does not strike occupants directly or the secondary induced stream does not cause an objectionable draft.

WINDOW OUTLETS

Where single glass is used, window outlets are preferred to either wall or ceiling distribution to offset the pronounced downdraft during the winter. The air should be directed with vanes at an angle of 15° or 20° from the vertical into the room.

FLOOR OUTLETS

Where people are seated as in a theater, floor outlet distribution is not permissible. Where people are walking about, it is possible to introduce air at the floor level ; for

example, in stores where air is directed horizontally thru a slot under a counter. In this application, however, a very low temperature differential of not more than 5 or 6 degrees must be used. Maintaining this maximum is usually uneconomical because of the large air volume required. However, if air is directed upward behind the counter and diffused at an elevation above the occupied zone, the temperature differential may be increased approximately 5 times. Another disadvantage is that floor outlets become dirt collectors.

SPECIFIC APPLICATIONS

If the principles described in the previous paragraphs are properly applied, problems after installation will be at a minimum. Basically, the higher the ceiling the fewer the number of problems encountered, and consequently liberties may be taken at little or no risk when designing the system. However, with ceiling heights of approximately 12 feet or less, greater care must be exercised to minimize problems.

Experience has shown that ceiling diffusers are easier to apply than side wall outlets, and are preferred when air quantities approach 2 cfm/sq ft of floor area.

The following general remarks about specific applications are the result of thousands of installations and are offered as a guide for better air distribution. Apartments, hotels and office buildings are discussed un relation to specific location of sources of air supply common to these types of buildings. Banks, restaurants, and department and specialty stores are discussed in more general terms, although the common sources of locations of outlets previously discussed can be applied.

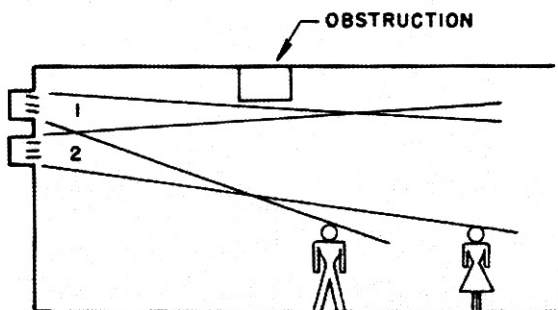

AIR STREAM 2 HAS A LONGER EFFECTIVE BLOW THAN AIR STREAM 1

Fig. 74 – Wall Outlet in Room With Ceiling Obstruction

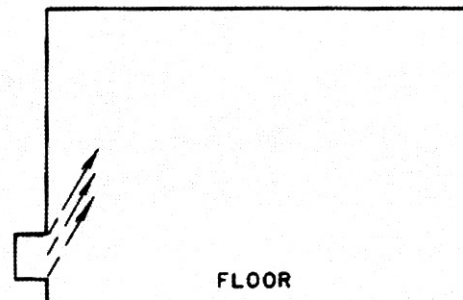

Fig. 75 – Wall Outlet Near Floor

APARTMENTS, HOTELS AND OFFICE BUILDINGS

1. Corridor Supply – No direct radiation (Fig. 76):
 Advantage – Low cost.
 Disadvantage – Very poor in winter. Downdraft under the window accentuated by the outlet blow.
 Precaution – Blow must be not more than 75 % of the room length.
2. Corridor Supply – Direct radiation under windows (Fig. 77):
 Advantage – Offset of downdraft under window in winter when the heat is on.
 Disadvantage – Slight downdraft still occurs during intermediate season or whenever radiation is shut off during cool weather.
 Precaution – Do not blow more than 75 % of room length.
3. Duct above window blowing toward corridor (Fig. 78):
 Advantage – Somewhat better than corridor distribution but does not prevent winter downdraft unless supplemented by direct radiation.
 Disadvantage – Nearly as expensive (considering building alterations) as window outlet which results in better air distribution.
4. Window outlet (Fig. 79):
 Advantage – Eliminates winter downdraft – by far the best method of distribution.
 Disadvantage – May not be economical for multiple windows.
5. Return grille:
 Where return air thru the corridor is permissible and return ducts are not used, it is necessary to use relief grilles or to undercut office doors.

In apartments and hotels, codes must be checked before using the corridor, as a return plenum. Even if codes permit, it is not good engineering practice to use the corridor as a return plenum.

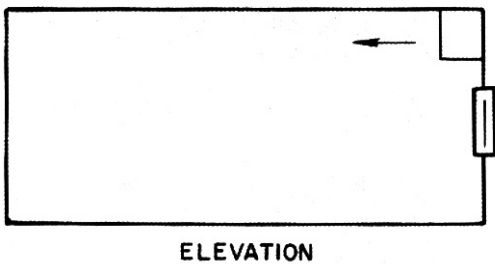

Fig. 76 – Corridor Air Supply

BANKS (FIG. 80)

Often the center bank space has a high ceiling with an electrical load. In this case, use of side wall outlets part of the way up the wall may result in segregating some of the ceiling load and keeping it out of the occupied zone, thus permitting some reduction in cooling load. This location of outlets part way up the wall is used with ceiling heights in excess of 20 ft.

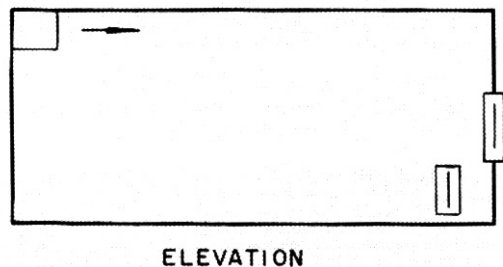

Fig. 77 – Corridor Air Supply with Direct Radiation

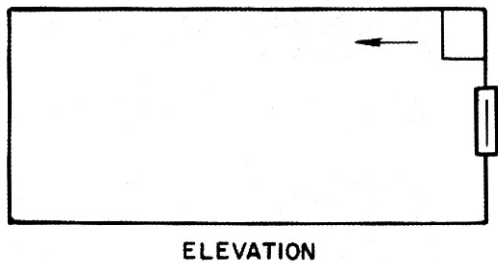

Fig. 78 – Duct Above Window, Blowing Toward Corridor

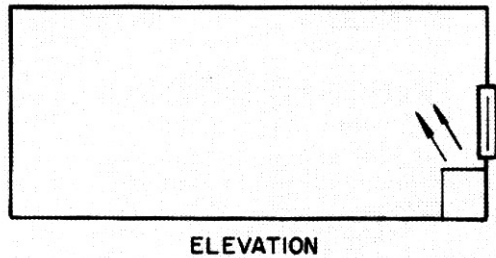

Fig. 79 – Window Outlet

DEPARTMENT STORES (FIG. 81)

There is nothing critical about air distribution in department stores if ordinary precautions are observed, provided the ceiling is high enough. Care should be taken in conditioning a mezzanine since the outlet is likely to over blow and not cool its occupants. Longitudinal distribution is preferred. Basements may give trouble due to low ceilings and pipe obstructions. Main floors usually require more air near doors.

RESTAURANTS (FIG. 82)

Great care must be taken in locating outlets with respect to exhaust hoods or kitchen pass-thru windows. Usually the air velocities over such openings are low and excessive disturbance due to direct blow or induction from outlets may pull air out of them into the conditioned space.

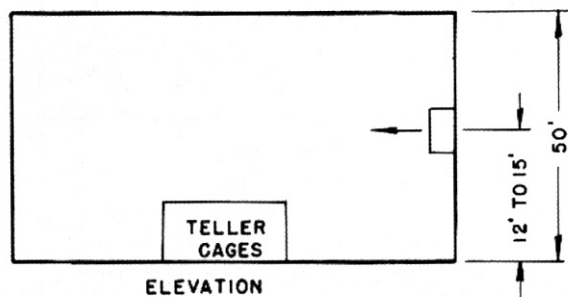

Fig. 80 – Air Distribution with High Ceiling

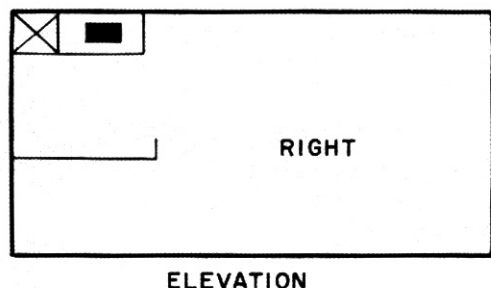
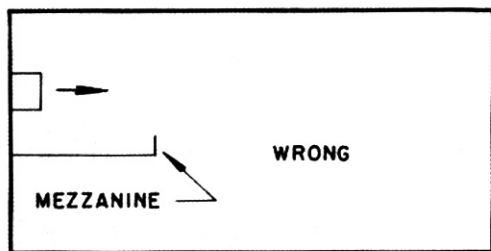
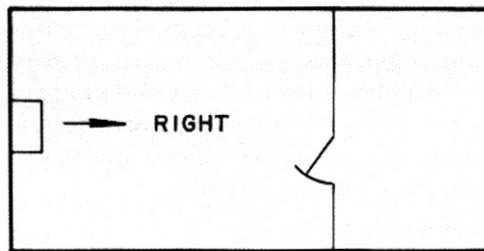
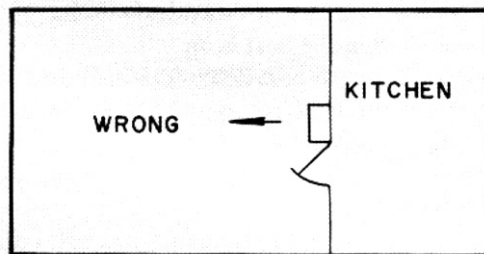

Fig. 81 – Mezzanine Air Distribution

STORES

1. Outlets at rear blowing toward door (Fig. 83):
 Requirements – Unobstructed ceiling.
 Disadvantage – May result in high room circulation factor K.
 Precaution – Blow must be sized for the entire length of the room; otherwise a hot zone may occur due to infiltration at the doorway. Care must be taken to avoid downdrafts near walls.
2. Outlets over door blowing toward rear (Fig. 84):
 Requirements – Unobstructed ceiling.
 Disadvantage – May result in high room circulation.
 Precaution - Excessive infiltration may occur due to induction from doorway.



PLAN

Fig. 82 – Restaurant Air Distribution

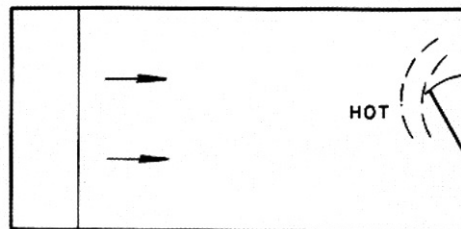

PLAN

Fig. 83 – Air Distribution from Rear of Store

3. Outlets blowing from each end toward center (Fig. 85):
 Advantage – Moderate room circulation.
 Precaution – There may be a downdraft in the center. Outlets should be sized for blow not greater than 40 percent of the total length of the room.
4. Center outlets blowing toward each end (Fig. 86):
 Advantage – Moderate room circulation.
5. Duct along side wall blowing across the store (Fig. 87):
 Advantage – Moderate room circulation.
 Precaution – Over blow may cause downdrafts on the opposite wall.
6. Ceiling diffusers (Fig. 88):
 Requirements – Necessary where ceiling is badly cut up.
 Advantage – best air distribution.
 Disadvantage – High cost.

THEATERS

1. Ejector system for small theaters, no balcony (Fig. 89):
 Requirements – Unobstructed ceiling and ability to locate outlets in the rear wall.
 Advantage – Low cost.
 Precaution – Possibility of dead spots at front and back of theater. Use mushroom for return air under seats if excavated. In northern climates direct radiation may be advisable along the sides.

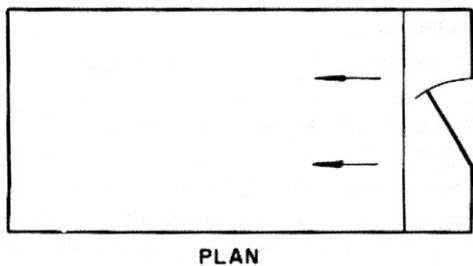

Fig. 84 – Air Distribution from Over the Door

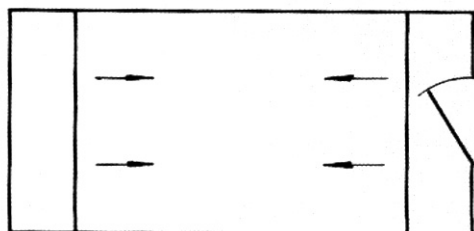

Fig. 85 – Air Distribution from Each End of Store

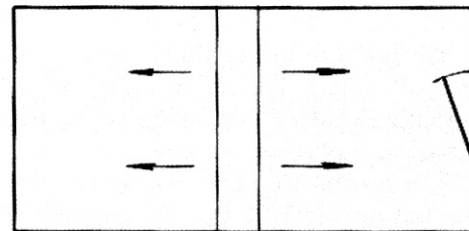

Fig. 86 – Air Distribution from Center of Store

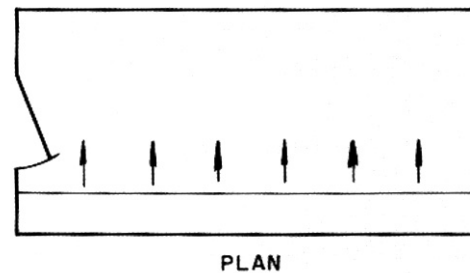

Fig. 87 – Air Distribution from Sidewall Outlets

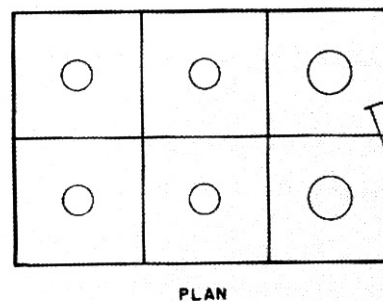

Fig. 88 – Air Distribution from Ceiling Diffusers

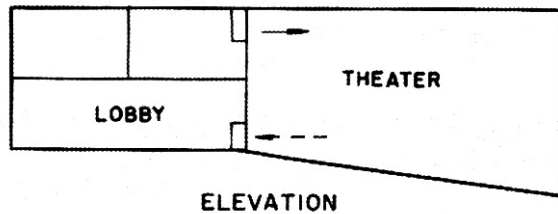

Fig. 89 – Air Distribution for Small Theatres

2. Ejector system for large theaters with balcony (Fig. 90):
 Requirements – Unobstructed ceiling.
 Advantage – Low cost.
 Precaution – Balcony and orchestra should have separate returns. Preferred location, under seats; acceptable location, along sides or rear of theater. Return at front to theater generally not acceptable. Outlets under balcony should be sized for distribution and blow to cover only the area directly beneath the balcony. Orchestra area under balcony should be conditioned by the balcony system. Allow additional outlets in rear for standees when necessary.
3. Overhead system (Fig. 91):
 Requirements – Necessary when ceiling is obstructed.
 Advantage – Complete coverage, no dead spots.
 Disadvantage – Higher first cost.

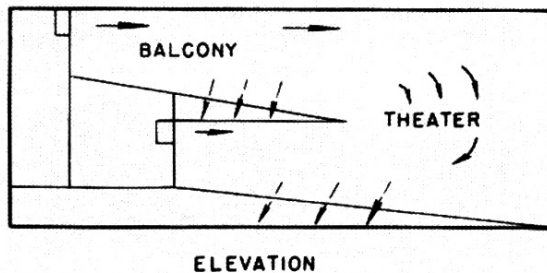

Fig. 90 – Air Distribution for Large Theatres With Balcony

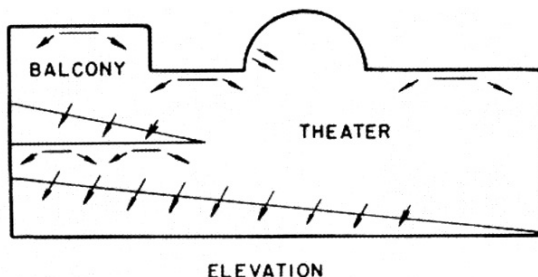

Fig. 91 – Overhead Air Distribution

Precaution – Air must not strike obstructions with a velocity force that causes deflection and drafts in the occupied zone. Temperature differentials must be limited in regions of low ceiling heights. Use low outlet velocities.

RETURN GRILLES

Velocities thru return grilles depend on (1) the static pressure loss allowed and (2) the effect on occupants or materials in the room.

In determining the pressure loss, computations should be based on the free velocity thru the grille, not on the face velocity, since the orifice coefficient may approach 0.7.

In general the following velocities may be used:

GRILLE LOCATION	FPM OVER GROSS AREA
Commercial	
Above occupied zone	800 and above
Within occupied zone not near seats	600-800
Within occupied zone near seats	400-600
Door or wall louvers	500-1000
Undercutting of doors	600*
Industrial	800 and above
Residential	400

*Thru undercut area

LOCATION

Even though relatively high velocities are used thru the face of the return grille, the approach velocity drops markedly just a few inches in front of the grille. This means that the location of a return grille is much less critical than a supply grille. Also a relatively large air quantity can be handled thru a return grille without causing drafts. General drift toward the return grille must be within acceptable limits of less than 50 fpm; otherwise complaints resulting from drafts may result. Fig. 92 indicates the fall-off in velocity as distance from the return grille is increased. It also illustrates the approximate velocities at various distances from the grille, returning 500 cfm at a face velocity of 500 fpm.

Ceiling Return

These returns are not normally recommended. Difficulty may be expected when the room circulation due to low induction is insufficient to cause warm air to flow to the floor in winter. Also, a poorly located ceiling return is likely to bypass the cold air in summer or warm air in winter before it has time to accomplish its work.

Wall Return

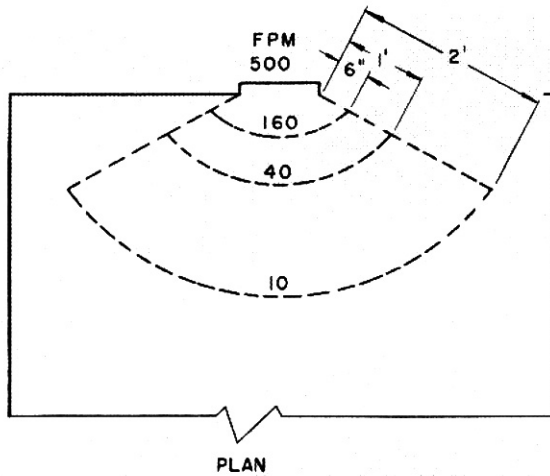

Fig. 92 – Velocity Fall-off per Distance From Grille

A wall return near the floor is the best location. Wall returns near the ceiling are almost as undesirable as ceiling returns. Differences due to poor mixing in the winter are counteracted by a low return since the cool floor air is withdrawn first and is replaced by the warmer upper air strata.

Floor Return

These should be avoided wherever possible because they are a catch-all for dirt and impose a severe strain both on the filter and cooling coils. Whenever floor returns are used, a low velocity settling chamber should be incorporated.

OUTLET SELECTION

The following example describes a method of selecting a wall outlet using the rating tables on page 78.

Example 2 – Wall Outlet Selection

Given:

- Small store
- Dimensions – 32 ft X 23 ft X 16 ft

- Ceiling – flat
- Load – equally distributed
- Air quantity – 2000 cfm
- Temp diff – 25 F

Find:

- Number – of outlets
- Size of outlets
- Location

Solution:

First, find the required blow in feet and the wall outlet area (air movement K factor). The minimum blow is 75% of the room width for the given condition of equally distributed heat load. Therefore, the minimum blow necessary is ¾ X 23 = 17.3 ft. The maximum blow is the width of the room. The outlet wall area K factor is equal to the cfm supplied divided by the outlet wall area:

$$\frac{2000}{32 \times 16} = 3.9 \text{ primary air cfm/sq ft wall area}$$

Enter Table 21 and select one or more outlets to give a blow of at least 17.3 ft. Air movement must be such that the value of K equals 3.9 primary air cfm/sq ft and that this value falls within the maximum and minimum values which are shown at the bottom of the rating tables. The tables indicate that, to best satisfy conditions, four outlets, nominal size 24 in. x 6 in., are to be used. By interpolating, it is found that the four 24 in. x 6 in. outlets at 500 cfm have a range in blow of 17.5 to 34 ft. By adjusting the vanes the proper blow can be obtained. Also the velocity of the outlet is found to be about 775 fpm. This is well within the recommended maximum velocity of 1500 fpm, Table 20. The minimum ceiling height from the table is just over 9 ft. This is less than the height of the room; therefore, the outlet selection is satisfactory. The top of the outlets should be installed at least 12 in. from the ceiling, (Note 8, Table 21).

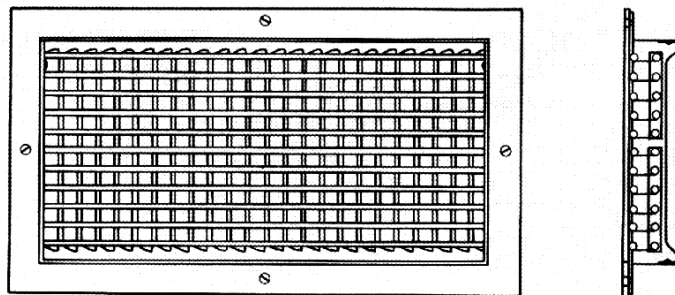

Fig. 93 – Wall Outlet on Which Ratings Are Based

TABLE 21 – WALL OUTLET RATINGS, FOR COOLING ONLY
For Flat Ceilings

OUTLET VELOCITY		250 FPM				375 FPM				500 FPM				750 FPM							
STATIC PRESSURE STANDARD OUTLET		Str B = .01, 22½° = .01 45° = .01				Str B = .013, 22½° = .015 45° = .019				Str B = .024, 22½° = .028 45° = .035				Str B = .051, 22½° = .061 45° = .08							
STATIC PRESSURE WITH METERING PLATE		Str B = .01, 22½° = .015 45° = .028				Str B = .024, 22½° = .043 45° = .065				Str B = .061, 22½° = .082 45° = .118				Str B = .175, 22½° = .19 45° = .27							
Nom. Size of Outlet (and Free Area)	Vane Setting	Air Quantity (cfm)	Blow (ft)	Temp Diff (F)				Air Quantity (cfm)	Blow (ft)	Temp Diff (F)				Air Quantity (cfm)	Blow (ft)	Temp Diff (F)					
				15	20	25	15			20	25	15	20			25					
				Min Clg Ht						Min Clg Ht						Min Clg Ht					
8 x 4 (16.9)	Straight 22½° 45°	30	3.5	6.5	7.0	7.0	44	7.0	7.5	7.5	8.0	59	10.0	7.5	8.0	8.5	89	17.0	8.5	9.0	9.0
			2.5	6.5	6.5	6.5		5.1	6.5	7.0	7.0		7.5	7.5	7.5	13.0		7.5	7.5	8.0	9.0
10 x 4 (21.7)	Straight 22½° 45°	37	3.5	6.5	7.0	7.5	57	7.4	7.5	7.5	8.0	75	10.5	7.5	8.0	8.5	112	18.0	8.5	9.0	9.0
			2.5	6.5	6.5	7.0		5.5	6.5	7.0	7.0		8.0	8.0	8.0	13.0		7.5	8.0	8.0	9.0
12 x 4 (24.6)	Straight 22½° 45°	44	3.5	6.5	7.0	7.5	68	7.5	7.5	7.5	8.0	91	11.0	8.0	8.0	8.5	136	18.0	8.5	9.0	9.5
			2.5	6.5	6.5	7.0		5.5	7.0	7.0	7.5		8.0	8.0	13.0	7.5		8.0	8.5	9.0	6.5
16 x 4 (35.9)	Straight 22½° 45°	61	3.7	7.0	7.0	7.5	92	7.9	7.5	7.5	8.0	122	11.0	8.0	8.0	8.5	183	19.0	8.5	9.0	9.5
			2.7	6.5	6.5	7.0		6.0	7.0	7.0	7.5		8.0	8.0	14.0	7.5		8.0	8.5	10.0	7.5
20 x 4 (45.5)	Straight 22½° 45°	77	4.0	7.0	7.0	7.5	115	8.0	7.5	8.0	8.0	154	11.5	8.0	8.0	8.5	231	20.0	8.5	9.0	9.5
			3.0	6.5	6.5	7.0		6.0	7.0	7.0	7.5		8.0	8.0	15.0	7.5		8.0	8.5	10.0	6.5
24 x 4 (55.0)	Straight 22½° 45°	93	4.1	7.0	7.0	7.5	139	8.0	7.5	8.0	8.0	185	11.5	8.0	8.0	8.5	278	20.0	8.5	9.0	10.0
			3.1	6.5	7.0	7.0		6.0	7.0	7.0	7.5		8.0	8.0	15.0	7.5		8.0	8.5	10.0	10.6
30 x 4 (68.3)	Straight 22½° 45°	116	4.2	7.0	7.0	7.5	175	8.0	7.5	8.0	8.0	233	12.0	8.0	8.0	8.5	349	21.0	8.5	9.5	10.0
			3.1	6.5	7.0	7.0		6.0	7.0	7.5	7.5		8.0	8.0	16.0	7.5		8.0	8.5	10.0	11.0
36 x 4 (83.5)	Straight 22½° 45°	140	4.4	7.0	7.5	7.5	210	8.0	7.5	8.0	8.0	279	12.0	8.0	8.5	9.0	420	21.0	9.0	9.5	10.0
			3.3	6.5	7.0	7.0		6.0	7.0	7.5	7.5		8.0	8.0	16.0	7.5		8.0	8.5	10.0	11.0
8 x 6 (26.5)	Straight 22½° 45°	52	5.0	7.5	7.5	8.0	77	9.5	8.0	8.0	8.5	103	13.0	8.5	9.0	9.0	155	24.0	8.5	10.0	10.5
			3.8	7.0	7.0	7.5		7.0	7.0	7.5	8.0		8.5	10.0	7.5	8.0		8.5	10.0	12.0	7.0
10 x 6 (34.0)	Straight 22½° 45°	66	5.5	7.5	8.0	8.0	98	10.0	8.0	8.5	9.0	131	15.0	9.0	9.5	10.0	196	27.0	10.0	10.5	11.5
			4.1	7.0	7.5	7.5		7.5	7.5	8.0	8.5		9.0	9.0	14.0	7.5		8.0	8.5	10.0	14.0
12 x 6 (41.6)	Straight 22½° 45°	80	6.0	7.5	8.0	8.5	119	11.0	8.0	9.0	9.5	159	15.0	9.0	9.5	10.0	238	28.0	10.0	11.0	11.5
			4.5	7.0	7.5	7.5		8.1	7.5	8.0	8.5		9.0	9.0	14.0	7.5		8.0	8.5	10.0	14.0
16 x 6 (56.6)	Straight 22½° 45°	107	6.2	8.0	8.0	8.5	161	12.0	8.5	9.0	9.5	214	16.0	9.5	10.0	10.5	321	30.0	11.0	11.5	12.5
			4.7	7.0	7.5	7.5		9.0	8.0	8.0	8.5		9.0	9.0	15.0	7.5		8.0	8.5	10.0	15.0
20 x 6 (71.5)	Straight 22½° 45°	135	6.6	8.0	8.5	9.0	202	12.0	9.0	9.5	10.0	269	17.0	9.5	10.0	11.0	403	32.0	11.5	12.0	13.0
			5.0	7.5	7.5	8.0		9.0	8.0	8.5	9.0		9.0	13.0	8.5	9.0		9.5	10.0	16.0	8.0
24 x 6 (86.5)	Straight 22½° 45°	162	7.0	8.0	8.5	9.0	243	13.0	9.0	9.5	10.0	324	18.0	10.0	10.5	11.0	486	33.0	12.0	12.5	13.0
			5.1	7.5	8.0	8.0		10.0	8.0	8.5	9.0		9.0	13.0	8.5	9.0		10.0	10.0	17.0	8.0
30 x 6 (109.0)	Straight 22½° 45°	203	7.0	8.5	8.5	9.5	304	13.0	9.0	10.0	10.5	406	19.0	10.0	11.0	11.5	609	34.0	12.0	12.5	13.5
			5.4	7.5	8.0	8.0		10.0	8.0	9.0	9.0		9.0	14.0	9.0	9.5		10.0	10.0	17.0	8.0
36 x 6 (131.3)	Straight 22½° 45°	245	7.1	8.5	9.0	9.5	368	13.0	9.5	10.0	10.5	490	19.0	10.0	11.0	12.0	735	35.0	12.0	13.0	14.0
			5.5	7.5	8.0	8.5		10.0	8.5	9.0	9.5		9.5	14.0	9.0	9.5		10.0	10.0	26.0	10.0
K FACTOR																					
Max Cfm/Sq Ft Outlet Wall Area		29.0				19.0				14.0				9.6							
Min Cfm/Sq Ft Outlet Wall Area		8.7				5.7				4.2				2.9							



TABLE 21 – WALL OUTLET RATINGS, FOR COOLING ONLY (Cont.)
For Flat Ceilings

OUTLET VELOCITY		1000 FPM					1500 FPM					2000 FPM				
STATIC PRESSURE STANDARD OUTLET		Str B = .093, 22½° = .11 45° = .14					Str B = .211, 22½° = .24 45° = .32					Str B = .375, 22½° = .42 45° = .565				
STATIC PRESSURE WITH METERING PLATE		Str B = .33, 22½° = .33 45° = .475					Str B = .715, 22½° = .74 45° = 1.15					Str B = 1.36				
Nom. Size of Outlet (and Free Area)	Vane Setting	Air Quantity (cfm)	Blow (ft)	Temp Diff (F)			Air Quantity (cfm)	Blow (ft)	Temp Diff (F)			Air Quantity (cfm)	Blow (ft)	Temp Diff (F)		
				15	20	25			15	20	25			15	20	25
				Min Clg Ht					Min Clg Ht					Min Clg Ht		
8 x 4 (16.9)	Straight 22½° 45°	118	24	9.0	9.5	10.0	177	40	10.0	10.5	11.0	237	58	10.5	11.0	12.0
			18	7.5	8.0	8.5		30	8.5	9.0	9.5		44	8.5	9.0	9.5
10 x 4 (21.7)	Straight 22½° 45°	150	26	9.0	9.5	10.0	224	42	10.0	10.5	11.5	299	60	10.5	11.5	12.0
			19	7.5	8.0	8.5		32	8.5	9.0	9.5		45	9.0	9.5	10.0
12 x 4 (24.6)	Straight 22½° 45°	181	27	9.0	9.5	10.0	272	44	10.0	11.0	11.5	362	62	10.5	11.5	12.5
			20	8.0	8.5	9.0		33	8.5	9.0	9.5		47	9.0	9.5	10.0
16 x 4 (35.9)	Straight 22½° 45°	244	28	9.0	10.0	10.5	366	46	10.0	11.0	12.0	488	65	11.0	12.0	12.5
			21	8.0	8.5	9.5		35	9.0	9.0	10.0		49	9.0	10.0	10.5
20 x 4 (45.5)	Straight 22½° 45°	308	29	9.5	10.0	10.5	462	48	10.5	11.0	12.0	616	67	11.0	12.0	13.0
			22	8.0	8.5	9.5		36	9.0	9.5	10.0		50	9.5	10.0	10.5
24 x 4 (55.0)	Straight 22½° 45°	370	30	9.5	10.0	10.5	556	49	10.5	11.5	12.0	740	68	11.5	12.0	13.0
			22	8.5	9.0	9.5		37	9.0	9.5	10.0		51	9.5	10.0	10.5
30 x 4 (68.3)	Straight 22½° 45°	466	30	9.5	10.0	10.5	698	50	10.5	11.5	12.5	932	70	11.5	12.5	13.5
			22	8.5	9.0	9.5		37	9.0	9.5	10.0		53	9.5	10.0	11.0
36 x 4 (83.5)	Straight 22½° 45°	558	31	9.5	10.0	11.0	840	51	11.0	11.5	12.5	1116	71	11.5	12.5	13.5
			23	8.5	9.0	9.5		38	9.0	9.5	10.0		53	9.5	10.5	11.0
8 x 6 (26.5)	Straight 22½° 45°	206	36	9.5	11.0	12.0	310	59	12.0	12.5	13.5	412	82	12.5	14.0	15.0
			27	9.0	9.5	10.0		44	10.0	10.0	11.0		62	10.5	11.5	12.0
10 x 6 (34.0)	Straight 22½° 45°	262	40	11.0	12.0	13.0	392	66	12.5	14.0	15.0	524	92	14.0	15.5	16.5
			30	9.5	10.0	11.0		50	10.5	10.5	12.0		69	11.5	12.5	13.0
12 x 6 (41.6)	Straight 22½° 45°	318	41	11.5	12.5	13.5	476	67	13.0	14.0	15.5	636	94	14.5	15.5	17.0
			31	10.0	10.5	11.0		50	11.0	11.5	12.5		70	11.5	12.5	13.5
16 x 6 (56.6)	Straight 22½° 45°	428	44	12.0	13.0	14.0	642	72	13.5	15.0	16.5	856	102	15.5	17.0	18.0
			33	10.0	11.0	11.5		54	11.5	12.0	13.0		77	12.5	13.5	14.5
20 x 6 (71.5)	Straight 22½° 45°	538	47	12.5	13.5	14.5	806	77	14.5	16.0	17.0	1076	108	16.0	17.5	19.0
			35	10.5	11.5	12.0		58	12.0	12.5	14.0		81	13.0	14.0	15.0
24 x 6 (86.5)	Straight 22½° 45°	648	48	13.0	14.0	15.5	972	79	15.0	16.5	17.5	1296	111	17.0	18.5	19.5
			36	10.5	11.5	12.5		59	12.0	13.0	14.5		83	13.5	14.5	15.5
30 x 6 (109.0)	Straight 22½° 45°	812	50	13.0	14.5	15.5	1218	82	15.5	17.0	18.0	1624	115	17.5	19.0	20.5
			38	11.0	12.0	12.5		62	12.5	13.0	15.0		86	13.5	15.0	16.0
36 x 6 (131.3)	Straight 22½° 45°	980	51	13.5	15.0	16.0	1470	84	16.0	17.5	19.0	1960	119	18.0	19.5	21.0
			38	11.0	12.0	13.0		63	13.0	13.5	15.0		89	14.0	15.0	16.5
			26	9.0	9.5	10.0		42	10.0	10.5	11.0		60	10.5	11.0	12.0

K FACTOR			
Max Cfm/Sq Ft Outlet Wall Area	7.2	4.8	3.6
Min Cfm/Sq Ft Outlet Wall Area	2.2	1.4	1.1

NOTES:

- When employing ratings for flat ceilings, it is understood that the front louvers are set to deflect the air upward toward the ceiling.
- Blow indicates distance from outlet to the point where the air stream is substantially dissipated.
- Underblow. It is not always necessary to blow the entire length of the room unless there are heat load sources at that end, equipment load, open doors, sun-glass, etc. Considering the concentration of room heat load on the basis of Btu/(hr) (sq ft), the outlet blow should cover 75% of the heat load.
- Divergent Blow has vertical louves straight forward in the center, with uniformly increasing angular deflection a maximum at each end. The 45° divergence signifies on angular deflection at each end of the outlet of 45°, and similarly for 22½° divergence.
- Velocity is based on effective face area.
- Static Pressure is that pressure required to produce the indicated velocities and is measured in inches of water.
- Measure ceiling height in the CLEAR only. This is the distance from the floor to the lowest ceiling beam or obstruction.
- The Minimum Ceiling Height (table) is the minimum ceiling height which will give proper operation of the outlet for the given outlet velocity, vane setting, temperature difference, blow, and cfm. The actual measured ceiling height must be equal to or greater than the minimum ceiling height for the selection made. Preferably the top of an outlet should be not less than twice the outlet's height below the minimum ceiling height.
- Cfm / Sq Ft Outlet Wall Area is the standard for judging total room air movement. The maximum value shown results in an air movement in the zone of occupancy of about 50 fpm. It is assumed that furniture, people, etc., obstruct 10% of the room cross-section. If the obstructions vary widely from 10%, the values of the cfm / sq ft outlet wall area should be tempered accordingly.
- For applications requiring a limiting sound level – the outlet velocity is limited by the sound generated by the outlet.



TABLE 21 – WALL OUTLET RATINGS, FOR COOLING ONLY (Cont.)

For Flat Ceilings

OUTLET VELOCITY		250 FPM				375 FPM				500 FPM				750 FPM							
STATIC PRESSURE STANDARD OUTLET		Str B = .01, 22½° = .01 45° = .01				Str B = .013, 22½° = .015 45° = .019				Str B = .024, 22½° = .028 45° = .035				Str B = .051, 22½° = .061 45° = .08							
STATIC PRESSURE WITH METERING PLATE		Str B = .01, 22½° = .015 45° = .028				Str B = .024, 22½° = .043 45° = .065				Str B = .061, 22½° = .082 45° = .118				Str B = .175, 22½° = .19 45° = .27							
Nom. Size of Outlet (and Free Area)	Vane Setting	Air Quantity (cfm)	Temp Diff (F)				Air Quantity (cfm)	Temp Diff (F)				Air Quantity (cfm)	Temp Diff (F)				Air Quantity (cfm)	Temp Diff (F)			
			Blow (ft)	15	20	25		Blow (ft)	15	20	25		Blow (ft)	15	20	25		Blow (ft)	15	20	25
				Min Clg Ht					Min Clg Ht					Min Clg Ht					Min Clg Ht		
12 x 8 (56.7)	Straight 22½° 45°	113	7.4	8.5	9.0	9.5	170	14.0	9.5	10.0	10.5	226	20.0	10.0	11.0	12.0	339	36	12.0	13.5	14.0
			5.5	7.5	8.0	8.5		10.0	8.5	9.0	9.5		15.0	9.0	10.0	10.0		27	10.0	11.0	12.0
16 x 8 (77.1)	Straight 22½° 45°	155	8.0	9.0	9.5	10.0	231	15.0	10.0	10.5	11.0	308	22.0	11.0	12.0	12.5	463	40	13.5	14.5	15.5
			6.0	8.0	8.5	9.0		11.0	9.0	9.5	10.0		16.0	9.5	10.5	11.0		30	11.0	12.0	12.5
20 x 8 (97.6)	Straight 22½° 45°	192	8.5	9.5	10.0	10.5	287	16.0	10.5	11.0	12.0	385	24.0	11.5	12.5	13.5	575	43	14.0	15.5	16.5
			6.5	8.5	9.0	9.5		12.0	9.0	10.0	10.5		18.0	10.0	10.5	11.5		32	11.5	12.5	13.5
24 x 8 (118.0)	Straight 22½° 45°	231	9.0	9.5	10.0	10.5	346	17.0	10.5	11.5	12.5	460	25.0	12.0	13.0	14.0	692	45	14.5	16.0	17.0
			6.9	8.5	9.0	9.5		13.0	9.5	10.0	10.5		19.0	10.5	11.0	12.0		34	12.0	13.0	14.0
30 x 8 (149.0)	Straight 22½° 45°	289	9.5	10.0	10.5	11.0	435	18.0	11.0	12.0	13.0	580	26.0	12.5	13.5	15.0	868	46	15.5	17.0	18.0
			7.0	9.0	9.5	10.0		13.0	9.5	10.0	10.5		19.0	10.5	11.5	12.5		35	12.5	13.5	15.0
36 x 8 (179.0)	Straight 22½° 45°	350	9.9	10.0	11.0	11.5	525	18.0	11.5	12.0	13.0	702	27.0	13.0	14.0	15.5	1048	48	16.0	18.0	19.0
			7.5	9.0	9.5	10.0		13.0	9.5	10.5	11.0		20.0	11.0	12.0	12.5		36	13.0	14.0	15.0
16 x 10 (97.7)	Straight 22½° 45°	198	9.6	9.5	10.0	11.5	297	18.0	11.5	12.5	13.0	396	27.0	13.0	14.0	15.5	595	48	15.5	18.0	19.0
			7.1	9.0	9.5	10.0		13.0	10.0	10.5	11.0		20.0	11.0	12.0	12.5		36	13.0	14.5	15.0
20 x 10 (124.0)	Straight 22½° 45°	249	10.5	10.5	11.0	12.0	374	19.0	12.0	13.0	14.0	497	29.0	13.5	15.0	16.0	746	51	17.0	18.5	20.0
			8.0	9.5	10.0	10.5		14.0	10.5	11.0	12.0		22.0	12.0	12.5	13.5		38	13.5	15.0	16.5
24 x 10 (150.0)	Straight 22½° 45°	300	11.0	11.0	12.0	12.5	450	21.0	12.5	13.5	15.0	600	30.0	14.5	16.0	17.0	899	55	18.5	20.0	21.0
			8.4	10.0	10.5	11.0		16.0	11.0	11.5	12.5		22.0	12.0	13.0	14.0		41	14.5	15.5	17.0
30 x 10 (195.0)	Straight 22½° 45°	364	12.0	12.0	12.5	13.5	564	22.0	13.5	14.5	16.0	751	32.0	15.0	17.0	18.5	1126	58	19.5	21.5	23.0
			9.0	10.5	11.0	12.0		11.0	9.5	10.0	10.5		16.5	10.0	10.5	11.5		29	11.5	12.5	13.5
36 x 10 (227.0)	Straight 22½° 45°	453	12.4	12.0	13.0	14.0	680	22.0	14.0	15.0	16.0	904	33.0	15.0	17.5	19.0	1355	60	20.0	22.0	23.5
			9.1	10.5	11.5	12.0		16.0	12.0	12.5	13.5		25.0	13.0	14.0	15.5		45	14.0	17.5	19.0
16 x 12 (118.0)	Straight 22½° 45°	244	11.0	11.0	12.0	12.5	367	21.0	12.5	13.5	15.0	488	31.0	14.5	16.0	17.0	733	55	18.5	20.0	21.0
			8.1	10.0	10.5	11.0		16.0	11.0	11.5	12.5		23.0	12.0	13.0	14.0		41	14.5	16.0	17.0
20 x 12 (150.0)	Straight 22½° 45°	307	12.1	12.0	13.0	14.0	460	22.0	14.0	15.0	16.0	613	33.0	16.0	17.5	19.0	918	60	20.0	22.0	23.5
			9.1	10.5	11.0	12.0		16.0	12.0	12.5	13.5		25.0	13.0	14.0	15.5		45	16.0	17.5	19.0
24 x 12 (181.0)	Straight 22½° 45°	370	13.0	12.5	13.5	14.7	555	24.0	14.5	16.0	18.0	740	35.0	17.0	18.5	20.0	1110	64	21.5	24.0	25.0
			10.0	11.0	12.0	12.5		18.0	12.0	13.0	14.0		26.0	14.0	15.0	16.0		48	17.0	18.5	20.0
30 x 12 (228.0)	Straight 22½° 45°	462	13.9	13.5	14.5	15.5	695	25.0	15.5	17.0	18.0	925	37.0	18.0	20.0	21.5	1388	68	23.0	26.0	27.5
			10.0	11.5	12.5	13.0		19.0	13.0	14.0	15.0		28.0	14.5	16.0	17.0		51	18.0	20.0	21.5
36 x 12 (275.0)	Straight 22½° 45°	560	14.5	14.0	15.5	16.5	836	27.0	16.0	18.0	19.0	1115	39.0	19.5	21.0	22.5	1673	71	24.5	27.5	29.0
			11.0	12.0	13.0	14.0		20.0	13.5	14.5	15.5		29.0	15.5	16.5	18.0		53	19.0	21.0	22.5

K FACTOR				
Max Cfm/Sq Ft Outlet Wall Area	29.0	19.0	14.0	9.6
Min Cfm/Sq Ft Outlet Wall Area	8.7	5.7	4.2	2.9



TABLE 21 – WALL OUTLET RATINGS, FOR COOLING ONLY (Cont.)

For Flat Ceilings

OUTLET VELOCITY		1000 FPM					1500 FPM					2000 FPM				
STATIC PRESSURE STANDARD OUTLET		Str B = .093, 22½° = .11 45° = .14					Str B = .211, 22½° = .24 45° = .32					Str B = .375, 22½° = .42 45° = .565				
STATIC PRESSURE WITH METERING PLATE		Str B = .33, 22½° = .33 45° = .475					Str B = .715, 22½° = .74 45° = 1.15					Str B = 1.36				
Nom. Size of Outlet (and Free Area)	Vane Setting	Air Quantity (cfm)	Blow (ft)	Temp Diff (F)			Air Quantity (cfm)	Blow (ft)	Temp Diff (F)			Air Quantity (cfm)	Blow (ft)	Temp Diff (F)		
				15	20	25			15	20	25			15	20	25
				Min Clg Ht					Min Clg Ht					Min Clg Ht		
12 x 8 (56.7)	Straight 22½° 45°	452	52	14.0	15.0	16.5	678	86	16.0	18.0	19.0	904	121	18.0	20.0	21.5
			39	11.5	12.5	13.5		65	13.0	14.0	15.5		91	14.0	15.5	17.0
			26	9.0	10.0	10.0		43	10.0	10.5	11.5		62	10.5	11.5	12.0
16 x 8 (77.1)	Straight 22½° 45°	616	57	15.0	16.5	18.0	926	95	18.0	19.5	21.0	1232	134	20.0	22.0	24.0
			43	12.5	13.5	14.5		71	14.0	14.0	17.0		100	15.5	17.0	18.5
			29	9.5	10.0	11.0		48	10.5	11.5	12.0		67	11.0	12.0	13.0
20 x 8 (97.6)	Straight 22½° 45°	770	62	16.0	18.0	19.5	1150	102	19.0	21.0	23.0	1540	144	21.0	23.5	26.0
			47	13.0	14.5	15.5		77	15.0	15.5	18.0		108	16.5	18.0	20.0
			31	10.0	10.5	11.5		51	11.0	12.0	13.0		72	12.0	13.0	14.0
24 x 8 (118.0)	Straight 22½° 45°	920	65	17.0	19.0	20.0	1384	107	20.0	22.5	24.5	1840	151	22.0	25.0	27.5
			49	13.5	15.0	16.0		80	15.5	16.5	18.5		113	17.5	19.0	20.5
			33	10.5	11.0	12.0		54	11.5	12.5	13.0		76	12.0	13.5	14.5
30 x 8 (149.0)	Straight 22½° 45°	1160	68	17.5	19.5	21.0	1736	111	21.0	23.5	25.5	2320	157	23.5	26.0	29.5
			51	14.0	15.5	17.0		83	16.5	17.5	19.5		118	18.0	20.0	21.5
			34	10.5	11.5	12.5		56	11.5	13.0	13.5		79	13.0	14.0	15.0
36 x 8 (179.0)	Straight 22½° 45°	1404	71	18.5	20.5	22.0	2096	116	21.5	25.0	26.5	2808	164	24.5	27.5	31.0
			53	14.5	16.0	17.5		87	17.0	18.0	20.0		123	19.0	21.0	22.5
			36	11.0	12.0	12.5		58	12.0	13.0	14.0		82	13.0	14.5	15.5
16 x 10 (97.7)	Straight 22½° 45°	792	71	18.0	20.5	22.0	1190	116	21.0	25.0	26.5	1584	164	24.0	27.5	31.0
			53	14.5	16.0	17.5		87	17.0	19.0	20.0		123	19.0	21.0	22.5
			36	11.0	12.0	12.5		58	12.0	13.0	14.0		82	13.0	14.5	15.5
20 x 10 (124.0)	Straight 22½° 45°	994	75	19.5	22.0	24.0	1492	122	23.0	26.5	29.0	1988	174	26.0	29.5	34.0
			56	15.5	17.0	18.5		92	18.0	19.0	21.5		130	20.0	22.5	24.0
			38	11.5	12.5	13.5		61	13.0	14.0	15.0		87	14.0	15.5	16.5
24 x 10 (150.0)	Straight 22½° 45°	1200	80	21.0	24.0	25.5	1798	131	24.5	28.5	31.0	2400	185	28.0	32.0	36.5
			60	16.5	18.5	19.5		98	19.0	20.0	22.5		139	21.5	24.0	25.5
			40	12.0	13.0	14.0		66	13.5	14.5	15.5		93	14.5	16.5	17.0
30 x 10 (195.0)	Straight 22½° 45°	1502	86	22.5	25.5	27.5	2252	139	26.5	30.5	34.0	3004	196	30.5	34.0	39.5
			65	18.0	19.5	21.0		104	20.5	21.5	24.5		147	23.0	26.0	28.0
			43	12.5	14.0	15.0		70	14.0	15.5	16.5		98	15.5	17.0	18.5
36 x 10 (227.0)	Straight 22½° 45°	1808	87	23.5	26.5	28.5	2710	142	27.0	31.5	35.0	3616	200	31.5	36.0	40.5
			65	18.5	20.0	21.5		106	21.0	23.0	25.0		150	23.5	27.0	29.0
			44	13.0	14.5	15.0		71	14.5	16.0	17.0		100	15.5	17.5	19.0
16 x 12 (118.0)	Straight 22½° 45°	976	81	21.0	24.0	25.5	1466	131	24.5	28.0	31.0	1952	158	28.0	32.0	36.5
			61	16.5	18.5	19.5		98	19.0	21.5	22.5		138	21.5	24.0	25.5
			41	12.0	13.0	14.0		66	13.5	14.5	15.5		93	14.5	16.5	17.0
20 x 12 (150.0)	Straight 22½° 45°	1226	87	23.5	26.5	28.5	1836	142	27.0	31.5	35.0	2452	200	31.5	36.0	40.5
			65	18.5	20.0	21.5		106	21.0	23.5	25.0		150	23.5	27.0	29.0
			44	13.0	14.5	15.0		71	14.5	16.0	17.0		100	15.5	17.5	19.0
24 x 12 (181.0)	Straight 22½° 45°	1480	93	25.0	28.5	31.0	2220	153	29.0	34.0	37.5	2960	213	34.5	38.5	42.5
			70	19.5	21.5	23.0		115	22.0	25.0	26.5		160	25.0	29.0	31.0
			47	13.5	15.0	16.0		77	15.0	17.0	18.0		107	16.5	18.5	20.0
30 x 12 (228.0)	Straight 22½° 45°	1850	98	27.0	31.0	34.0	2776	163	31.5	36.5	40.5	3700	226	38.0	43.0	47.0
			74	21.0	23.0	25.0		122	24.0	27.0	28.5		169	27.0	31.0	33.5
			49	14.5	16.0	17.0		82	16.0	18.0	19.0		113	17.5	19.5	21.0
36 x 12 (275.0)	Straight 22½° 45°	2230	103	29.0	33.0	36.0	3346	172	33.5	38.0	42.5	4460	238	40.0	45.0	50.0
			77	22.0	24.5	26.5		129	25.0	28.0	30.0		178	28.5	32.5	35.5
			52	15.0	16.0	17.5		86	16.5	18.5	20.0		119	18.0	20.5	22.0

K FACTOR			
Max Cfm/Sq Ft Outlet Wall Area	7.2	4.8	3.6
Min Cfm/Sq Ft Outlet Wall Area	2.2	1.4	1.1

NOTES:

- When employing ratings for flat ceilings, it is understood that the front louvers are set to deflect the air upward toward the ceiling.
- Blow indicates distance from outlet to the point where the air stream is substantially dissipated.
- Underblow. It is not always necessary to blow the entire length of the room unless there are heat load sources at that end, equipment load, open doors, sun-glass, etc. Considering the concentration of room heat load on the basis of Btu/(hr) (sq ft), the outlet blow should cover 75% of the heat load.
- Divergent Blow has vertical louvers straight forward in the center, with uniformly increasing angular deflection to a maximum at each end. The 45° divergence signifies on angular deflection at each end of the outlet of 45°, and similarly for 22½° divergence.
- Velocity is based on effective face area.
- Static Pressure is that pressure required to produce the indicated velocities and is measured in inches of water.
- Measure ceiling height in the CLEAR only. This is the distance from the floor to the lowest ceiling beam or obstruction.
- The Minimum Ceiling Height (table) is the minimum ceiling height which will give proper operation of the outlet for the given outlet velocity, vane setting, temperature difference, blow, and cfm. The actual measured ceiling height must be equal to or greater than the minimum ceiling height for the selection made. Preferably the top of an outlet should be not less than twice the outlet's height below the minimum ceiling height.
- Cfm / Sq ft Outlet Wall Area is the standard for judging total room air movement. The maximum value shown results in an air movement in the zone of occupancy of about 50 fpm. It is assumed that furniture, people, etc., obstruct 10% of the room cross-section. If the obstructions vary widely from 10%, the values of the cfm / sq ft outlet wall area should be tempered accordingly.
- For applications requiring a limiting sound level – the outlet velocity is limited by the sound generated by the outlet.



TABLE 21 – WALL OUTLET RATINGS, FOR COOLING ONLY (Cont.)
For Beamed Ceilings

OUTLET VELOCITY		250 FPM				375 FPM				500 FPM				750 FPM							
STATIC PRESSURE STANDARD OUTLET		Str B = .01, 22½° = .01 45° = .01				Str B = .013, 22½° = .015 45° = .019				Str B = .024, 22½° = .028 45° = .035				Str B = .051, 22½° = .061 45° = .08							
STATIC PRESSURE WITH METERING PLATE		Str B = .01, 22½° = .015 45° = .028				Str B = .024, 22½° = .043 45° = .065				Str B = .061, 22½° = .082 45° = .118				Str B = .175, 22½° = .19 45° = .27							
Nom. Size of Outlet (and Free Area)	Vane Setting	Air Quantity (cfm)	Blow (ft)	Temp Diff (F)				Air Quantity (cfm)	Blow (ft)	Temp Diff (F)				Air Quantity (cfm)	Blow (ft)	Temp Diff (F)					
				15	20	25				15	20	25				15	20	25			
				Min Clg Ht						Min Clg Ht						Min Clg Ht					
8 x 4 (16.9)	Straight 22½° 45°	30	3.5 2.5 1.8	7.3 6.9 6.5	7.7 7.2 6.8	8.1 7.5 7.0	44	7.0 5.1 3.5	8.2 7.5 6.5	8.7 7.9 6.5	9.1 8.2 7.5	59	10.0 7.5 5.0	8.7 8.0 7.2	9.3 8.4 7.5	9.8 8.8 7.8	89	17.0 13.0 9.0	9.7 8.5 7.4	10.4 9.1 7.8	11.1 9.6 8.1
10 x 4 (21.7)	Straight 22½° 45°	37	3.5 2.5 1.8	7.4 7.0 6.5	7.7 7.3 6.8	8.2 7.6 7.0	57	7.4 5.5 3.7	8.2 7.5 6.9	8.8 8.0 7.2	9.2 8.2 7.5	75	10.5 8.0 5.4	8.8 8.0 7.2	9.4 8.5 7.6	9.9 8.8 7.8	112	18.0 13.0 9.0	9.8 8.6 7.4	10.5 9.2 7.9	11.2 9.6 8.2
12 x 4 (24.6)	Straight 22½° 45°	44	3.5 2.5 1.8	7.4 7.1 6.5	7.8 7.3 6.9	8.2 7.6 7.0	68	7.5 5.5 3.9	8.3 7.6 7.0	8.8 8.0 7.2	9.2 8.3 7.5	91	11.0 8.1 5.5	8.9 8.1 7.2	9.4 8.5 7.6	9.9 8.9 7.9	136	18.0 13.0 9.0	9.9 8.6 7.5	10.6 9.2 7.9	11.3 9.8 8.2
16 x 4 (35.9)	Straight 22½° 45°	61	3.7 2.7 2.0	7.5 7.2 6.5	7.9 7.4 7.0	8.3 7.7 7.0	92	7.9 6.0 4.0	8.4 7.7 7.0	8.9 8.1 7.3	9.4 8.4 7.6	122	11.0 8.1 5.5	9.0 8.2 7.3	9.6 8.6 7.7	10.0 9.0 7.9	183	19.0 14.0 10.0	10.0 8.8 7.6	10.8 9.4 8.0	11.5 9.9 8.3
20 x 4 (45.5)	Straight 22½° 45°	77	4.0 3.0 2.0	7.6 7.2 6.6	8.0 7.5 7.0	8.4 7.8 7.1	115	8.0 6.0 4.0	8.4 7.8 7.0	9.0 8.2 7.4	9.4 8.5 7.6	154	11.5 8.5 6.0	9.1 8.3 7.4	9.6 8.7 7.8	10.1 9.1 8.0	231	20.0 15.0 10.0	10.2 8.9 7.6	11.0 9.5 8.1	11.7 10.0 8.4
24 x 4 (55.0)	Straight 22½° 45°	93	4.1 3.1 2.0	7.6 7.2 6.6	8.0 7.5 7.0	8.4 7.8 7.1	139	8.0 6.0 4.0	8.5 7.8 7.1	9.0 8.2 7.4	9.5 8.6 7.6	185	11.5 8.5 6.0	9.2 8.3 7.4	9.6 8.8 7.8	10.2 9.1 8.0	278	20.0 15.0 10.0	10.2 8.8 7.6	11.0 9.5 8.1	11.8 10.1 8.4
30 x 4 (68.3)	Straight 22½° 45°	116	4.2 3.1 2.1	7.7 7.3 6.6	8.1 7.6 7.0	8.5 7.9 7.2	175	8.0 6.0 4.0	8.5 7.9 7.1	9.0 8.3 7.5	9.6 8.6 7.7	233	12.0 9.0 4.6	9.3 8.4 7.4	9.7 8.8 7.8	10.3 9.2 8.0	349	21.0 16.0 11.0	10.3 9.0 7.7	11.1 9.6 8.2	11.9 10.2 8.5
36 x 4 (83.5)	Straight 22½° 45°	140	4.4 3.3 2.2	7.7 7.3 6.6	8.2 7.6 7.0	8.5 7.9 7.2	210	8.0 6.0 4.0	8.5 7.9 7.1	9.1 8.3 7.5	9.6 8.6 7.7	279	12.0 9.0 6.0	9.3 8.4 7.4	9.8 8.9 7.9	10.4 9.2 8.1	420	21.0 16.0 11.0	10.4 9.0 7.8	11.2 9.5 8.2	12.0 10.3 8.6
8 x 6 (26.5)	Straight 22½° 45°	52	5.0 3.8 2.5	8.2 7.6 6.8	8.6 8.0 7.3	9.0 8.3 7.4	77	9.5 7.0 4.8	9.0 8.3 7.3	9.6 8.8 7.8	10.2 9.2 8.0	103	13.0 10.0 6.0	9.9 8.8 7.7	10.4 9.4 8.2	11.1 9.8 8.5	155	24.0 18.0 12.0	10.3 8.9 8.2	12.2 10.4 8.6	13.1 11.2 9.2
10 x 6 (34.0)	Straight 22½° 45°	66	5.5 4.1 2.8	8.6 7.9 7.1	9.2 8.4 7.6	9.6 8.7 7.8	98	10.0 7.5 5.0	9.6 8.7 7.6	10.2 9.3 8.0	10.9 9.8 8.4	131	15.0 11.0 7.0	10.5 9.3 8.1	11.2 9.9 8.6	11.9 10.5 8.9	196	27.0 20.0 14.0	12.3 10.4 8.6	13.3 11.2 9.1	14.2 12.1 9.7
12 x 6 (41.6)	Straight 22½° 45°	80	6.0 4.5 3.0	8.7 8.0 7.2	9.2 8.4 7.6	9.7 8.8 7.8	119	11.0 8.1 5.5	9.7 8.8 7.7	10.4 9.4 8.1	11.1 9.8 8.5	159	15.0 11.0 7.0	10.6 9.4 8.1	11.4 10.1 8.6	12.2 10.7 9.0	238	28.0 21.0 14.0	12.5 10.6 8.7	13.6 11.4 9.2	14.5 12.2 9.8
16 x 6 (56.6)	Straight 22½° 45°	107	6.2 4.7 3.2	9.1 8.2 7.4	9.6 8.7 7.8	10.2 9.0 8.1	161	12.0 9.0 6.0	10.1 9.1 7.9	10.8 9.7 8.4	11.6 10.2 8.8	214	16.0 12.0 8.0	11.2 9.8 8.4	12.0 10.5 9.0	12.8 11.2 9.3	321	30.0 22.0 15.0	13.3 11.2 9.0	14.5 12.0 9.7	15.5 12.9 10.3
20 x 6 (71.5)	Straight 22½° 45°	135	6.6 5.0 3.2	9.4 8.4 7.6	9.9 9.0 8.0	10.5 9.3 8.3	202	12.0 9.0 6.6	10.5 9.3 8.1	11.2 10.0 8.6	12.1 10.5 9.0	269	17.0 13.0 9.0	11.6 10.1 8.6	12.5 10.9 9.2	13.4 11.6 9.6	403	32.0 24.0 16.0	14.0 11.6 9.3	15.2 12.5 10.0	16.3 13.5 10.6
24 x 6 (86.5)	Straight 22½° 45°	162	7.0 5.1 3.5	9.6 8.8 7.7	10.1 9.1 8.1	10.7 9.5 8.5	243	13.0 10.0 6.5	10.7 9.5 8.2	11.5 10.2 8.8	12.3 10.7 9.2	324	18.0 13.0 9.0	11.9 10.3 8.7	12.8 11.1 9.4	13.7 11.9 9.8	486	33.0 25.0 17.0	14.4 11.9 9.5	15.7 12.9 10.2	16.9 13.9 10.8
30 x 6 (109.0)	Straight 22½° 45°	203	7.0 5.4 3.5	9.6 8.7 7.8	10.1 9.3 8.2	11.0 9.7 8.6	304	13.0 10.0 6.5	11.0 9.6 8.4	11.8 10.4 8.9	12.6 10.9 9.4	406	19.0 14.0 10.0	12.2 10.6 8.9	13.3 11.4 9.6	14.1 12.2 10.0	609	34.0 25.0 17.0	14.8 12.1 9.7	16.1 13.3 10.4	17.4 14.2 11.1
36 x 6 (131.3)	Straight 22½° 45°	245	7.1 5.5 3.5	9.9 8.8 7.9	10.5 9.6 8.4	11.1 9.8 8.7	368	13.0 10.0 6.5	11.2 9.8 8.5	12.0 10.6 9.1	12.4 11.1 9.5	490	19.0 14.0 10.0	12.5 10.7 9.0	13.6 11.6 9.7	14.7 12.5 10.1	735	35.0 26.0 18.0	15.2 12.4 9.9	16.6 13.5 10.6	18.0 14.6 11.3
K FACTOR																					
Max Cfm/Sq Ft Outlet Wall Area		29.0				19.0				14.0				9.6							
Min Cfm/Sq Ft Outlet Wall Area		8.7				5.7				4.2				2.9							



TABLE 21 – WALL OUTLET RATINGS, FOR COOLING ONLY (Cont.)
For Beamed Ceilings

OUTLET VELOCITY		1000 FPM					1500 FPM					2000 FPM				
STATIC PRESSURE STANDARD OUTLET		Str B = .093, 22½° = .11 45° = .14					Str B = .211, 22½° = .24 45° = .32					Str B = .375, 22½° = .42 45° = .565				
STATIC PRESSURE WITH METERING PLATE		Str B = .33, 22½° = .33 45° = .475					Str B = .715, 22½° = .74 45° = 1.15					Str B = 1.36				
Nom. Size of Outlet (and Free Area)	Vane Setting	Air Quantity (cfm)	Blow (ft)	Temp Diff (F)			Air Quantity (cfm)	Blow (ft)	Temp Diff (F)			Air Quantity (cfm)	Blow (ft)	Temp Diff (F)		
				15	20	25			15	20	25			15	20	25
				Min Clg Ht					Min Clg Ht					Min Clg Ht		
8 x 4 (16.9)	Straight 22½° 45°	118	24	10.4	11.2	11.9	177	40	11.9	12.9	13.8	237	58	12.7	13.9	15.0
			18	9.0	9.6	10.2		30	9.8	10.5	11.2		44	10.2	11.0	11.7
			12	7.6	8.0	8.4		20	7.7	8.1	8.5		29	7.8	8.2	8.6
10 x 4 (21.7)	Straight 22½° 45°	150	26	10.6	11.4	12.1	224	42	12.1	13.1	14.1	299	60	13.0	14.2	15.4
			19	9.1	9.7	10.4		32	10.0	10.7	11.4		45	10.4	11.3	12.0
			13	7.7	8.2	8.5		21	7.8	8.4	8.7		30	8.0	8.5	8.9
12 x 4 (24.6)	Straight 22½° 45°	181	27	10.7	11.6	12.3	272	44	12.3	13.4	14.4	362	62	13.3	14.5	15.7
			20	9.3	9.9	10.5		33	10.2	10.9	11.6		47	10.6	11.6	12.3
			14	7.8	8.2	8.6		22	8.0	8.5	8.9		31	8.2	8.7	9.2
16 x 4 (35.9)	Straight 22½° 45°	244	28	11.0	11.9	12.7	366	46	12.6	13.8	14.8	488	65	13.7	15.0	16.2
			21	9.5	10.1	10.7		35	10.4	11.3	12.0		49	11.0	12.0	12.8
			14	7.8	8.4	8.6		23	8.2	8.7	9.2		33	8.5	9.0	9.5
20 x 4 (45.5)	Straight 22½° 45°	308	29	11.2	12.1	12.9	462	48	12.9	14.1	15.1	616	67	14.0	15.3	16.6
			22	9.7	10.3	10.9		36	10.6	11.5	12.2		50	11.3	12.3	13.1
			15	7.9	8.5	8.8		24	8.3	8.9	9.4		34	8.6	9.2	9.7
24 x 4 (55.0)	Straight 22½° 45°	370	30	11.3	12.3	13.1	556	49	13.0	14.2	15.3	740	68	14.2	15.5	16.8
			22	9.8	10.4	11.0		37	10.8	11.6	12.4		51	11.4	12.4	13.3
			15	8.0	8.5	8.8		25	8.4	9.0	9.4		34	8.7	9.3	9.9
30 x 4 (68.3)	Straight 22½° 45°	466	30	11.4	12.4	13.3	698	50	13.2	14.4	15.5	932	70	14.4	15.7	17.0
			22	9.9	10.5	11.2		37	10.9	11.8	12.6		53	11.6	12.6	13.5
			15	8.0	8.6	8.9		25	8.5	9.1	9.6		35	8.9	9.5	10.0
36 x 4 (83.5)	Straight 22½° 45°	558	31	11.5	12.5	13.4	840	51	13.3	14.5	15.7	1116	71	14.5	15.9	17.2
			23	10.0	10.6	11.2		38	11.0	11.9	12.6		53	11.7	12.8	13.6
			16	8.1	8.6	9.0		26	8.5	9.2	9.6		34	9.0	9.6	10.1
8 x 6 (26.5)	Straight 22½° 45°	206	36	11.6	13.8	14.9	310	59	14.7	16.2	17.5	412	82	16.2	17.9	19.3
			27	10.8	11.5	12.3		44	12.0	13.1	14.0		62	13.0	14.2	15.3
			18	8.6	9.2	9.6		30	9.3	10.0	10.6		41	9.9	10.6	11.3
10 x 6 (34.0)	Straight 22½° 45°	262	40	13.8	15.2	16.5	392	66	16.1	17.9	19.5	524	92	18.1	20.0	21.7
			30	11.6	12.6	13.5		50	13.2	14.4	15.5		69	14.3	15.7	17.0
			20	9.2	9.9	10.4		33	10.1	10.8	11.6		46	10.8	11.6	12.5
12 x 6 (41.6)	Straight 22½° 45°	318	41	14.1	15.5	16.9	476	67	16.4	18.3	19.9	636	94	18.5	20.4	22.1
			31	11.8	12.8	13.7		50	13.4	14.7	15.7		70	14.6	16.0	17.3
			21	9.3	10.0	10.5		34	10.2	11.0	11.8		47	11.0	11.8	12.7
16 x 6 (56.6)	Straight 22½° 45°	428	44	15.0	16.4	18.1	642	72	17.6	19.7	21.3	856	102	20.0	22.1	23.9
			33	12.5	13.6	14.6		54	14.3	15.6	16.9		77	15.6	17.1	18.7
			22	9.7	10.5	11.1		36	10.8	11.6	12.5		51	11.6	12.5	13.5
20 x 6 (71.5)	Straight 22½° 45°	538	47	15.7	17.5	19.0	806	77	18.6	20.8	22.4	1076	108	21.1	23.3	25.2
			35	13.1	14.2	15.3		58	14.9	16.4	17.8		81	16.4	17.9	19.7
			24	10.1	10.8	11.5		39	11.2	12.1	13.0		54	12.1	13.0	14.1
24 x 6 (86.5)	Straight 22½° 45°	648	48	16.3	18.0	19.7	972	79	19.3	21.6	23.2	1296	111	21.9	24.2	26.1
			36	13.4	14.6	15.7		59	15.4	16.9	18.4		83	17.0	18.5	20.4
			24	10.3	11.1	11.8		40	11.6	12.4	13.3		56	12.4	13.4	14.5
30 x 6 (109.0)	Straight 22½° 45°	812	50	16.9	18.7	20.4	1218	82	20.0	22.4	24.0	1624	115	22.7	25.0	27.1
			38	13.8	15.0	16.2		62	15.9	17.4	19.0		86	17.5	19.1	21.1
			25	10.6	11.4	12.1		41	11.7	12.6	13.7		58	12.7	13.7	14.9
36 x 6 (131.3)	Straight 22½° 45°	980	51	17.3	19.2	21.0	1470	84	20.6	23.0	24.8	1960	119	23.4	25.8	28.0
			38	14.1	15.4	16.7		63	16.3	17.8	19.6		89	18.0	19.6	21.7
			26	10.8	11.6	12.4		42	11.9	12.9	14.0		60	13.0	14.0	15.3

K FACTOR		
Max Cfm/Sq Ft Outlet Wall Area	7.2	3.6
Min Cfm/Sq Ft Outlet Wall Area	2.2	1.1

NOTES:

- Divergent Blow has vertical louvers straight forward in the center, with uniformly increasing angular deflection to a maximum at each end. The 45° divergence signifies an angular deflection at each end of the outlet of 45°, and similarly for 22½° divergence.
- Blow indicates distance from outlet to the point where the air stream is substantially dissipated.
- Underblow. It is not always necessary to blow the entire length of the room unless there are heat load sources at that end, equipment load, open doors, sun-glass, etc. Considering the concentration of room heat load on the basis of Btu / (hr)(sq ft), the outlet blow should cover 75% of the heat load.
- Velocity is based on effective face area.
- Static Pressure is that pressure required to produce the indicated velocities and is measured in inches of water.
- Measure ceiling height in the CLEAR only. This is the distance from the floor to the lowest ceiling beam or obstruction.
- The Minimum Ceiling Height (table) is the minimum ceiling height which will give proper operation of the outlet for the given outlet velocity, vane setting, temperature difference, blow, and cfm. The actual measured ceiling height must be equal to or greater than the selection made. Preferably the top of an outlet should be not less than twice the outlet's height below the minimum ceiling height.
- Cfm / Sq Ft Outlet Wall Area is the standard for judging total room air movement. The maximum value shown results in an air movement in the zone of occupancy of about 50 fpm. It is assumed that furniture, people, etc., obstruct 10% of the room cross-section. If the obstructions vary widely from 10% the values of the cfm / sq ft outlet wall area should be tempered accordingly.
- For applications requiring a limiting sound level – the outlet velocity is limited by the sound generated by the outlet.

TABLE 21 – WALL OUTLET RATINGS, FOR COOLING ONLY (Cont.)

For Beamed Ceilings

OUTLET VELOCITY		250 FPM					375 FPM					500 FPM					750 FPM				
STATIC PRESSURE STANDARD OUTLET		Str B = .01, 22½° = .01 45° = .01					Str B = .013, 22½° = .015 45° = .019					Str B = .024, 22½° = .028 45° = .035					Str B = .051, 22½° = .061 45° = .08				
STATIC PRESSURE WITH METERING PLATE		Str B = .01, 22½° = .015 45° = .028					Str B = .024, 22½° = .043 45° = .065					Str B = .061, 22½° = .082 45° = .118					Str B = .175, 22½° = .19 45° = .27				
Nom. Size of Outlet (and Free Area)	Vane Setting	Air Quantity (cfm)	Blow (ft)			Air Quantity (cfm)	Blow (ft)			Air Quantity (cfm)	Blow (ft)			Air Quantity (cfm)	Blow (ft)						
			Temp Diff (F)				Temp Diff (F)				Temp Diff (F)										
			15	20	25		15	20	25		15	20	25		15	20	25				
			Min Cfg Ht			Min Cfg Ht			Min Cfg Ht			Min Cfg Ht									
12 x 8 (56.7)	Straight 22½° 45°	113	7.4	10.0	10.6	11.3	170	14.0	11.3	12.1	13.0	226	20.0	12.6	13.8	14.7	339	36	15.4	17.0	18.3
			5.5	8.9	9.5	10.0		7.0	9.9	10.7	11.2		15.0	10.9	11.8	12.7		27	12.6	13.7	14.8
			3.7	8.0	8.4	8.8		8.0	8.6	9.2	9.8		11.0	9.1	9.8	10.3		18	10.0	10.8	11.4
16 x 8 (77.1)	Straight 22½° 45°	155	8.0	10.6	11.4	12.1	231	15.0	12.1	13.1	14.0	308	22.0	13.7	15.0	16.1	463	40	16.9	18.6	20.3
			6.0	9.4	10.1	10.7		11.0	10.4	11.4	11.9		16.0	11.7	12.7	13.7		30	13.7	15.0	16.2
			4.0	8.4	8.9	9.3		7.5	9.0	9.7	10.1		11.5	9.6	10.4	10.9		20	10.6	11.5	12.2
20 x 8 (97.6)	Straight 22½° 45°	192	8.5	11.1	12.0	12.7	287	16.0	12.7	13.8	14.9	385	24.0	14.6	15.9	17.2	575	43	18.1	20.0	21.7
			6.5	9.8	10.6	11.3		12.0	10.9	11.9	12.6		18.0	12.4	13.4	14.5		32	14.5	16.0	17.3
			4.3	8.7	9.2	9.7		8.0	9.4	10.0	10.6		12.5	10.0	10.8	11.5		22	11.3	12.1	13.0
24 x 8 (118.0)	Straight 22½° 45°	231	9.0	11.5	12.4	13.2	346	17.0	13.3	14.3	15.6	460	25.0	15.2	16.6	18.1	692	45	19.0	21.0	22.7
			6.9	10.2	10.9	11.7		13.0	11.4	12.3	13.2		19.0	12.8	13.9	15.1		34	15.2	16.8	18.2
			4.5	8.9	9.4	10.0		8.5	9.6	10.2	10.8		13.0	10.4	11.0	11.8		23	11.6	12.5	13.4
30 x 8 (149.0)	Straight 22½° 45°	289	9.5	12.0	12.8	13.8	435	18.0	13.8	14.9	16.3	580	26.0	15.9	17.3	19.0	868	46	20.0	22.0	23.9
			7.0	10.6	11.3	12.1		13.0	11.8	12.7	13.7		19.0	13.4	14.5	15.7		35	16.0	17.5	19.1
			4.7	9.1	9.6	10.2		9.0	9.9	10.5	11.1		13.5	10.7	11.4	12.2		23	12.0	13.0	14.0
36 x 8 (179.0)	Straight 22½° 45°	350	9.9	12.4	13.3	14.2	525	18.0	14.3	15.5	16.8	702	27.0	16.5	18.0	19.7	1048	48	20.8	22.9	24.8
			7.5	10.8	11.7	12.5		13.0	12.1	13.1	14.1		20.0	13.7	15.0	16.2		36	16.4	18.2	19.7
			5.0	9.3	9.8	10.4		9.0	10.1	10.7	11.4		14.0	10.9	11.7	12.6		24	12.4	13.3	14.4
16 x 10 (97.7)	Straight 22½° 45°	198	9.6	12.2	13.3	14.2	297	18.0	14.1	15.5	16.8	396	27.0	16.3	18.0	19.7	595	48	20.5	22.9	24.8
			7.1	10.8	11.7	12.5		13.0	12.1	13.1	14.1		20.0	13.7	15.0	16.2		36	16.4	18.2	19.7
			5.0	9.3	9.8	10.4		9.0	10.1	10.7	11.4		14.5	10.9	11.7	12.6		24	12.4	13.3	14.4
20 x 10 (124.0)	Straight 22½° 45°	249	10.5	13.1	14.1	15.2	374	19.0	15.2	16.5	18.0	497	29.0	17.5	19.3	21.2	746	51	22.4	24.6	26.6
			8.0	11.4	12.3	13.2		14.0	12.9	13.8	15.0		22.0	14.7	15.9	17.3		38	17.7	19.4	21.3
			5.2	9.7	10.2	10.8		9.5	10.5	11.1	11.9		15.0	11.5	12.2	13.3		26	13.1	14.1	15.3
24 x 10 (150.0)	Straight 22½° 45°	300	11.0	13.9	15.0	16.1	450	21.0	16.1	17.6	19.1	600	30.0	18.7	20.6	22.5	899	55	24.1	26.5	28.4
			8.4	12.0	13.0	13.9		16.0	13.6	14.6	15.9		22.0	15.4	16.8	18.3		41	18.8	20.7	22.4
			5.5	10.0	10.4	11.2		10.5	10.8	11.5	12.2		15.5	11.9	12.6	13.8		28	13.7	14.8	16.1
30 x 10 (195.0)	Straight 22½° 45°	364	12.0	14.8	16.0	17.3	564	22.0	17.3	18.9	20.5	751	32.0	20.0	22.1	24.4	1126	58	26.0	28.7	30.9
			9.0	12.7	13.8	14.8		16.0	14.5	15.5	16.9		24.0	16.5	18.0	19.6		44	20.3	22.3	24.4
			6.0	10.4	10.9	11.7		11.0	11.3	12.0	12.8		16.5	12.6	13.3	14.6		29	14.5	15.7	17.1
36 x 10 (227.0)	Straight 22½° 45°	453	12.4	15.2	16.4	17.7	680	22.0	17.7	19.5	21.1	904	33.0	20.5	22.7	25.0	1355	60	26.7	29.5	31.7
			9.1	13.0	14.0	15.1		16.0	14.8	15.8	17.3		25.0	16.9	18.3	20.0		45	20.8	23.0	25.1
			6.1	10.5	11.0	11.8		11.0	11.4	12.1	13.0		17.0	13.7	13.5	14.9		30	14.8	16.1	17.4
16 x 12 (118.0)	Straight 22½° 45°	244	11.0	13.9	15.0	16.1	367	21.0	16.1	17.6	19.1	488	31.0	18.7	20.6	22.5	733	55	24.1	26.5	28.4
			8.1	12.0	13.0	13.9		16.0	13.6	14.6	15.9		23.0	15.4	16.8	18.3		41	18.8	20.7	22.4
			5.5	10.0	10.4	11.2		11.0	10.8	11.5	12.2		16.0	11.9	12.6	13.8		28	13.7	14.8	16.1
20 x 12 (150.0)	Straight 22½° 45°	307	12.1	15.2	16.4	17.7	460	22.0	17.7	19.5	21.1	613	33.0	20.5	22.7	25.0	918	60	26.7	29.5	31.7
			9.1	13.0	14.0	15.1		16.0	14.8	15.8	17.3		25.0	16.9	18.3	20.0		45	20.8	23.0	25.1
			6.0	10.5	11.0	11.8		11.0	11.4	12.1	13.0		17.0	13.7	13.5	14.9		30	14.8	16.1	17.4
24 x 12 (181.0)	Straight 22½° 45°	370	13.0	16.1	17.4	18.8	555	24.0	18.7	20.7	23.4	740	35.0	21.8	24.5	26.7	1110	64	28.7	32.0	34.0
			10.0	13.6	14.8	16.0		18.0	15.6	16.8	18.3		26.0	17.8	19.5	21.2		48	22.1	24.5	26.7
			6.5	10.8	11.4	12.2		12.0	11.8	12.6	13.5		18.0	13.3	14.1	15.5		32	15.5	17.0	18.4
30 x 12 (228.0)	Straight 22½° 45°	462	13.9	17.1	18.7	20.2	695	25.0	20.0	22.2	24.0	925	37.0	23.3	26.4	28.8	1388	68	31.1	35.0	37.2
			10.0	14.4	15.6	16.9		19.0	16.4	17.7	19.4		28.0	19.0	20.7	22.6		51	23.8	26.3	28.8
			7.0	11.2	11.9	12.7		12.0	12.3	13.2	14.1		19.0	13.9	14.8	16.3		34	16.3	18.0	19.3
36 x 12 (275.0)	Straight 22½° 45°	560	14.5	18.0	19.8	21.3	836	27.0	21.0	23.6	25.3	1115	39.0	25.7	27.7	30.3	1673	71	33.0	37.3	39.7
			11.0	15.0	16.3	17.6		20.0	17.1	18.5	20.3		29.0	19.8	21.7	23.7		53	25.0	27.7	30.4
			8.0	11.5	12.2	13.1		13.0	12.7	13.6	14.6		20.0	14.4	15.4	17.0		36	16.9	18.7	20.1
K FACTOR																					
Max Cfm/Sq Ft Outlet Wall Area		29.0					19.0					14.0					9.6				
Min Cfm/Sq Ft Outlet Wall Area		8.7					5.7					4.2					2.9				

TABLE 21 – WALL OUTLET RATINGS, FOR COOLING ONLY (Cont.)
For Beamed Ceilings

OUTLET VELOCITY		1000 FPM					1500 FPM					2000 FPM				
STATIC PRESSURE STANDARD OUTLET		Str B = .093, 22½° = .11 45° = .14					Str B = .211, 22½° = .24 45° = .32					Str B = .375, 22½° = .42 45° = .565				
STATIC PRESSURE WITH METERING PLATE		Str B = .33, 22½° = .33 45° = .475					Str B = .715, 22½° = .74 45° = 1.15					Str B = .375				
Nom. Size of Outlet (and Free Area)	Vane Setting	Air Quantity (cfm)	Blow (ft)	Temp Diff (F)			Air Quantity (cfm)	Blow (ft)	Temp Diff (F)			Air Quantity (cfm)	Blow (ft)	Temp Diff (F)		
				15	20	25			15	20	25			15	20	25
				Min Clg Ht					Min Clg Ht					Min Clg Ht		
12 x 8 (56.7)	Straight 22½° 45°	452	52	17.7	19.5	21.4	678	86	21.0	23.5	25.3	904	121	23.9	26.4	28.6
			39	14.4	15.6	17.0		65	16.6	18.1	20.0		91	18.3	20.0	22.2
			26	10.9	11.8	12.6		43	12.1	13.1	14.2		62	13.2	14.2	15.5
16 x 8 (77.1)	Straight 22½° 45°	616	57	19.6	21.7	23.8	926	95	23.4	26.2	28.5	1232	134	26.6	29.4	32.2
			43	15.7	17.3	18.8		71	18.3	20.2	22.0		100	20.2	22.4	24.6
			29	11.6	12.7	13.5		48	12.9	14.2	15.3		67	14.1	15.6	16.6
20 x 8 (97.6)	Straight 22½° 45°	770	62	21.1	23.4	25.6	1150	102	25.1	28.2	31.1	1540	144	28.5	31.8	35.0
			47	16.8	18.5	20.1		77	19.6	21.7	23.5		108	21.7	24.2	26.4
			31	12.4	13.4	14.5		51	13.8	15.0	16.3		72	15.0	16.5	17.9
24 x 8 (118.0)	Straight 22½° 45°	920	65	22.1	24.7	27.0	1384	107	26.4	30.0	32.8	1840	151	29.9	33.6	37.5
			49	17.6	19.4	21.1		80	20.5	22.8	24.6		113	22.8	25.5	27.7
			33	12.9	14.0	15.1		54	14.3	15.7	16.9		76	15.4	17.3	18.7
30 x 8 (149.0)	Straight 22½° 45°	1160	68	23.3	26.0	28.4	1736	111	27.8	31.8	34.8	2320	157	31.4	35.5	40.4
			51	18.4	20.3	22.1		83	21.5	24.0	25.8		118	24.0	27.0	29.2
			34	13.3	14.5	15.7		56	14.8	16.4	17.6		79	16.3	18.2	19.6
36 x 8 (179.0)	Straight 22½° 45°	1404	71	24.3	27.2	29.5	2096	116	29.0	33.4	36.2	2808	164	32.8	37.3	42.2
			53	19.0	21.2	22.8		87	22.2	24.9	26.6		123	24.8	28.1	30.2
			36	13.8	15.0	16.2		58	15.3	16.9	18.2		82	16.8	18.8	20.2
16 x 10 (97.7)	Straight 22½° 45°	792	71	23.9	27.2	29.5	1190	116	28.5	33.4	36.2	1584	164	32.3	37.3	42.2
			53	19.0	21.2	22.8		87	22.2	24.9	26.6		123	24.8	28.1	30.2
			36	13.8	15.0	16.2		58	15.3	16.9	18.2		82	16.8	18.8	20.2
20 x 10 (124.0)	Straight 22½° 45°	994	75	26.0	29.6	32.0	1492	122	30.9	36.0	39.6	1988	174	35.3	40.2	46.6
			56	20.6	22.7	24.6		92	24.0	26.7	28.7		130	27.0	30.3	32.7
			38	14.6	16.0	17.3		61	16.3	18.1	19.4		87	17.9	20.3	21.7
24 x 10 (150.0)	Straight 22½° 45°	1200	80	28.0	32.0	34.2	1798	131	33.0	38.6	42.5	2400	185	38.1	43.4	50.0
			60	21.8	24.2	26.1		98	25.4	28.6	30.4		139	28.6	32.5	34.8
			40	15.3	16.9	18.1		66	17.1	19.1	20.4		93	18.8	21.5	22.8
30 x 10 (195.0)	Straight 22½° 45°	1502	86	30.2	34.6	37.4	2252	139	35.7	41.7	46.5	3004	196	41.7	47.0	54.3
			65	23.6	26.3	28.2		104	27.4	30.9	32.9		147	31.1	35.4	38.0
			43	16.3	18.2	19.3		70	18.2	20.5	21.8		98	20.1	22.8	24.5
36 x 10 (227.0)	Straight 22½° 45°	1808	87	31.3	36.0	38.5	2710	142	36.6	42.9	48.0	3616	200	43.0	49.1	55.8
			65	24.2	27.0	29.0		106	28.2	31.8	34.0		150	32.0	36.4	39.2
			44	16.6	18.5	19.7		71	18.5	20.8	22.3		100	20.5	23.3	25.0
16 x 12 (118.0)	Straight 22½° 45°	976	81	28.0	32.0	34.2	1466	131	33.0	38.6	42.5	1952	158	38.1	43.4	50.0
			61	21.8	24.2	26.1		98	25.4	28.6	30.4		138	28.6	32.5	34.8
			41	15.3	16.0	18.1		66	17.1	19.1	20.4		93	18.8	21.5	22.8
20 x 12 (150.0)	Straight 22½° 45°	1226	87	31.3	36.0	38.5	1836	142	36.6	42.9	48.0	2452	200	43.0	49.1	55.8
			65	24.2	27.0	29.0		106	28.2	31.8	34.0		150	32.0	36.4	39.2
			44	16.6	18.5	19.7		71	18.5	20.8	22.3		100	20.5	23.3	25.0
24 x 12 (181.0)	Straight 22½° 45°	1480	93	33.6	38.6	42.0	2220	153	39.4	46.3	51.5	2960	213	47.0	53.2	59.2
			70	25.8	28.9	31.0		115	29.9	34.0	36.2		160	34.2	39.2	42.1
			47	17.4	19.5	20.8		77	19.5	22.0	23.6		107	21.7	24.6	26.5
30 x 12 (228.0)	Straight 22½° 45°	1850	98	36.7	42.4	46.2	2776	163	42.8	50.0	55.8	3700	226	51.7	59.0	65.0
			74	27.8	31.1	33.6		122	32.2	36.5	39.1		169	37.0	42.3	45.8
			49	18.4	20.6	22.1		82	20.7	23.4	25.0		113	22.9	26.0	28.1
36 x 12 (275.0)	Straight 22½° 45°	2230	103	39.4	45.1	49.8	3346	172	45.7	52.2	58.7	4460	238	55.6	62.0	69.0
			77	29.4	33.0	35.7		129	33.8	38.4	41.4		178	39.0	44.7	48.7
			52	19.1	21.0	23.0		86	21.5	24.3	26.2		119	23.9	27.2	29.5

K FACTOR			
Max Cfm/Sq Ft Outlet Wall Area	7.2	4.8	3.6
Min Cfm/Sq Ft Outlet Wall Area	2.2	1.4	1.1

NOTES:

- Divergent Blow has vertical louvers straight forward in the center, with uniformly increasing angular deflection to a maximum at each end. The 45° divergence signifies an angular deflection at each end of the outlet of 45°, and similarly for 22½° divergence.
- Blow indicates distance from outlet to the point where the air stream is substantially dissipated.
- Underblow. It is not always necessary to blow the entire length of the room unless there are heat load sources at that end, equipment load, open doors, sun-glass, etc. Considering the concentration of room heat load on the basis of Btu / (hr)(sq ft), the outlet blow should cover 75% of the heat load.
- Velocity is based on effective face area.
- Static Pressure is that pressure required to produce the indicated velocities and is measured in inches of water.
- Measure ceiling height in the CLEAR only. This is the distance from the floor to the lowest ceiling beam or obstruction.
- The Minimum Ceiling Height (table) is the minimum ceiling height which will give proper operation of the outlet for the given outlet velocity, vane setting, temperature difference, blow, and cfm. The actual measured ceiling height must be equal to or greater than the selection made. Preferably the top of an outlet should be not less than twice the outlet's height below the minimum ceiling height.
- Cfm / Sq Ft Outlet Wall Area is the standard for judging total room air movement. The maximum value shown results in an air movement in the zone of occupancy of about 50 fpm. It is assumed that furniture, people, etc., obstruct 10% of the room cross-section. If the obstructions vary widely from 10% the values of the cfm / sq ft outlet wall area should be tempered accordingly.
- For applications requiring a limiting sound level – the outlet velocity is limited by the sound generated by the outlet.



INDEX

PART 2 AIR DISTRIBUTION

A

Access door

- construction

Accessories

- apparatus, see *apparatus*

- duct systems, see *duct*

Air

- apparatus, see *apparatus*

- bypass around equipment

- cleaning equipment

- control

- dampers

- duct layout

- direction

- distribution

- blow,

- direction

- drop

- duct velocity

- induction

- movement

- outlet types, see *outlets*

- rise

- spread

- temperature

- vane performance

- vane types, see *vanes*

- velocity

- table 19

- duct design, see *duct design*

- filters

- friction, ducts

- chart 5

- chart 7

- leakage

- movement,

- pressure, duct design

- terminals, see *outlets*

- velocity

- duct design

- table 7

- outlet discharge

- table 19

- table 20

- pressure

- table 8

Apartments Outlet location

Apparatus

- construction,

- table 2

- connections to masonry

- seams

- service

- design

- economic considerations

- layout

- location

- sound considerations

- equipment

- access door

- air bypass

- air cleaning

- apparatus casing

- belt guard

- cooling coils

- drains

- eliminators

- fans

- fan connections

- fan conversion loss or gain

- fan motor and drive

- heating coils

- insulation,

- layout

location
louver damper
chart 2
table 1
outdoor air louver
chart 1
marine lights,
relief damper
service
sprays
Architectural appearance,
duct design
Aspect ratio, duct design
chart 3
chart 4,
chart 5

B

Bank outlet location,
Belt guard
Blow,

C

Ceiling diffuser
application
approach
blow
location
noise limitations
table 20

obstructions
pressure drop
types
diffuser
pan
perforated ceiling and panels
return grille,

Ceiling return outlet

Coils

cooling, see *cooling coils*
heating, see *heating coils*

Condensation on duct

Cooling coils

service

D

Dampers

louver,
chart 2
table 1
construction
relief,
construction

Department store outlet location

Diffuser

application
ceiling
location

Drop,

air from outlet

Duct

access doors
air pressure

air velocity
table 7
classification of systems
condensation
table 4
table 5
construction, see *duct construction*
design, see *duct design*
fire dampers
fittings, type
table 3
layout
pressure
velocity
table
velocity pressure
table 8

Duct construction

high pressure
table 15
table 16
table 17
low pressure
tables 14, 15, 16
weight of duct material
table 18

Duct design

accessories
air control
air leakage
air quantity
air velocity

table 7	equivalent round	chart 9
architectural appearance	diameter	table 9
aspect ratios	table 6	velocity
chart 3	fan conversion loss or gain	table 7
chart 4	fittings	velocity pressure
chart 5	table 3	table 8
condensation	flexible metal conduit	velocity reduction method
table 4	chart 8	weights of duct materials
table 5	friction chart	table 18
construction (high pressure)	chart 7	Duct heat gain or loss
table 15	friction rate	chart 3
table 16	chart 5	chart 14
table 17	chart 7	table 5
construction (low pressure)	heat gain or loss	Duct layout
tables 14, 15, 16	chart 3	access doors
duct diameter	chart 14	air control
table 6	table 5	condensation
economics	high altitude	table 4
chart 3	chart 15	table 5
chart 4	high velocity duct systems	considerations
chart 5	static regain	economics
elbow friction, rectangular	low velocity duct systems	elbows
table 10	equal friction	fire dampers
table 12	static regain	obstructions, pressure loss
elbow friction, round	velocity reduction pressure	table 10
chart 9	reducing duct space	reducing duct size
table 9	static regain, high velocity	take-off s
table 11	chart 12	transformations
elbow vane location	chart 13	vaned elbows
chart 6	static regain, low velocity	chart 6
equal friction method	charts 10, 11	
table 7	take-off	
table 13	take-off friction, round	

E

Economics

- apparatus design
- duct design
- chart 3
- chart 4
- chart 5

Ejector outlet

Elbows

- pressure loss, rectangular
- table 10
- table 12
- pressure loss, round
- chart 9
- table 9
- table 11
- types,
- vane spacing
- chart 6

Eliminators

Equal friction method sizing ducts

- table 7
- table 13

Equivalent duct diameter

- table 6

F

Fan

- connections
- conversion loss or gains

motor and drive

Filters, see air

Fire dampers

- construction
- rectangular louver
- rectangular pivot
- round pivot

Fittings

- air control
- elbows,
- obstructions
- take-off
- transformations
- types and classes
- table 3

Flexible metal conduit

- chart 8

Floor outlets

- application
- location

Floor return grille

Friction chart, duct design

- chart 7

Friction rate, duct design

- chart 5
- chart 7

G

Grille

- adjustable bar
- application
- location

perforated

return, see *return grille*

H

Heat gain or loss

- chart 3
- chart 14
- table 5

Heating coils

- preheat
- reheat
- service
- tempering

High altitude duct design

- chart 15

High velocity duct design

Hotel outlet location

I

Induction outlet

- application
- location

L

Louver damper

- construction
- design
- chart 2
- table 11

Low velocity duct design

M

Metal conduit, flexible

chart 8

O

Obstructions, duct design

pressure loss

table 10

Office building outlet locations

Outdoor air louver

construction

design

Outlet

adjustable bar grille

air movement

air velocity

table 19

table 20

applications

blow

ceiling

ceiling diffusers

ceiling return

drop

ejector

fixed bar grille

floor

floor return

induction

location

noise limitation

table 20

obstructions

pan

perforated ceiling and panels

perforated grille

ratings

table 21

return grille

selection

table 21

slotted

temperature differential

vanes

wall

wall return

window

P

Pan outlet

Perforated ceiling and panels

Perforated grille outlet

Preheat coils

Pressure, duct sizing

R

Reheat coils

Relief dampers

construction

Restaurant outlet locations

Return grille

ceiling

floor

location

velocity

wall

Rise, air from outlet

Room air distribution, see *air distribution*

S

Slotted outlet

Sound level

apparatus

duct design

table 7

outlets

table 20

Space limitation, duct design

Sprays

service

Static regain sizing ducts

high velocity

chart 12

chart 13

low velocity

chart 10, 11

Store outlet location

T

Take-off

duct layout

pressure drop, round, 2-38

chart 9
table 9
Temperature, outlet discharge,
Tempering coils
Theater outlet locations
Transformations, duct layout, 2-20

V

Vanes
converging

diverging
performance,
spacing
chart 6
straight
Velocity, duct design
table 7

Velocity pressure
table 8

Velocity reduction method, sizing
ducts

W

Wall outlets
Wall return grille
Weight of duct metal
table 18
Window outlets



FIGURE

PART 2 AIR DISTRIBUTION

- Fig. 1 – Typical Central Station Equipment
- Fig. 2 – Out door Air Louver and Screen
- Fig. 3 – Gooseneck Outside Air Intake
- Fig. 4 – Louver Damper Arrangements
- Fig. 5 – Relief Damper
- Fig. 6 – Single Fan Inlet and Discharge Connections
- Fig. 7 – Multiple Fan Unit Discharge Connections
- Fig. 8 – Flexible Connection
- Fig. 9 – Two-Piece Belt Guard
- Fig. 10 – Apparatus Casing Seams
- Fig. 11 – Apparatus Casting
- Fig. 12 – Connection to Masonry Curb
- Fig. 13 - Connection to Masonry Wall
- Fig. 14 – Low Dewpoint Masonry Curb Connections
- Fig. 15 – Low Dewpoint Masonry Curb Connections
- Fig. 16 – Sealing Standing Seams
- Fig. 17 – Sealing Pipe Connections
- Fig. 18 – Access Doors
- Fig. 19 – Duct Transformation
- Fig. 20 – Rectangular Duct Transformation to Avoid Obstruction
- Fig. 21 – Round Duct Transformation to Avoid Obstruction
- Fig. 22 – Duct Transformation With Equipment in the Duct
- Fig. 23 – Easements Covering Obstruction

Fig. 24 – Easements Covering Irregular Shapes

Fig. 25 – Duct Transformed for Easements

Fig. 26 – Full Radius Rectangular Elbow

Fig. 27 – Short Radius Vaned Elbow

Fig. 28 – Rectangular Elbow Vane Location

Fig. 29 - Rectangular Elbow With No Throat Radius

Fig. 30 – Vaned Square Elbow

Fig. 31 - 90° Smooth Elbow

Fig. 32 - 90° 3-piece Elbow

Fig. 33 - 90° 5-piece Elbow

Fig. 34 - 45° 3-Smooth Elbow

Fig. 35 - 45° 3-piece Elbow

Fig. 36 – Typical Takes-offs

Fig. 37 – Outlet Collar

Fig. 38 - 90° Tee

Fig. 39 - 90° Conical Tee

Fig. 40 – Crosses

Fig. 41 – Reducing Duct Size at Take- off

Fig. 42 - Reducing Duct Size After Take - off

Fig. 43 – Rectangular Pivot Fire Damper

Fig. 44 – Rectangular Pivot Fire Damper

Fig. 45 – Round Pivot Fire Damper

Fig. 46 – Guide for Measuring Duct Lengths

Fig. 47 – Duct Layout for Low Velocity System (Example 4 and 5)

Fig. 48 – Duct Sizing Calculation Form

Fig. 49 – Comparison of Duct Sizing Methods

Fig. 50 – Spacing of Fittings in Duct Run

Fig. 51– Spacing of Fittings When Using 90° Conical Tee

Fig. 52 – High Velocity Header and Branches

Fig. 53 – Branch Duct for Example 6

Fig. 54 – High Velocity Branch Sizing Calculations

Fig. 55 – High Velocity Duct System-Header Static Regain Method Sizing

Fig. 56 – High Velocity Header Sizing Calculations

Fig. 57 – Duct Heat Gain and Air Leakage

Fig. 58 – Joints and Seams For Low Pressure System

Fig. 59 – Joint For High Pressure System

Fig. 60 – Round Duct Joints and Seams

Fig. 61 – Joints and Seam For Spira-pipe

Fig. 62 – Desirable Air Direction

Fig. 63 - Effect of Induction

Fig. 64 - Spread with Straight Vanes

Fig. 65 - Spread with Converging Vanes

Fig. 66 - Spread with Diverging Vanes

Fig. 67 - Spread with Straight Vanes Set at An Angle

Fig. 68 - Outlet Located in Duct

Fig. 69 - Collar for Outlets

Fig. 70 - Air Stream Patterns for Various Temperature Differentials

Fig. 71 - Internal Induction Ceiling Diffuser

Fig. 72 - Downdraft from Cold Window

Fig. 73 - Discharge Air Offsetting Window Downdraft

Fig. 74 – Wall Outlet in Room With Ceiling Obstruction

Fig. 75 – Wall Outlet Near Floor

Fig. 76 – Corridor Air Supply

Fig. 77 – Corridor Air Supply with Direct Radiator

Fig. 78 – Duct Above Window, Blowing Toward Corridor

Fig. 79 – Window Outlet

Fig. 80 – Air Distribution with High Ceiling

Fig. 81 – Mezzanine Air Distribution

Fig. 82 – Restaurant Air Distribution

Fig. 83 – Air Distribution from Rear of Store

Fig. 84 – Air Distribution from Over the Door

Fig. 85 – Air Distribution from Each End of Store

Fig. 86 – Air Distribution from Center of Store

Fig. 87 – Air Distribution from Sidewall Outlets

Fig. 88 – Air Distribution from Ceiling Diffusers

Fig. 89 – Air Distribution from Small Theatres

Fig. 90 – Air Distribution from for Large Theatres with Balcony

Fig. 91 – Overhead Air Distribution

Fig. 92 – Velocity Fall-off per Distance from Grille

Fig. 93 – Wall Outlet On Which Ratings Are Based



TABLE

PART 2 AIR DISTRIBUTION

TABLE 1 – LOUVER DAMPERS

TABLE 2 – SUPPLEMENTAL REINFORCING FOR APPARATUS CASING

TABLE 3 – DUCT FITTING CLASSES

TABLE 4 – MAXIMUM DIFFERENCE BETWEEN SUPPLY AIR TEMPERATURE AND ROOM DEWPOINT WITHOUT CONDENSING MOISTURE ON DUCT (F)

TABLE 5 – DUCT HEAT TRANSMISSION COEFFICIENTS

TABLE 6 – CIRCULAR EQUIVALENT DIAMETER, * EQUIVALENT AREA AND DUCT CLASS OF RECTANGULAR DUCTS FOR EQUAL FRICTION.

TABLE 6 – CIRCULAR EQUIVALENT DIAMETER, * EQUIVALENT AREA AND DUCT CLASS OF RECTANGULAR DUCTS FOR EQUAL FRICTION. (Cont.)

TABLE 6 – CIRCULAR EQUIVALENT DIAMETER, * EQUIVALENT AREA AND DUCT CLASS OF RECTANGULAR DUCTS FOR EQUAL FRICTION. (Cont.)

TABLE 7 – RECOMMENDED MAXIMUM DUCT VELOCITIES FOR LOW VELOCITY SYSTEMS (FPM)

TABLE 8 – VELOCITY PRESSURES

TABLE 9 – FRICTION OF ROUND DUCT SYSTEM ELEMENTS

TABLE 10 – FRICTION OF RECTANGULAR DUCT SYSTEM ELEMENTS

TABLE 10 – FRICTION OF RECTANGULAR DUCT SYSTEM ELEMENTS (Contd)

TABLE 11 – FRICTION OF ROUND ELBOWS

TABLE 12 – FRICTION OF RECTANGULAR ELBOWS

TABLE 12 – FRICTION OF RECTANGULAR ELBOWS (CONT.)

TABLE 13 – PRECENT SECTION AREA IN BRANCHES FOR MAINTAINING EQUAL FRICTION

TABLE 14 – RECOMMENDED CONSTRUCTION FOR RECTANGULAR SHEET METAL DUCTS

TABLE 15 – RECOMMENDED CONSTRUCTION FOR RECTANGULAR SHEET METAL DUCT

TABLE 16 – MATERIAL GAGE FOR SPIRA-PIPE DUCT

TABLE 17 – RECOMMENDED CONSTRUCTION FOR RECTANGULAR SHEET METAL DUCTS

TABLE 18 – WEIGHT OF DUCT MATERIAL

TABLE 19 – OCCUPIED ZONE ROOM AIR VELOCITIES

TABLE 20 – RECOMMENDED OUTLET VELOCITIES

TABLE 21 – WALL OUTLET RATINGS, FOR COOLING ONLY

TABLE 21 – WALL OUTLET RATINGS, FOR COOLING ONLY (Cont.)

TABLE 21 – WALL OUTLET RATINGS, FOR COOLING ONLY (Cont.)

TABLE 21 – WALL OUTLET RATINGS, FOR COOLING ONLY (Cont.)

TABLE 21 – WALL OUTLET RATINGS, FOR COOLING ONLY (Cont.)

TABLE 21 – WALL OUTLET RATINGS, FOR COOLING ONLY (Cont.)

TABLE 21 – WALL OUTLET RATINGS, FOR COOLING ONLY (Cont.)



CHART

PART 2 AIR DISTRIBUTION

- CHART 1 – LOUVER PRESSURE DROP
- CHART 2 – LOUVER DAMPER LEAKAGE
- CHART 3 – DUCT HEAT GAIN VS ASPECT RATIO
- CHART 4 – INSTALLED COST VS ASPECT RATIO
- CHART 5 – OPERATING COST VS ASPECT RATIO
- CHART 6 – VANE LOCATION FOR RECTANGULAR ELBOWS
- CHART 7 – FRICTION LOSS FOR ROUND DUCT
- CHART 8 – PRESSURE DROP THRU FLEXIBLE CONDUIT
- CHART 9 – LOSSES FOR ROUND FITTINGS
- CHART 10 – L/Q RATIO
- CHART 11 – LOW VELOCITY STATIC REGAIN
- CHART 12 – BRANCH HIGH VELOCITY STATIC REGAIN
- CHART 13 – HEADER HIGH VELOCITY STATIC REGAIN
- CHART 14 – DUCT HEAT GAIN OR LOSS
- CHART 15 – AIR DENSITY CORRECTION FACTORS